



PETITION FOR A SPECIAL PRIVILEGE

ccl-246 (7/15)

SP 2743
CCF 160487

- New application \$250.00 Fee
- Amendment to add items to Special Privilege # 2694 (\$125.00 Fee)
- Amendment to remove items from Special Privilege # _____ (No fee)
- Amendment for change of ownership for Special Privilege # _____ (No fee)

- File petition with the Department of Public Works, Attention: Special Privileges, 841 North Broadway, Room 919, Milwaukee, WI 53202.
- Fee must be submitted with petition. Checks should be made payable to the City of Milwaukee.
- Questions? Call 414-286-2454

To the Honorable, The Common Council of the City of Milwaukee:

The Licensee Florida Lofts LLC
(Name of Individual, Partners, Corporation or LLC)

being the owners of the following property known by street address as 408 W Florida St, 53204
(Street Address and Zip Code)

in the 12th Aldermanic District respectfully petition the Common Council of the City of Milwaukee according to the provisions of Section 66.0425 of the Wisconsin Statutes, that the following privilege be granted:

Description of Special Privilege: Amendment to CCF 150294 for addition of moveable planters

Of which a plan or sketch is herewith submitted. Petitioner agrees to comply with all laws and all ordinances of the City of Milwaukee, to abide by any order or resolution of the Common Council affecting this privilege, to be primarily liable for damages to person or property by reason of the granting of such privilege, pay annual compensation as provided by law in the sum to be fixed by the proper city officers, and to file and keep current throughout the existence of the privilege, a certificate of insurance indicating applicant holds a public liability policy in at least the sums of \$25,000.00/\$50,000.00 bodily injury, and \$10,000.00 property damage, insuring the city against any liability that might arise by reason of the privilege.

Petitioner further agrees to remove said privilege whenever public necessity so requires when so ordered upon resolution adopted by the Common Council or other legislative body.

Should this special privilege be discontinued for any reason whatsoever, petitioner agrees to remove all construction work executed pursuant to this special privilege, to restore to its former condition and to the approval of the Commissioner of Public Works, any curb, pavement, or other public improvement which was removed, changed or disturbed by reason of the granting of this special privilege. Petitioner further agrees not to contest the validity of Section 66.0425 of the Wisconsin Statutes, or the legality of this special privilege in any way.

Name (Please Print): Dustin Sydorowicz (Agent for Florida Lofts LLC)
(Individual, Partner, or Agent if corporation or LLC as shown above)

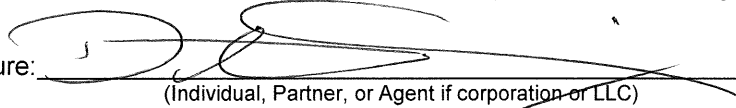
Signature:  Date: 6/14/16
(Individual, Partner, or Agent if corporation or LLC)

Corporation or LLC Name: Florida Lofts LLC
(If applicable, as shown above)

Mailing Address (If different than property address above): _____

(OVER)

City: _____ State: _____ Zip: _____

Telephone: (414) 727-2749 E-Mail: dsydorowicz@sg-re.com

Architect/Engineer/Contractor (If Applicable)

Name: NA

Address: _____

City: _____ State: _____ Zip: _____

Telephone: _____ E-Mail: _____

IMPORTANT NOTICE FOR CUSTOMERS PAYING BY CHECK

When you provide a check as payment, you authorize us either to use information from your check to make a one-time electronic fund transfer from your account or to process the payment as a check transaction.



June 14, 2016

RE: 408 W. Florida St Tree Planter
Ref. #2694

To: Whom it May Concern

I'm writing you today obtain a permit allowing for Florida Lofts LLC to have 4 tree planters place on the sidewalk in front of our property located at: 408 W. Florida St., Milwaukee, WI 53204.

Enclosed, you will find a: Petition for a Special Privilege Application, Spec. Sheet for Planters, Location Rendering, Picture of the Planters, Planned Tree Species Info and a check for \$125.00.

If you have any questions or require additional information, please feel free to contact me directly at 414-727-2749 or by email at dsydorowicz@sg-re.com.

Sincerely,

A handwritten signature in black ink, appearing to read "Dustin Sydorowicz", written over a horizontal line.

Dustin Sydorowicz
Property Manager
Brix Apartment Lofts

DAWN

Enterprises

Specification Sheet

PC48S: 48" x 48" x 36" Square Concrete Planter

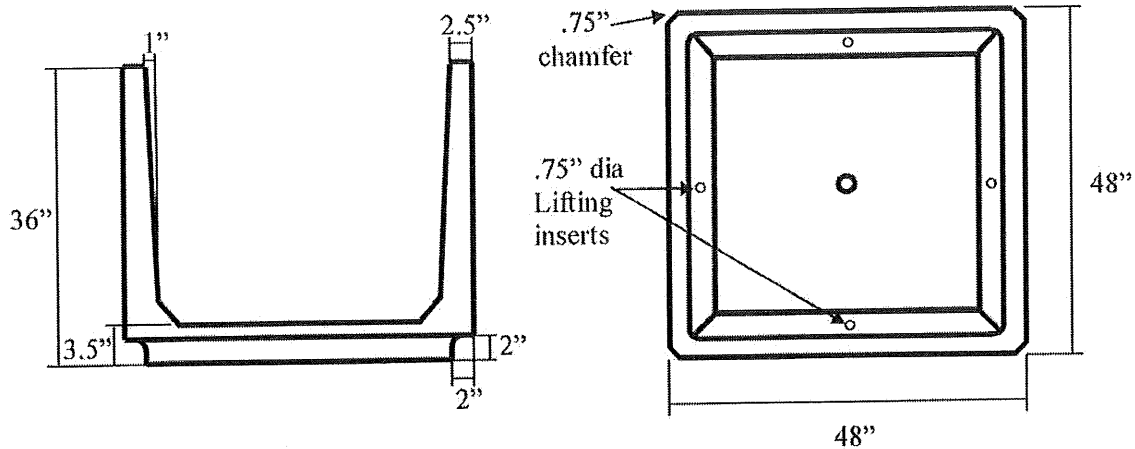

Specifications:

- Dimensions: 48" x 48" x 36" with 2.5" wall thickness at top.
- Weight: 2250 lbs
- Materials: 3/8" steel rebar, Type III Portland cement conforming to ASTM C150. All aggregate conforming to ASTM C33. All Steel Rebar conforming to ASTM - A 615. Due to the natural air entraining properties of Portland Type III cement, additional air entraining agents are not required. Air void content naturally occurring in a Type III Portland Cement mixture conforms to ASTM C457.
- Stress Load: 4000 PSI at 28 days
- Color/Finish: Please reference our color/finish chart for standard options.
- Warranty: One year warranty against manufacturer's defects.

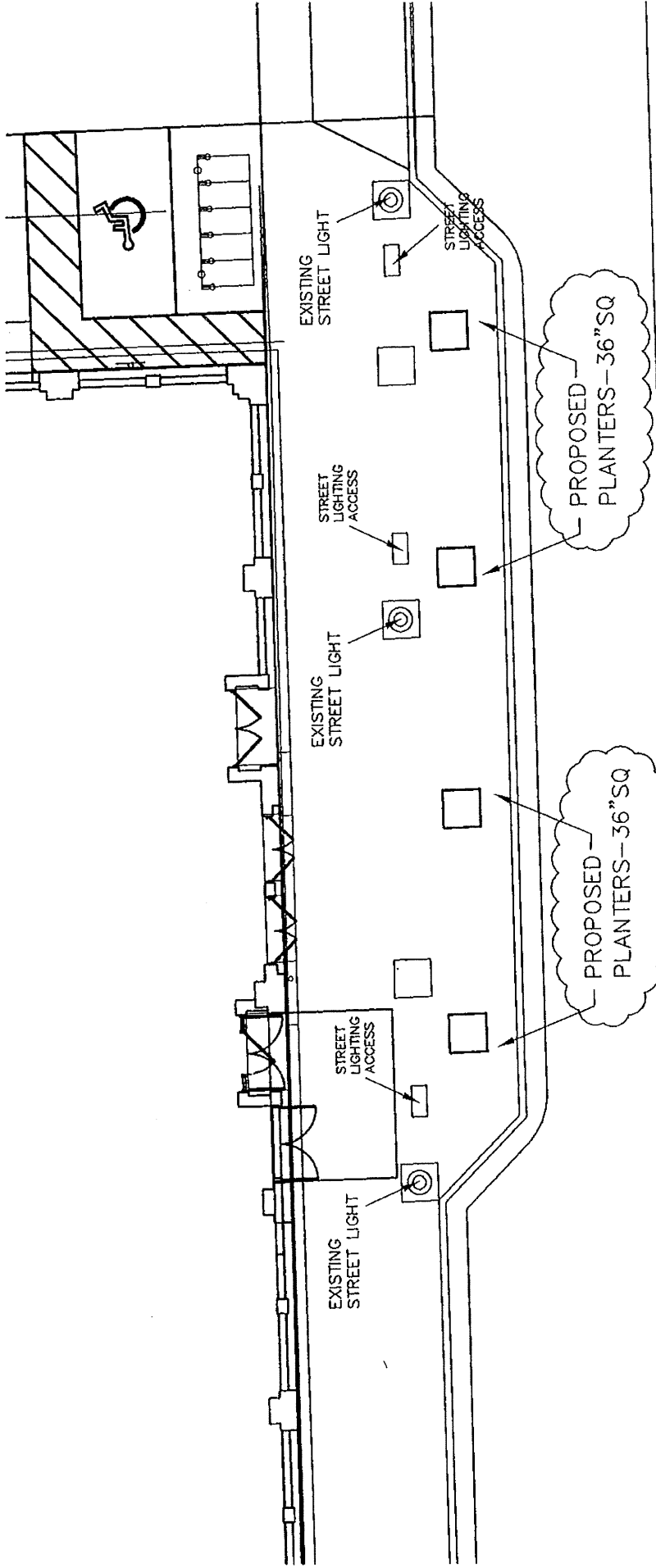

W. FLORIDA STREET

Enterprises
GoDawn.com

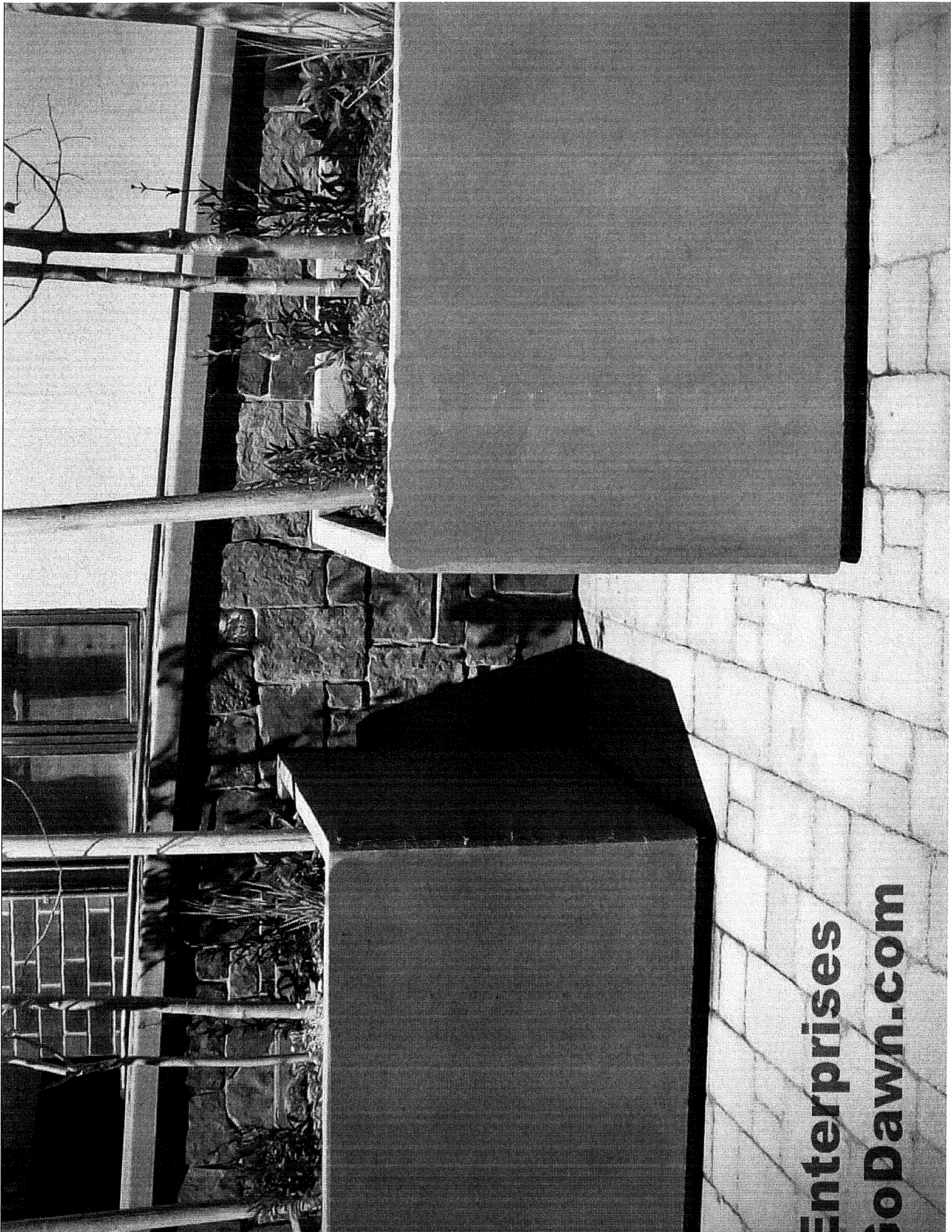

Ivory Silk Tree Lilac

Syringa reticulata 'Ivory Silk'

- ∞ Graceful, hardy, vigorous, deciduous tree with rounded crown.
- ∞ Clusters of creamy white flowers brighten the late spring garden.
- ∞ Excellent specimen, accent or in groups. Grows 20'T x 15'W.
- ∞ Full sun for best flowering.

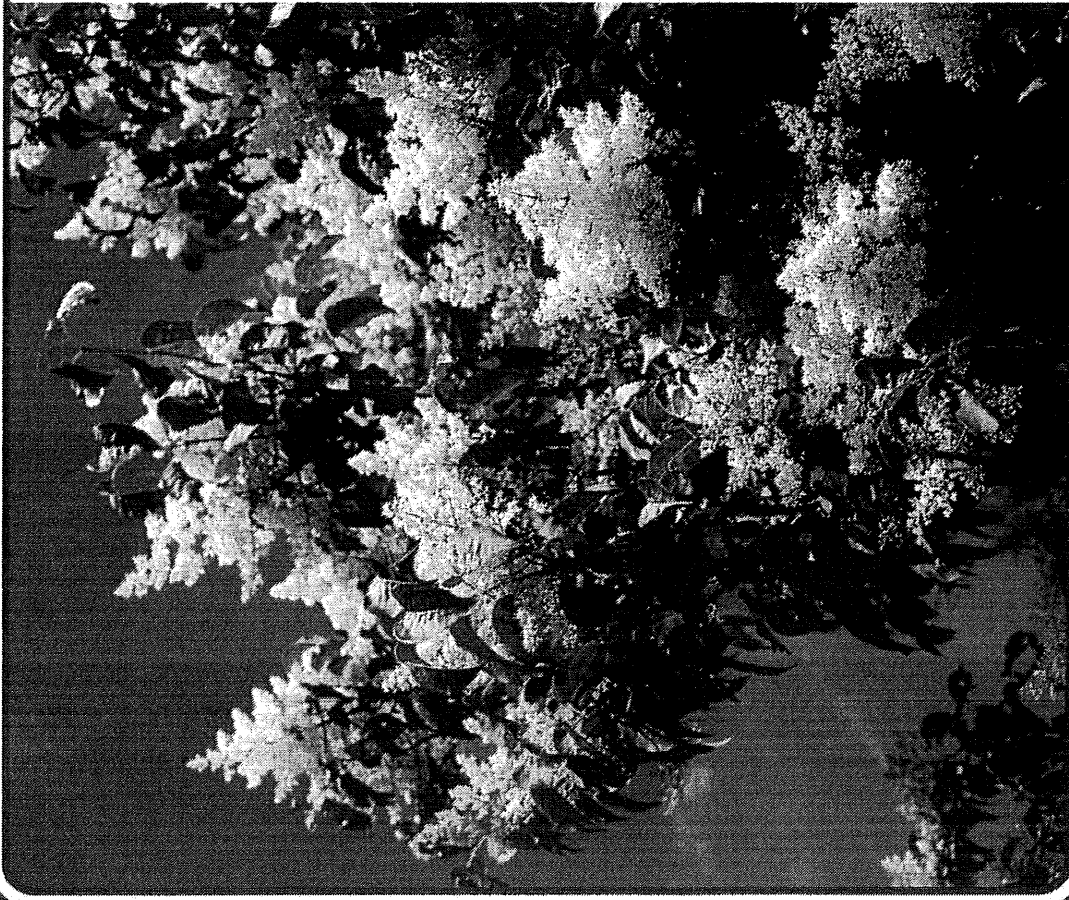

87553

62628