



# Certificate of Appropriateness

Milwaukee Historic Preservation Commission/841 N Broadway/Milwaukee, WI 53202/phone 414-286-5712

**Property  
Description of  
work**

**2128 E Woodstock Pl, North Point South HD**

Remove current backyard deck rail and spindles and replace with pressure treated lumber to be stained as the same color as the deck after the wood is dry and weathered

**Date issued** 4/24/23

In accordance with the provisions of Section 320-21 (11) and (12) of the Milwaukee Code of Ordinances, the Milwaukee Historic Preservation Commission has issued a certificate of appropriateness for the work listed above. The work was found to be consistent with preservation guidelines. The following conditions apply to this certificate of appropriateness:

All finish wood must be smooth and free of knots and must be painted or treated with an opaque stain upon completion. Note: when new, bare wood is left exposed to the exterior elements for a period of only a week or two, the life of the paint job subsequently applied to it will be decreased. The use of a decay-resistant wood for exterior finish applications is required for porch areas.

All work must be done in a craftsman-like manner, and must be completed within one year of the date this certificate was issued. Staff must approve any changes or additions to this certificate before work begins. Work that is not completed in accordance with this certificate may be subject to correction orders or citations. If you require technical assistance, please contact Historic Preservation staff as follows: Phone: (414) 286-5722 E-mail: [hpc@milwaukee.gov](mailto:hpc@milwaukee.gov).

If permits are required, you are responsible for obtaining them from the Milwaukee Development Center. If you have questions about permit requirements, please consult the Development Center's web site, [www.milwaukee.gov/lms](http://www.milwaukee.gov/lms), or call (414) 286-8210.

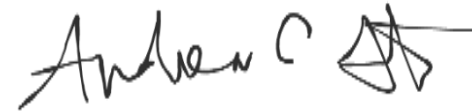
A handwritten signature in black ink, appearing to read "Andrew C." followed by a stylized monogram or initials.

City of Milwaukee Historic Preservation

Copies to: Development Center, Alderperson



Existing balusters and rails to be removed

# Porches



## Basic Railing and Newel Post Design

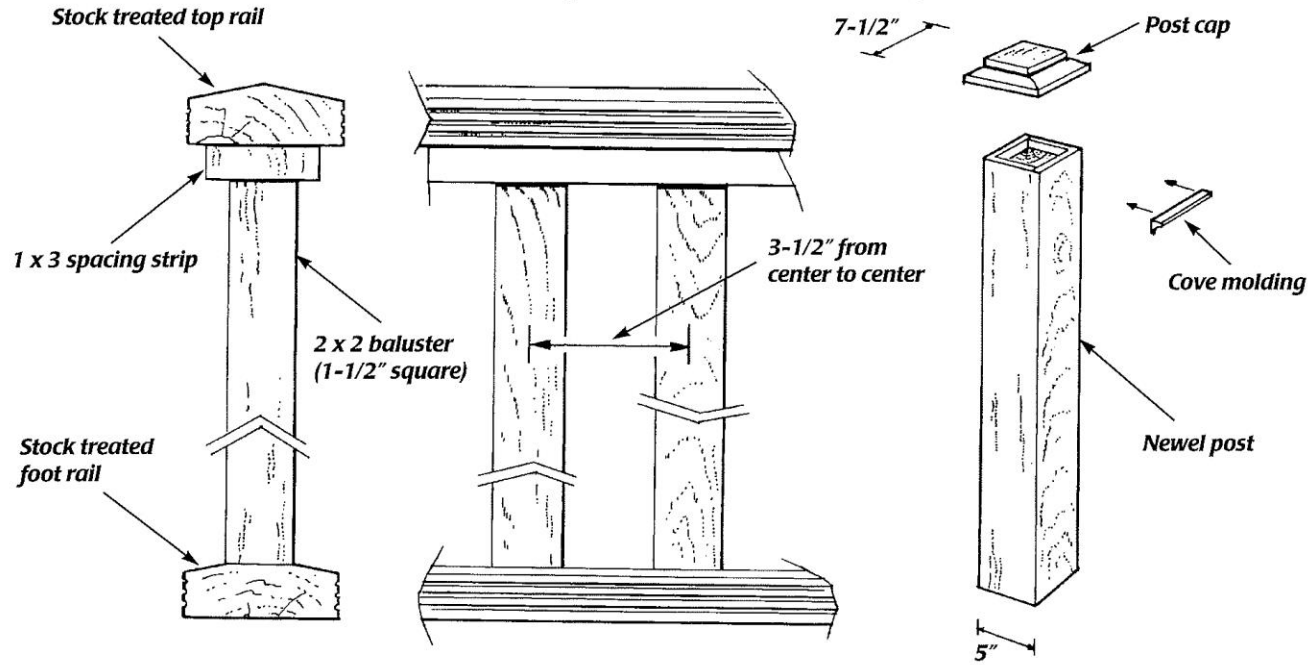

*The number of historic handrail and newel post designs is literally endless. The above designs are appropriate for many houses built before 1940 and would be approved by the Historic Preservation Commission for most homes.*

53

New baluster and rail design