

EXHIBIT A

File No. 021760

ZND/CC

PARK PLACE

DETAILED PLANNED DEVELOPMENT (DPD)

PROPOSED STAGE XXIV

EXHIBIT "A"

INTRODUCTION:

The General Planned Development, known as Park Place, was originally approved as a 140-acre Type I General Plan in February 1981, and subsequently amended with the 135-acre expansion, to provide for the staged deferred development of approximately 275 acres of land in the northwest side of Milwaukee. The proposed General Plan for Park Place consists of an integration of commercial developments within a total and distinct environment. The diverse blend of activities will be unified through use of lakes, open green spaces, landscaping and high quality architecture in a campus-like atmosphere.

The proposed Stage XXIV development is for an approximately 90,000 square foot one-story office building, located on an approximately 14.75 acre parcel within Area "C" of the General Planned Development (GPD) for Park Place. Liberty Property Trust (Liberty), as both the Owner and developer of the remaining land within Area "A" and "C" of Park Place, is developing the office building as the new corporate headquarters facility for eFunds, who is relocating from Glendale.

BOUNDARIES:

The exact boundaries for the portion of Area "C" in Park Place proposed to be rezoned from the General Planned Development (GPD) to a Detailed Planned Development (DPD) are described in detail on the legal description. The overall existing Park Place legal description and Plat of Survey are on file with the City. The area included in the Detailed Plan is located immediately north of W. Liberty Drive, directly east of the northern portion of Area "B" which contains the Hilton Hotel and south of the W. Calumet Road residential zoning that lies directly north of Area "C" of Park Place as shown on the Site Plan. A Certified Survey Map is currently being prepared for this site.

HISTORY OF DEVELOPMENT:

The history of development of Park Place began with the initial General Planned Development (GPD) for a 140-acre tract of land purchased by Trammell Crow Company in 1980, which was bounded by North 107th Street to the east, West Good Hope Road to the south and U.S. 41 and U.S. 45 to the west. Trammell Crow subsequently expanded the project to 275 acres with the purchase of a 135-acre tract of land at the southwest corner of North 107th Street and West Bradley Road. During the last ten years Park Place has undergone a transfer of ownership with many buildings being bought by Real Estate Investment Trusts (REITs) and a significant portion of the northeast portion of Park Place is owned and being developed by M&I Data for their own needs. More recently, Liberty

Property Trust, a large national REIT, has purchased ten buildings in Park Place and acquired the 75 acre balance of the land within Areas "A", "B" and "C" along West Good Hope Road around the existing 7.5 acre man-made lake. Liberty, through and Out-of-Program Agreement with the City of Milwaukee, completed the construction of underground utilities and paving of this public ring road around the north and east sides of the lake, and has completing the master grading of the site with an approved storm water management plan, to permit the phased development of this land. This land is called "Liberty at Park Place" to allow Liberty to establish their own identity within Park Place. The grading and implementation of an approved master storm water management plan to serve Areas "A" and "C" was completed last year by Liberty.

TOPOGRAPHY:

The topography for the site, that was pre-graded with the Master Grading done by Liberty, slopes up to the W. Calumet Road ridge to the north and slopes gradually down from east to west into a large man-made retention pond designed to serve the phased development of this land. The final grading plan will coordinate the finished grades with the existing grades and proposed finish grades for W. Liberty Drive.

ACCESS:

Access to the site from West Good Hope Road would be via the North 110th Street entrance/exit ramps for westbound traffic and from an entrance "trumpet" ramp for eastbound traffic. Access to the site from North 107th Street would be along West Park Place, which runs along the southern and western property boundaries of Park Place. West Park Place is a four-lane boulevard that connects the primary access points from West Good Hope Road and North 107th Street to W. Liberty Drive, the new ring road completed last year that connects from W. Park Place to the east in Area "A" that was designed to serve the vacant land to the north and east of the large man-made lake and reconnects to W. Park Place to the west in Area "B".

UTILITIES:

The utility mains in Liberty Parkway were designed and sized to service the future internal developments within Area "C". The civil design utilizes existing laterals within the W. Liberty Drive to the south, with sanitary sewer and water main connections extended into the south side of the building. The parking lot storm sewer design will remain internal to the development (given the parking areas are north of the building) and the will collect surface drainage and connect into the new storm water detention pond with sedimentation basin located at the west end of the development. The roof drainage will connect into the new storm sewer within W. Liberty Drive. The master storm water management plans for Area "C" have been previously approved by the City of Milwaukee Department of Public Works and implemented by Liberty to permit the phased development of the vacant land.

STANDARDS:

The General Planned Development Standards shown on Exhibit "D" outlines the Permitted Uses, Minimum Building setbacks and Spacing, Required Off-Street Parking, Signage Standards, Miscellaneous Design Standards along with Exhibit D-1 Area Schedule and Map. The area Schedule and Map break down this site into seven sub-areas labeled "A" to "G". Within each sub-area, the schedule identifies the total building area, land area, parking area, road/drive area, total open land area, maximum building height and permitted uses.

PROPOSED STAGE XXIV:

The proposed Detailed Planned Development (DPD) will permit Liberty to develop an approximate 90,000 square foot one-story office building located on an approximate 14.75 acre site at the northwest corner of Area "C" of the General Planned Development (GPD), with surface parking provided for approximately 450 cars. The one-story building "footprint" requested by eFunds, consists of two large flanking "wings" with curved "elbows" joined by a central curved "hub" that serve to visually reduce the length of the office building from the road. The building has been sited in a manner that fronts W. Liberty Drive and serves to screen the parking from the public way. The curved building elements relate to the existing three-story Liberty I office building that is Liberty's "flagship" at the entrance into Liberty at Park Place. The architecture for the building features the use of an articulated masonry and glass facade with stepped parapets to screen the rooftop mechanical units at the building "elbows" and central "hub". The building consists of two-tone colored masonry columns and canopies with granite accents; recessed dark bronze aluminum framed green tinted glass ribbon windows with masonry or spandrel glass knee walls. The building structural bays are expressed to create a rhythm with the use of both vertical and horizontal offsets to further breakdown the visual scale and length of the building. The building has been designed to provide for flexibility for Liberty and eFunds through the use of a central major entrance and flanking minor entrances with restroom cores. While the initial need of eFunds is for 60,000 square feet of office space, they have required up to 50% expansion be accommodated within a single level building.

The parking lot has also been broken down through the use of multiple landscaped islands. The 100-foot landscape hillside buffer to the north will provide both physical and visual separation from the W. Calumet Road residential neighbors to the north. The dumpster will be enclosed and further screening provided with landscaping

More specifically this Detailed Plan proposes the following impact on Area "C" of the General Planned Development:

PARK PLACE AREA SCHEDULE:

Area C	Proposed Stage XXIV Areas:	
Total Building Floor Area	89,178 s.f.	(13.9%)
Total Building Coverage	89,178 s.f.	
Land Area	640,475 s.f. (To be confirmed with a C.S.M.)	
Paved Area	162,881 s.f.	(25.4%)
Total Open Land Area	388,418 s.f.	(60.7%)

CONCLUSION:

In conclusion, the Stage XXIV Detailed Planned Development is intended to meet the needs of Liberty Property Trust, to expand upon the existing high quality and unified concept of the original planned development. It is our desire to continue the creation and expansion of the Park Place project as a project of the highest quality standards in the City of Milwaukee, in a manner that is mutually beneficial to the public and private sectors of the community. It is with these intentions that the Detailed Planned Development is respectfully submitted for approval to the City Plan Commission and Common Council.

Stephen Perry Smith, AIA
 Liberty Property Trust Owner's Representative

EXHIBIT B

Park Place

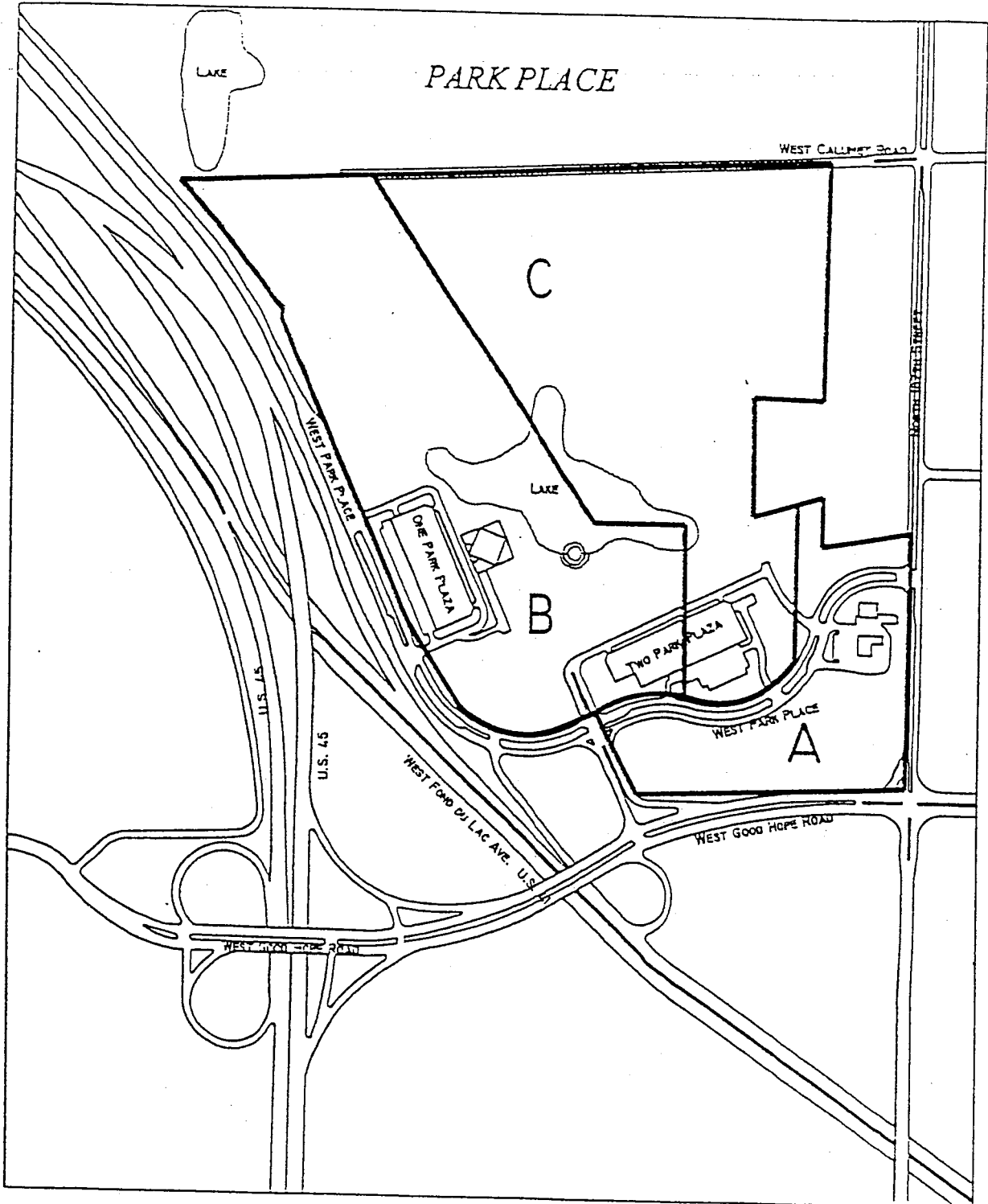

Exhibit D**Park Place General Planned Development Standards****Permitted Uses.**

- A. Administrative, business and professional offices
- B. Governmental and public utility offices
- C. Banks, savings and loan offices, finance companies, and title company offices
- D. Travel agencies¹
- E. Telephone answering service, delivery service, copying service¹
- F. Type "A" restaurants
- G. Commercial hotel or motel
- H. Public buildings intended for general public utilization including meeting rooms, community centers and libraries
- I. Medical or dental clinic¹
- J. Private non-commercial club or lodge¹
- K. Barber shop, beauty shop¹
- L. Medical or dental laboratory¹
- M. Privately operated indoor and/or outdoor recreation facilities including racquetball clubs, exercise clubs, movie theaters, tennis courts, putting greens and musical amphitheaters subject to detail plan approval.
- N. Data processing centers, consumer credit agencies, credit reporting and collecting, advertising service
- O. Laboratories and facilities for research
- P. Bar or tavern^{1,2}

¹ Permitted only where said use would be located within an office building or within a hotel or motel structure. Notwithstanding the foregoing, this restriction shall not apply to Area A.

² Permitted within a restaurant.

Q. Accessory uses normally associated with any of the listed Permitted Uses (A-P above)

R. Daycare facilities

S. Indoor storage for wholesale trans-shipment, future use or safekeeping of anything except coal in yards, explosives in bulk, gas in excess of 1,000 cubic feet, junk, garbage, or refuse, petroleum above ground or in excess of 1,000 gallons, rags or scrap paper, rawhides or skins.

T. Specialty schools

U. Business Service establishments primarily engaged in rendering services to business on a fee or contract basis including but not limited to advertising services, business equipment and furniture sales or rental or protective services, computer equipment sales, electronic communication sales, employment agencies, photocopy center, commercial photography studio or mailing service.

V. Personal Service establishments primarily engaged in providing services that are of a recurring and personal nature to individuals and families including but not limited to a barber shop, beauty salon, shoe repair shop, seamstress, tailor, and tanning parlor.

W. Dry Cleaning establishment that launders or dry cleans articles dropped off on the premise directly by the customer or where articles are dropped off sorted and picked-up and where cleaning may be done on-site.

Minimum Building Setbacks and Spacing

A. Where the site's exterior boundaries abut public right-of-way, the minimum building setback from property line varies from 70 feet along North 107th Street, 50 feet along West Good Hope Road and West Bradley Road, to 25 feet along W. Park Place and the interior roads (if public).

B. Where the site's exterior boundaries abut lands zoned for residential use, the minimum building setback shall be 50 feet for any building, except where the property line abuts the New Life Community Church property (12228 W. Park Place) and indents 14.65' for 247.5'; the setback shall be reduced to 35 feet. The use of earth berms, the placement of deciduous/coniferous trees and shrubs and other possible landscape techniques will be used to provide high level visual screening within the setback area.

C. A 100'-0" landscape buffer strip to be provided along the south side of West Calumet Road across from existing residential properties which will incorporate the use of earth berms and/or gradient changes and the placement of coniferous

and deciduous trees and shrubs to provide visual screening of parking areas. Note: A detailed landscape plan that specifically addresses the quantities, sizes and types of plantings, as well as the proposed grading/berming, shall be submitted at the Detailed Plan Stage for each proposed development.

-
- D. A 100'-0" building and parking setback to be provided along the residential areas to a point approximately 100 feet south of W. Calumet Road, with preservation of existing wooded areas to the extent possible.
- E. A minimum building setback of 30 feet and parking setback of 30 feet to be provided from the future internal ring road right-of-way.
- F. The minimum spacing between buildings shall be the greater of: (1) 25 linear feet, or (2) one half the combined height of the two buildings in question.
- III. Required Off-Street Parking:
- A. Office/R&D Uses permitted Uses - A, B, C, D, E, I, J, K, L, N, O, R) - 1 space per 400 square feet of gross floor area, minimum.
- B. Other Uses (Permitted Uses - F, G, H, M, P).
1. Type "A" Restaurants - 1 space per 125 square feet of gross floor area.
 2. Commercial hotel or motel - 1 space per room plus 1 space per 400 square feet of net lobby area and/or administrative office space.
 3. Public building intended for general public utilization including meeting room, community centers and libraries - 1 space per 300 square feet of gross floor area.
 4. Privately operated indoor recreation facilities including racquetball clubs, exercise clubs and movie theaters - required parking to be determined at the detailed plan stage.
- C. Unless designated for "Small Cars Only", the design of all off-street parking spaces shall comply with applicable standards of the Milwaukee Zoning Ordinance. Up to 25 percent of the parking spaces required for office and research and development uses may be designated for "Small Cars Only". All spaces so designated shall not be smaller than 8-1/2 feet wide by 16 feet long.
- D. No parking to be permitted within 25 feet of the public R.O.W. except along W. Park Place, where the parking setback shall be a minimum of 5 feet. No parking to be permitted within 25 feet of lands zoned for residential use.

- E. Common parking areas serving more than one building or more than permitted. However, the total number of spaces required to serve building must be located within 500 feet of said building.
 - F. All required parking shall be provided in off-street parking areas. No on-street parking shall be permitted.
-

IV. Signage Standards:

- A. Construction Signs - signage pertaining to the construction of a building not exceeding 36 square feet may be located on the premises and must be removed upon completion of construction.
- B. Project Signs - signage pertaining to the overall development or a major component, may be located at or near the entrance to the tract or component, with design, scale, material and location in harmony and complementary to the overall development and character of the surrounding area. This type of sign may be illuminated with the source of light not visible. The sign may not exceed 10 feet in height and character size may not exceed 18 inches.
- C. Building Identification Signs - one monument sign may be provided for each building indicating the building's name, ownership or major tenant. Their design, scale, material and location shall be complementary to the building. This type of sign may be illuminated with the source of light not visible.
- D. Directory Signs - monument signs identifying building tenants may be located at or near building entrances. Such signs shall be of a design, scale, material and location that are complementary to the building. Such signs shall not exceed 5 feet in height or an area of 16 square feet.
- E. Directional Signs - signs providing information for pedestrian or vehicular movement and signs providing street addresses, may be provided so long as the design, scale, material and location is complementary to the building. This type of sign may not be illuminated and shall not exceed 16 square feet.
- F. Additional Standards - notwithstanding the foregoing, the following standards shall apply where identified:
 - 1. Building Identification Signs:
 - a. In Areas A and B said monument sign shall not exceed 10 feet in height and may be located on a ground mounted pedestal averaging no more than one foot above grade. The sign area, or display face, shall not exceed an area of 50 square feet per face.

- b. In Areas C, D*, E, F and G said monument sign shall not exceed 5 feet in height and may be located on a ground mounted pedestal averaging no more than one foot above grade. The sign area, or display face, shall not exceed an area of 32 square feet per face.

* In Area D buildings adjacent to West Park Place may place their identification sign on the building's façade most parallel to and facing U.S. Highways 41 & 45.

2. Tenant Signs:

- a. In Area A buildings may install no more than one wall sign per tenant, per street exposure, mounted parallel to the building's facade or other building surface. Each wall sign shall not exceed 20 square feet and shall be of a uniform type, size and color for each building. Only individual letters and symbols are acceptable. In the event that unusual circumstances support a deviation from this standard, the Common Council may approve additional signage at the Detailed Plan stage or as a minor modification.
- b. In Area B buildings may install no more than two wall signs identifying the building's major tenants, mounted parallel to the building's facade most parallel to and facing U.S. Highways 41 & 45. Wall signs shall not exceed 20 square feet for buildings up to 4 stories and 32 square feet for buildings of 5 to 11 stories. For buildings of 12 or more stories, wall signs shall not exceed 4 feet in height or 225 square feet of area. Said signs shall be of a uniform type, size and color for each building. Only individual letters and symbols are acceptable. In the event that unusual circumstances support a deviation from this standard, the Common Council may approve additional signage at the Detailed Plan stage or as a minor modification.

Miscellaneous Design Standards:

- A. The vehicular circulation system should be laid out in such a way that:
1. The traffic circulation facilities within and to the tract shall provide for safe and convenient movement of pedestrians and vehicles, including accessibility by emergency, municipal, and delivery vehicles. The development of these facilities in the non-public sectors of the tract shall be in conformance with the standards of the American Concrete Institute and/or the Asphalt Institute or equivalent standards.
 2. The existing ring roads (north & south) are public roads to serve the interior areas of the project. Additionally, private drives will provide access within Area G.

3. No direct driveway connections from the site (Area A) to North 107th Street or West Good Hope Road would be possible.
 4. ~~Direct driveways may be permitted to W. Bradley Road from Area E and G if the parcel is at least 15 acres in size. The City may also develop and impose specific conditions and stipulations covering the design, use or length of time said driveways might be utilized.~~
 5. ~~Parcels in Areas A, B and C shall connect to any and all abutting streets except for West Calumet and Good Hope Roads.~~
- B. Unpaved areas shall be landscaped and continuously maintained. Landscaping shall be installed simultaneously with the completion of each development phase. The developer as part of any Detailed Plan application shall file a landscaping plan. Said landscaping plan shall be reflective of the following design objectives:
1. Any automobile parking area having more than 10 parking spaces shall include interior landscaping such as landscaped bays or islands. The total amount of interior landscaping shall equal not less than 5 square feet per parking stall. This interior landscaping standard shall apply only to Permitted Uses A, B, C, and G only and excludes parking decks and research & development uses in Area D and E.
 2. Berming and/or clusters of dense planting, where appropriate, will be used to screen parking and loading/unloading facilities from nearby areas.
 3. Land use buffering to screen parking from roads and residential areas shall meet or exceed the level of screening required by Section 295-75.
- C. Areas A, B, C, D, E, F & G shall be developed exclusively with Permitted Uses as shown on Exhibit D-1 Area Schedule.
- D. The illumination of the tract shall conform to the established standards used by the City of Milwaukee for purposes similar to the uses of each area of the plan.
- E. The electric power, telephone and tract illumination lines shall be installed underground, in easements when required, provided that transformers and substations may be installed within accessory buildings.
- F. The exterior materials of buildings are subject to City review in the Detailed Plan stage. Corrugated metal buildings ('Butler' type) will not be permitted.
- G. Daycare facilities shall conform to City of Milwaukee standards including:
1. Play area meeting state standards shall be entirely fenced.
 2. There shall be a designated drop-off and pick-up area.

- H. Maximum height of building may be increased for purposes of screening mechanical equipment and/or for skylights, subject to Common Council approval.

~~I. All rooftop mechanical equipment must be physically screened with a material and of a design that is integrated with the architecture.~~

- I. All dumpster/recycling areas are to be fully enclosed on four sides and screened from public view.
-
- J. The existing trees around the existing man-made lake are to be preserved to the extent possible, especially around the bay areas, as denoted on the amended General Plan.
- K. The developer(s) shall enter into a maintenance agreement with the Park Place Association that ensures regular maintenance of the common areas of Park Place.
- L. All parcels shall provide for pedestrian circulation between major features of Park Place.

PROJECT:

e-FUNDS OFFICE MILWAUKEE, WISCONSIN

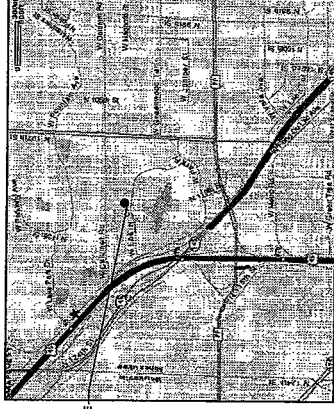

PROPOSED ONE
STORY OFFICE

① SITE VICINITY MAP

ISSUED FOR CITY REVIEW

OWNER:



LIBERTY PROPERTY TRUST MILWAUKEE, WISCONSIN

ARCHITECT:

STEPHEN PERRY SMITH ARCHITECTS, INC. MENOMONEE FALLS, WISCONSIN

DRAWING INDEX

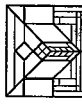
T10	TITLE PAGE
A00	MASTER SITE PLAN
A01	ARCHITECTURAL SITE PLAN
A11	BUILDING FLOOR PLANS
A12	BUILDING FLOOR PLAN
A41	BUILDING ELEVATIONS
L1	LANDSCAPE PLAN
L2	LANDSCAPE DETAIL
L3	LANDSCAPE SCHEDULE / NOTES

 STEPHEN PERRY SMITH ARCHITECTS 108 WEST MAIN STREET, SUITE 400 MILWAUKEE, WISCONSIN 53224 TELEPHONE: 262-574-4000 FACSIMILE: 262-574-4001	
PROJECT PROPOSED 1 STORY OFFICE BUILDING e-FUNDS AT PARK PLACE MILWAUKEE, WISCONSIN	
OWNER LIBERTY PROPERTY TRUST 1144 WEST PARK PLACE, SUITE 104 MILWAUKEE, WISCONSIN 53224 TELEPHONE: 414-979-0222 FACSIMILE: 414-979-0221	
CONTRACTOR  BERGHAMMER Construction Corporation 4750 GREEN VALLEY STREET P.O. BOX 918 MILWAUKEE, WISCONSIN 53224 PHONE: 262-790-4755 FAX: 262-790-4755	
SHEET TITLES PAGE SITE MAP	
REVISIONS ITEM DATE BY	
INFORMATION PROJECT ARCHITECT SP5 DRAWN BY MAM PROJECT NUMBER 1PT-01-08 ISSUED FOR CITY REVIEW DATE APRIL 11, 2005 SHEET NO.	
T1.0	

WEST CALUMET ROAD

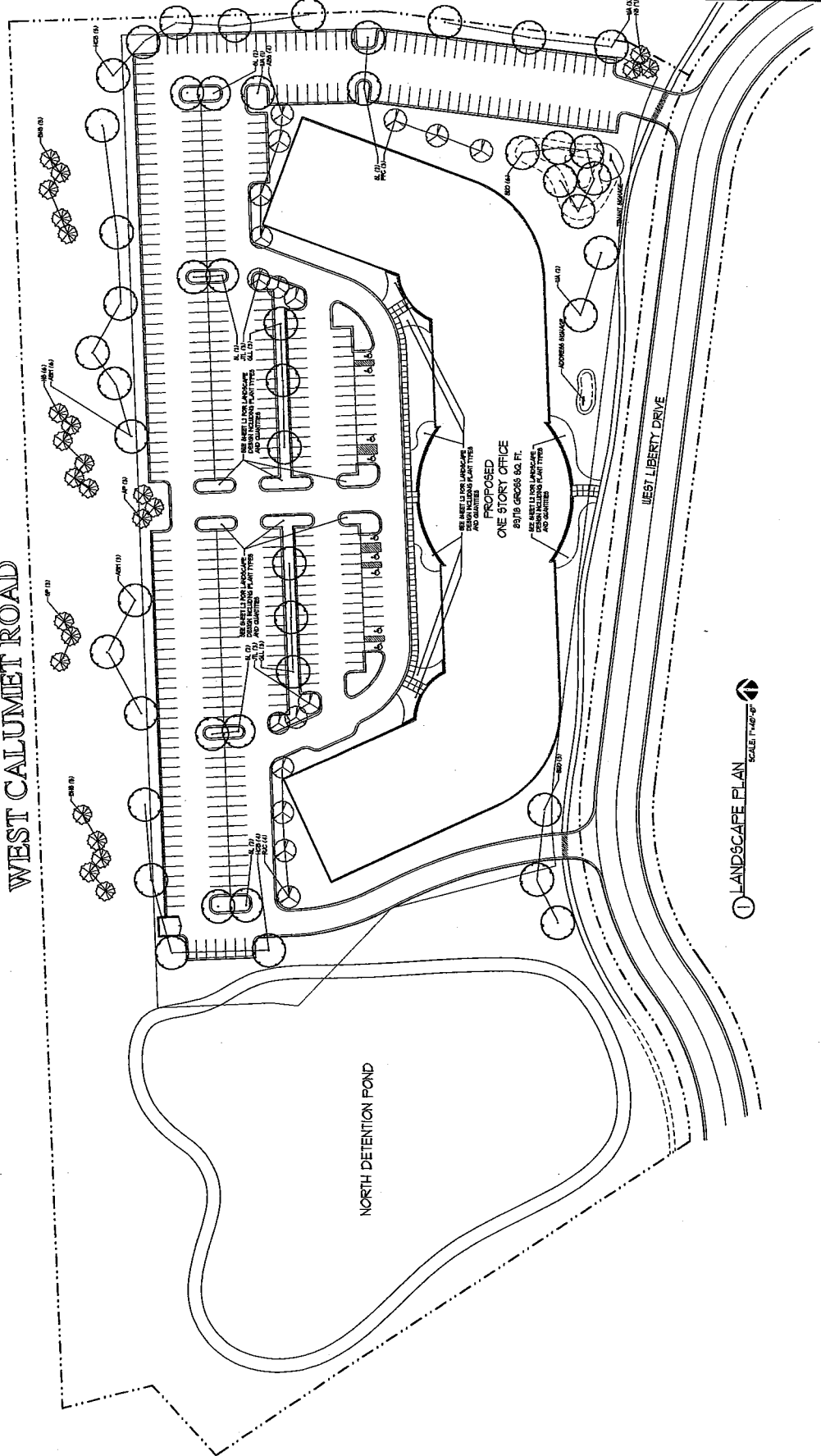

LANDSCAPE PLAN
SCALE 1"=40'-0"

 <p>STEPHEN PERRY SMITH ARCHITECTS</p> <p>185 WEST MAIN STREET, SUITE 400 MILWAUKEE, WISCONSIN 53033 TEL: 414-462-3323 FAX: 414-462-3344</p>	
<p>PROJECT</p> <p>PROPOSED 1 STORY OFFICE BUILDING</p> <p>e-FUNDS AT PARK PLACE MILWAUKEE, WISCONSIN</p>	
<p>OWNER</p> <p>LIBERTY PROPERTY TRUST</p> <p>1541 WEST PARK PLACE, SUITE 104 MILWAUKEE, WISCONSIN 53034 TEL: 414-462-3323 FAX: 414-462-3344</p>	
<p>CONTRACTOR</p> <p>BERGHAMMER Construction Corporation</p> <p>P.O. BOX 918 4750 NORTH 152ND STREET MILWAUKEE, WISCONSIN 53007 TEL: 414-462-3323 FAX: 414-462-3344</p>	
<p>SHEET</p> <p>LANDSCAPE PLAN</p>	
<p>CONSULTANT</p> <p>LANDSCAPE ARCHITECTS THOMAS MORTENSEN, ASLA JOHN F. PLATT, ASLA 4601 N. FLATT AVENUE MILWAUKEE, WISCONSIN 53222 TEL: 414-462-3323 FAX: 414-462-3344</p>	
<p>INFORMATION</p> <p>PROJECT ARCHITECT: SP3</p> <p>DRAWN BY: MAM</p> <p>PROJECT NUMBER: LFT-05-508</p> <p>ISSUED FOR: CITY REVIEW</p> <p>DATE: APRIL 11, 2002</p> <p>SHEET NO. L1</p>	



STEPHEN PERRY SMITH
ARCHITECTS

150 WIGHTMAN STREET, SUITE 400
MILWAUKEE, WISCONSIN 53211
PHONE: 414-224-4400
FACSIMILE: 414-224-4001

PROJECT

PROPOSED 1-STORY
OFFICE BUILDING
e-FUNDS
AT PARK PLACE
MILWAUKEE, WISCONSIN

OWNER

LIBERTY

PROPERTY TRUST
1144 WEST PARK BLVD. SUITE 104
MILWAUKEE, WISCONSIN 53214
TEL: 414-224-4400
FAX: 414-224-4001

CONTRACTOR

BERGHAMMER

Construction Corporation
P.O. BOX 818
4700 PARK BLVD. STREET
MILWAUKEE, WISCONSIN 53219
FAX: 262-790-4755

SHEET

MASTER SITE PLAN
77,000 SQ. FT. BUILDING

REVISIONS

ITEM DATE BY

INFORMATION

PROJECT ARCHITECT: SPS
DRAWN BY: MAM
PROJECT NUMBER: LPT-03-508
ISSUED FOR: CITY REVIEW
DATE: APRIL 11, 2005
SHEET NO.

A0.0



1 MASTER SITE PLAN
NOT TO SCALE

WEST CALUMET ROAD

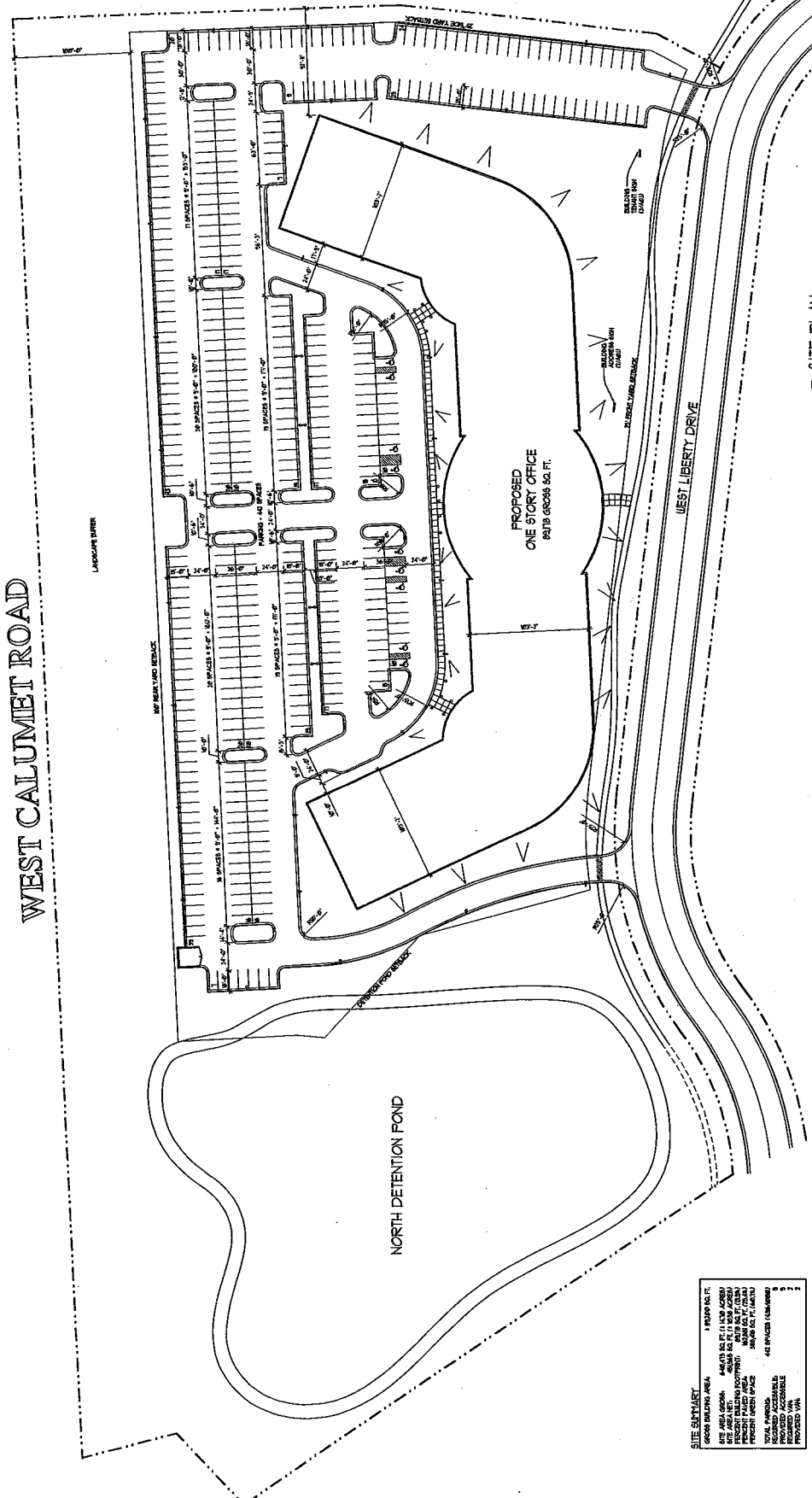

1 SITE PLAN
SCALE: 1"=60'-0"

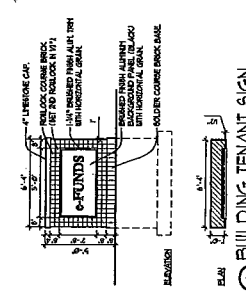

3 BUILDING TENANT SIGN
SCALE: 1/4"=1'-0"

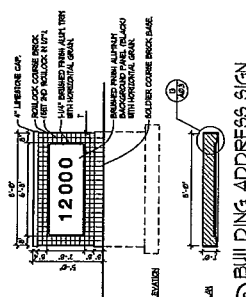

2 BUILDING ADDRESS SIGN
SCALE: 1/4"=1'-0"

SITE SUMMARY

1	12000 SQ. FT.
2	8976 GROSS SQ. FT.
3	11000 NET SQ. FT.
4	11000 NET SQ. FT.
5	11000 NET SQ. FT.
6	11000 NET SQ. FT.
7	11000 NET SQ. FT.
8	11000 NET SQ. FT.
9	11000 NET SQ. FT.
10	11000 NET SQ. FT.
11	11000 NET SQ. FT.
12	11000 NET SQ. FT.
13	11000 NET SQ. FT.
14	11000 NET SQ. FT.
15	11000 NET SQ. FT.
16	11000 NET SQ. FT.
17	11000 NET SQ. FT.
18	11000 NET SQ. FT.
19	11000 NET SQ. FT.
20	11000 NET SQ. FT.
21	11000 NET SQ. FT.
22	11000 NET SQ. FT.
23	11000 NET SQ. FT.
24	11000 NET SQ. FT.
25	11000 NET SQ. FT.
26	11000 NET SQ. FT.
27	11000 NET SQ. FT.
28	11000 NET SQ. FT.
29	11000 NET SQ. FT.
30	11000 NET SQ. FT.
31	11000 NET SQ. FT.
32	11000 NET SQ. FT.
33	11000 NET SQ. FT.
34	11000 NET SQ. FT.
35	11000 NET SQ. FT.
36	11000 NET SQ. FT.
37	11000 NET SQ. FT.
38	11000 NET SQ. FT.
39	11000 NET SQ. FT.
40	11000 NET SQ. FT.
41	11000 NET SQ. FT.
42	11000 NET SQ. FT.
43	11000 NET SQ. FT.
44	11000 NET SQ. FT.
45	11000 NET SQ. FT.
46	11000 NET SQ. FT.
47	11000 NET SQ. FT.
48	11000 NET SQ. FT.
49	11000 NET SQ. FT.
50	11000 NET SQ. FT.
51	11000 NET SQ. FT.
52	11000 NET SQ. FT.
53	11000 NET SQ. FT.
54	11000 NET SQ. FT.
55	11000 NET SQ. FT.
56	11000 NET SQ. FT.
57	11000 NET SQ. FT.
58	11000 NET SQ. FT.
59	11000 NET SQ. FT.
60	11000 NET SQ. FT.
61	11000 NET SQ. FT.
62	11000 NET SQ. FT.
63	11000 NET SQ. FT.
64	11000 NET SQ. FT.
65	11000 NET SQ. FT.
66	11000 NET SQ. FT.
67	11000 NET SQ. FT.
68	11000 NET SQ. FT.
69	11000 NET SQ. FT.
70	11000 NET SQ. FT.
71	11000 NET SQ. FT.
72	11000 NET SQ. FT.
73	11000 NET SQ. FT.
74	11000 NET SQ. FT.
75	11000 NET SQ. FT.
76	11000 NET SQ. FT.
77	11000 NET SQ. FT.
78	11000 NET SQ. FT.
79	11000 NET SQ. FT.
80	11000 NET SQ. FT.
81	11000 NET SQ. FT.
82	11000 NET SQ. FT.
83	11000 NET SQ. FT.
84	11000 NET SQ. FT.
85	11000 NET SQ. FT.
86	11000 NET SQ. FT.
87	11000 NET SQ. FT.
88	11000 NET SQ. FT.
89	11000 NET SQ. FT.
90	11000 NET SQ. FT.
91	11000 NET SQ. FT.
92	11000 NET SQ. FT.
93	11000 NET SQ. FT.
94	11000 NET SQ. FT.
95	11000 NET SQ. FT.
96	11000 NET SQ. FT.
97	11000 NET SQ. FT.
98	11000 NET SQ. FT.
99	11000 NET SQ. FT.
100	11000 NET SQ. FT.

SITE LIGHTING

1	TRAFFIC LIGHTS
2	STREET LIGHTS
3	AREA LIGHTS
4	PARADE LIGHTS
5	SCENE LIGHTS
6	SCENE LIGHTS
7	SCENE LIGHTS
8	SCENE LIGHTS
9	SCENE LIGHTS
10	SCENE LIGHTS
11	SCENE LIGHTS
12	SCENE LIGHTS
13	SCENE LIGHTS
14	SCENE LIGHTS
15	SCENE LIGHTS
16	SCENE LIGHTS
17	SCENE LIGHTS
18	SCENE LIGHTS
19	SCENE LIGHTS
20	SCENE LIGHTS
21	SCENE LIGHTS
22	SCENE LIGHTS
23	SCENE LIGHTS
24	SCENE LIGHTS
25	SCENE LIGHTS
26	SCENE LIGHTS
27	SCENE LIGHTS
28	SCENE LIGHTS
29	SCENE LIGHTS
30	SCENE LIGHTS
31	SCENE LIGHTS
32	SCENE LIGHTS
33	SCENE LIGHTS
34	SCENE LIGHTS
35	SCENE LIGHTS
36	SCENE LIGHTS
37	SCENE LIGHTS
38	SCENE LIGHTS
39	SCENE LIGHTS
40	SCENE LIGHTS
41	SCENE LIGHTS
42	SCENE LIGHTS
43	SCENE LIGHTS
44	SCENE LIGHTS
45	SCENE LIGHTS
46	SCENE LIGHTS
47	SCENE LIGHTS
48	SCENE LIGHTS
49	SCENE LIGHTS
50	SCENE LIGHTS
51	SCENE LIGHTS
52	SCENE LIGHTS
53	SCENE LIGHTS
54	SCENE LIGHTS
55	SCENE LIGHTS
56	SCENE LIGHTS
57	SCENE LIGHTS
58	SCENE LIGHTS
59	SCENE LIGHTS
60	SCENE LIGHTS
61	SCENE LIGHTS
62	SCENE LIGHTS
63	SCENE LIGHTS
64	SCENE LIGHTS
65	SCENE LIGHTS
66	SCENE LIGHTS
67	SCENE LIGHTS
68	SCENE LIGHTS
69	SCENE LIGHTS
70	SCENE LIGHTS
71	SCENE LIGHTS
72	SCENE LIGHTS
73	SCENE LIGHTS
74	SCENE LIGHTS
75	SCENE LIGHTS
76	SCENE LIGHTS
77	SCENE LIGHTS
78	SCENE LIGHTS
79	SCENE LIGHTS
80	SCENE LIGHTS
81	SCENE LIGHTS
82	SCENE LIGHTS
83	SCENE LIGHTS
84	SCENE LIGHTS
85	SCENE LIGHTS
86	SCENE LIGHTS
87	SCENE LIGHTS
88	SCENE LIGHTS
89	SCENE LIGHTS
90	SCENE LIGHTS
91	SCENE LIGHTS
92	SCENE LIGHTS
93	SCENE LIGHTS
94	SCENE LIGHTS
95	SCENE LIGHTS
96	SCENE LIGHTS
97	SCENE LIGHTS
98	SCENE LIGHTS
99	SCENE LIGHTS
100	SCENE LIGHTS

<p>STEPHEN PERRY SMITH ARCHITECTS 304 WEST MAIN STREET, SUITE 400 MILWAUKEE, WISCONSIN 53212 PHONE: 414-224-4001 FACSIMILE: 414-224-4001</p>							
<p>PROJECT PROPOSED 1 STORY OFFICES BUILDING e-FUNDS AT PARK PLACE MILWAUKEE, WISCONSIN</p>							
<p>OWNER LIBERTY PROPERTY TRUST 1144 WEST BAYVIEW AVENUE, SUITE 104 MILWAUKEE, WISCONSIN 53224 TELEPHONE: 414-978-0222 FACSIMILE: 414-978-0221</p>							
<p>CONTRACTOR BERGHAMMER Construction Corporation P.O. BOX 818 4750 WEST WISCONSIN STREET MILWAUKEE, WISCONSIN 53224 PHONE: 414-224-4750 FAX: 414-224-4755</p>							
<p>SHEET ARCHITECTURAL SITE PLAN 89,736 SQ. FT. BUILDING</p>							
<p>REVISIONS</p> <table border="1"> <thead> <tr> <th>ITEM</th> <th>DATE</th> <th>BY</th> </tr> </thead> <tbody> <tr> <td> </td> <td> </td> <td> </td> </tr> </tbody> </table>		ITEM	DATE	BY			
ITEM	DATE	BY					
<p>INFORMATION</p> <p>PROJECT ARCHITECT SPS</p> <p>DRAWN BY MMK</p> <p>PROJECT NUMBER LPT-03-038</p> <p>ISSUED FOR CITY REVIEW</p> <p>DATE APRIL 11, 2005</p> <p>SHEET NO. A0.1</p>							



STEPHEN PERRY SMITH
ARCHITECTS

188 WISCONSIN MAIN STREET, SUITE 400
MILWAUKEE, WISCONSIN 53101
TELEPHONE: 414-979-0222
FACSIMILE: 414-979-4601

PROJECT

PROPOSED 1-STORY
OFFICE BUILDING
e-FUNDS
AT PARK PLACE
MILWAUKEE, WISCONSIN

OWNER

LIBERTY
PROPERTY TRUST
1144 WEST PARK PLACE, SUITE 104
MILWAUKEE, WISCONSIN 53214
TELEPHONE: 414-979-0222
FACSIMILE: 414-979-0221

CONTRACTOR

BERGHAMMER
Construction Corporation
P.O. BOX 918
4750 W. WISCONSIN TRUST
MILWAUKEE, WISCONSIN 53227
PHONE: 414-979-4755
FAX: 414-979-4755

SHEET

BUILDING FLOOR PLAN

REVISIONS

ITEM DATE BY

INFORMATION

PROJECT ARCHITECT: SP8
DRAWN BY: MAM
PROJECT NUMBER: 1PT-03-588
ISSUED FOR: CITY REVIEW
DATE: APRIL 11, 2005
SHEET NO.

A1.1

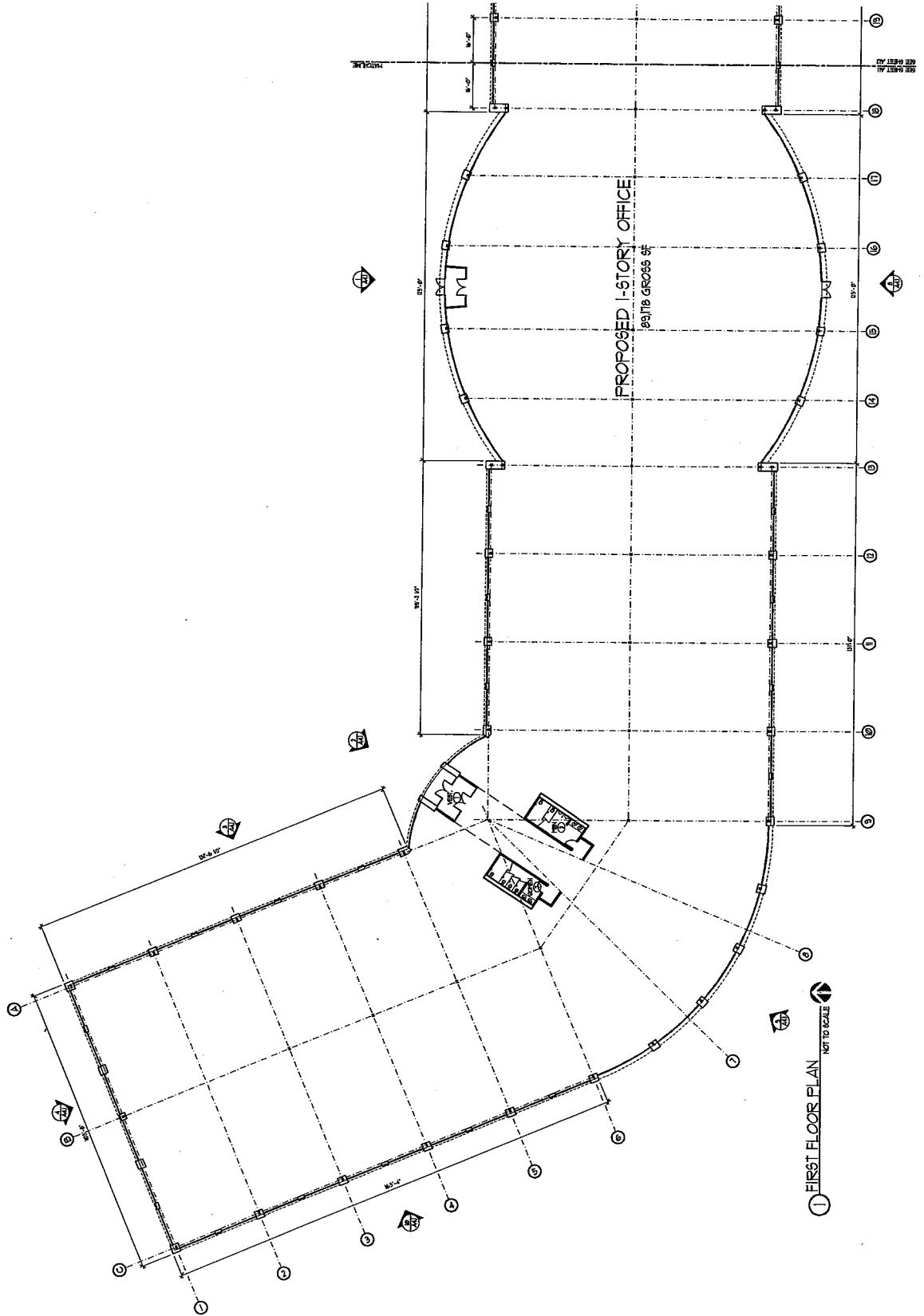



**STEPHEN PERRY SMITH
ARCHITECTS**

188 W 164th MAIN STREET, SUITE 400
NEW YORK, NY 10032
TELEPHONE: 212-477-4001
FACSIMILE: 212-477-4001

PROJECT

PROPOSED 1-STORY
OFFICE BUILDING
**e-FUNDS
AT PARK PLACE**
MANHATTAN, NEW YORK

OWNER

LIBERTY
PROPERTY TRUST
114 W 16th ST, 11th FLOOR, NEW YORK, NY 10011
TELEPHONE: 212-477-0222
FACSIMILE: 212-477-0221

CONTRACTOR

BERGHAMMER
Construction Corporation
P.O. BOX 318
4750 PARK BLVD, NEW YORK, NY 10024
TELEPHONE: 212-790-4755
FACSIMILE: 212-790-4755

SHEET

BUILDING FLOOR PLAN

REVISIONS

ITEM	DATE	BY

INFORMATION

PROJECT ARCHITECT	SPS
DRAWN BY	MAN
PROJECT NUMBER	LPT-03-508
ISSUED FOR	CITY REVIEW
DATE	APRIL 11, 2005
SHEET NO.	

A1.2

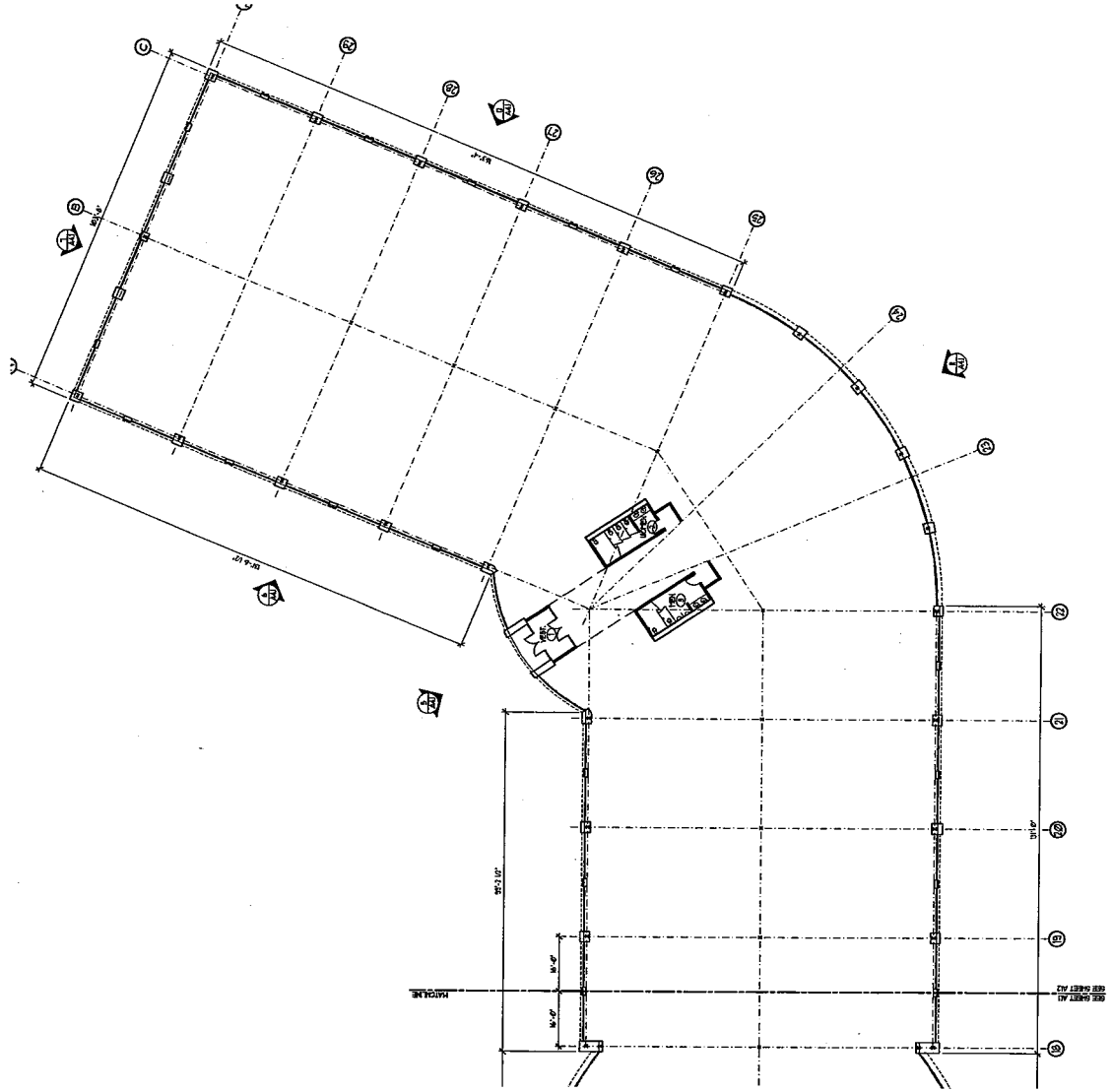

① FIRST FLOOR PLAN
NOT TO SCALE

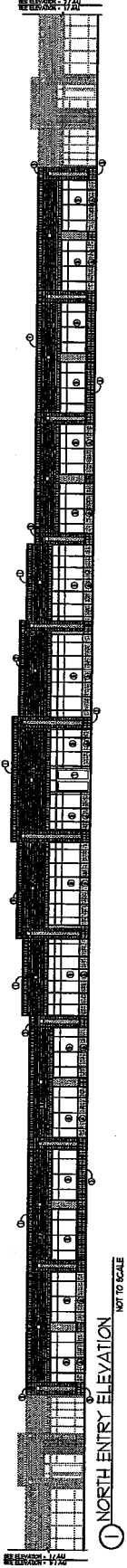

① NORTH ENTRY ELEVATION
NOT TO SCALE

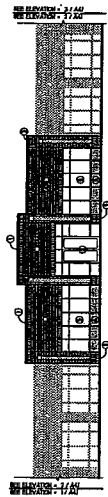

② NORTH-WEST ENTRY ELEVATION
NOT TO SCALE

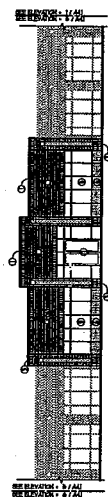

③ NORTH-EAST ENTRY ELEVATION
NOT TO SCALE

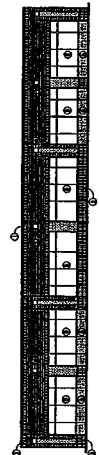

④ NORTH WING ELEVATION (EAST)
NOT TO SCALE

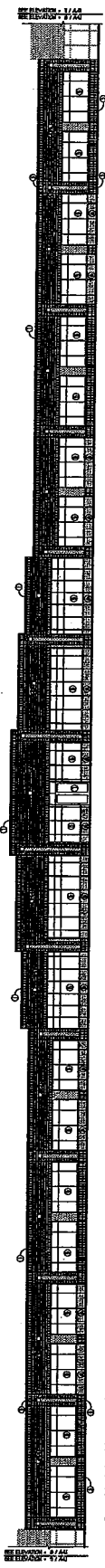

⑤ SOUTH ENTRY ELEVATION
NOT TO SCALE

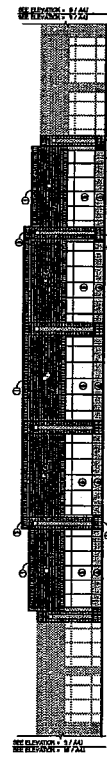

⑥ SOUTH-WEST CURVED ELEVATION
NOT TO SCALE

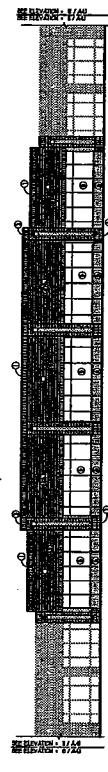

⑦ SOUTH-EAST CURVED ELEVATION
NOT TO SCALE

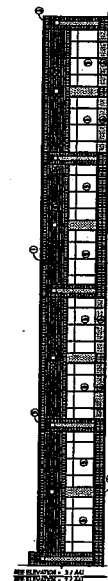

⑧ NORTH-WEST ELEVATION
NOT TO SCALE

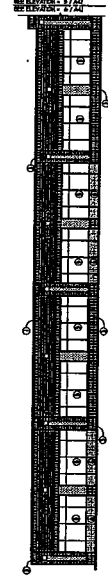

⑨ NORTH-EAST ELEVATION
NOT TO SCALE

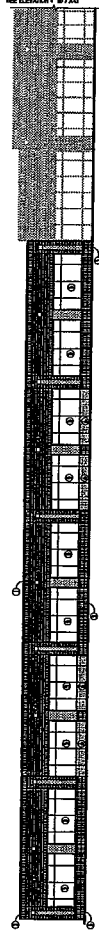

⑩ SOUTH-WEST WING ELEVATION
NOT TO SCALE

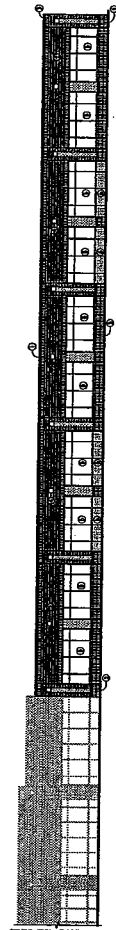

⑪ SOUTH-EAST WING ELEVATION
NOT TO SCALE

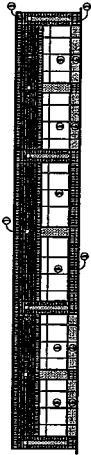

⑫ NORTH WING ELEVATION (WEST)
NOT TO SCALE

- MARKING SYSTEM**
- ① FINISHED SURFACE GRADE, TOP
 - ② FINISHED SURFACE GRADE, BOTTOM
 - ③ FINISHED SURFACE GRADE, CENTER
 - ④ FINISHED SURFACE GRADE, BOTTOM
 - ⑤ FINISHED SURFACE GRADE, TOP
 - ⑥ FINISHED SURFACE GRADE, CENTER
 - ⑦ FINISHED SURFACE GRADE, TOP
 - ⑧ FINISHED SURFACE GRADE, CENTER
 - ⑨ FINISHED SURFACE GRADE, BOTTOM
 - ⑩ FINISHED SURFACE GRADE, TOP
 - ⑪ FINISHED SURFACE GRADE, CENTER
 - ⑫ FINISHED SURFACE GRADE, BOTTOM

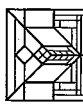
 STEPHEN PERRY SMITH ARCHITECTS		300 WEST MAIN STREET, SUITE 400 MILWAUKEE, WISCONSIN 53201 TEL: 414-224-4000 FAX: 414-224-4001	
PROJECT PROPOSED 1-STORY OFFICE BUILDING		e-FUNDS AT PARK PLACE MILWAUKEE, WISCONSIN	
OWNER LIBERTY PROPERTY TRUST 1144 WEST PARK PLACE, SUITE 104 MILWAUKEE, WISCONSIN 53224 TEL: 414-224-0222 FAX: 414-224-0221		CONTRACTOR BERGHAMMER Construction Corporation P.O. BOX 818 4750 W. WISCONSIN AVENUE MILWAUKEE, WISCONSIN 53228 TEL: 414-224-4750 FAX: 414-224-4755	
SHEET BUILDING ELEVATIONS KEYNOTES		REVISIONS ITEM DATE BY	
INFORMATION PROJECT ARCHITECT EPS DRAWN BY MAM PROJECT NUMBER 1PT-03-008 ISSUED FOR CITY REVIEW DATE APRIL 11, 2003 SHEET NO.		A4.1	