



LIVING WITH HISTORY

Certificate of Appropriateness

Milwaukee Historic Preservation Commission/200 E. Wells Street/Milwaukee, WI 53202/phone 414-286-5712/fax 414-286-3004

Property 2683 N. SUMMIT AV. North Point North Historic District

Description of work Electric box with conduit is located too close to water faucet at rear of house. Faucet will be moved to the right of the basement window as shown in accompanying photo. .

Date issued 11/19/2020 PTS ID 115058 COA CC File Number 201094

In accordance with the provisions of Section 320-21 (11) and (12) of the Milwaukee Code of Ordinances, the Milwaukee Historic Preservation Commission has issued a certificate of appropriateness for the work listed above. The work was found to be consistent with preservation guidelines. The following conditions apply to this certificate of appropriateness:

Stucco must be patched and returned to its historic appearance after work is done.

All work must be done in a craftsman-like manner, and must be completed within one year of the date this certificate was issued. Staff must approve any changes or additions to this certificate before work begins. Work that is not completed in accordance with this certificate may be subject to correction orders or citations. If you require technical assistance, please contact Carlen Hatala of the Historic Preservation staff as follows: Phone: (414) 286-5722 E-mail: carlen.hatala@milwaukee.gov.

If permits are required, you are responsible for obtaining them from the Milwaukee Development Center. If you have questions about permit requirements, please consult the Development Center's web site, www.milwaukee.gov/build, or call (414) 286-8210.

City of Milwaukee Historic Preservation Staff

Copies to: Development Center, Ald. Kovac

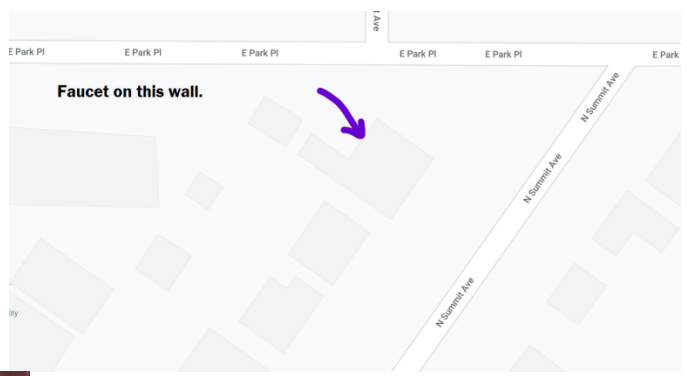
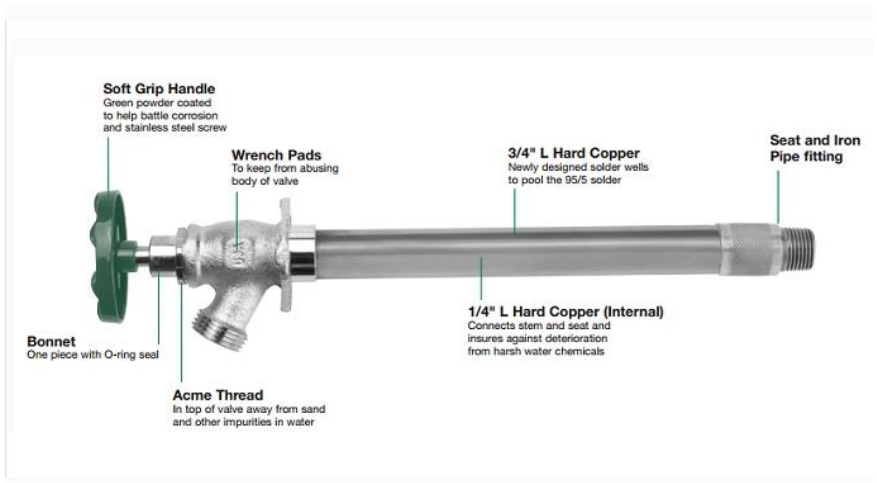

Rear of House



Front of House