

HISTORIC TEWELES SEED COMPANY LOFT APARTMENTS

222 S. 3rd St., Milwaukee, WI
3rd Coast Design Concepts Project No.: 0106

JULY 15, 2002

FINAL COPY
EXHIBIT A
File No. 010724
ZND/lcc

LIST OF CONSULTANTS/CONTRACTORS

OWNER
HISTORIC TEWELES SEED, LLC

DEVELOPERS
COMMOROND HOUSING &
ROBERT J. SCHULTZ DEVELOPMENT CO. LLC

MANAGEMENT
DOUG MAYO
COMMOROND HOUSING
828 KELLOGG BOULEVARD AVE.
ST. PAUL, MN 55102-1900
TEL: 651-991-1750
FAX: 651-991-1008

ARCHITECT
ROBERT J. SCHULTZ
ARCHITECT
14860 W MAYFLOWER CT.
NEW BERLIN, WI 53151
TEL: 262-891-9488
FAX: 262-891-9741

GENERAL CONTRACTOR
MARK HEINEN
A.J. HEINEN, INC.
19805 W. LINCOLN AVENUE
NEW BERLIN, WI 53151
TEL: 262-547-1692
FAX: 262-547-1690

STRUCTURAL ENGINEERING
TOM DECKER, P.E.
AMERSE ENGINEERING
W67 N222 EVERGREEN BLVD.
CEDARBURG, WI 53012
TEL: 262-377-7607
FAX: 262-377-4868

MECHANICAL DESIGN BUILDER
STEVE SAMS
CONDITIONED AIR INC.
TEL: 414-546-9090

MECHANICAL CONSULTANT
TO BE DETERMINED

ELECTRICAL DESIGN BUILDER
JIM KURACHERSKI
ROMAN ELECTRIC
TEL: 414-771-5400

ELECTRICAL CONSULTANT
TO BE DETERMINED

PLUMBING DESIGN BUILDER
ALPINE PLUMBING
TEL: 262-797-4180

PLUMBING CONSULTANT
TO BE DETERMINED

FIRE SPRINKLER DESIGN BUILDER
U.S. FIRE PROTECTION

COST CONSULTANT
MARK LABONTE

ADMINISTRATION
BILL WEISSERT
TWO PLAZA EAST, SUITE 550
390 EAST KILBOURN AVE.
MILWAUKEE, WI 53202-3144
TEL: 414-390-1178

MARKETING CONSULTANT
ODGEN & COMPANY

PLOTTING SERVICES
CHARLES NABER
WEST ALLIS BLDERINT & SUPPLY, INC.
AND ENGINEERING SERVICES
6801 WEST LINCOLN AVENUE
WEST ALLIS, WI 53219
TEL: 414-321-1422
FAX: 414-321-4616
WEB: www.westallshhprint.com

FURNISHINGS CONSULTANT
TO BE DETERMINED

GOVERNMENT LIASON
DENNIS HATCH

INTERIOR DESIGN
TO BE DETERMINED

TABLES OF CONTENTS

PG NO.	DESCRIPTION
T-1	TITLE SHEET
1	SITE PLAN
2	ALTERNATE PLAN FOR STREET ANGLE PARKING & SITE DETAILS
3	BASEMENT FLOOR PLAN
4	1ST FLOOR PLAN
5	2ND FLOOR PLAN
6	3RD FLOOR PLAN
7	4TH FLOOR PLAN
8	5TH FLOOR PLAN
9	6TH FLOOR PLAN
10	7TH FLOOR PLAN
11	8TH FLOOR PLAN
12	9TH FLOOR PLAN
13	10TH FLOOR PLAN
14	11TH FLOOR PLAN
15	12TH FLOOR PLAN
16	PENTHOUSE LEVEL 1 (13TH FLOOR)
17	PENTHOUSE LEVEL 2 (14TH FLOOR)
18	WEST ELEVATION
19	EAST ELEVATION
20	SOUTH ELEVATION
21	NORTH ELEVATION
22	EXTERIOR DETAILS
23	EXTERIOR DETAILS
24	ALTERNATE ROOF PLAN (BASKETBALL COURT)

DATE ISSUED : 07/15/02

	
Architects and Planners Project Title	
TEWELES SEED COMPANY LOFT APARTMENTS 222 S. THIRD STREET, MILWAUKEE, WISCONSIN	
Sheet Title TITLE SHEET	Signature Block Owner _____ Date _____ Architect _____ Builder _____ Surety _____
Proj. no. 07/15/02 Date 07/15/02 Check by RJS Drawn by BRS Revisions	SHEET T-1 OF 23 T-1

Logo 3rd Coast, Inc.

Architects and Planners

Project Title

TWELES SEED
COMPANY LOFT APARTMENTS
222 S. THIRD STREET, MILWAUKEE, WISCONSIN

Sheet Title
SITE PLAN

Structuring Block	Date
Owner	
Architect	
Builder	
Survey	
Proj. no.	0106
Date	07/25/02
Drawn by	RJS
Checked by	BRS
Revisions	

SHEET 1 OF 4

DATE ISSUED : 07/25/02

SITE PLAN

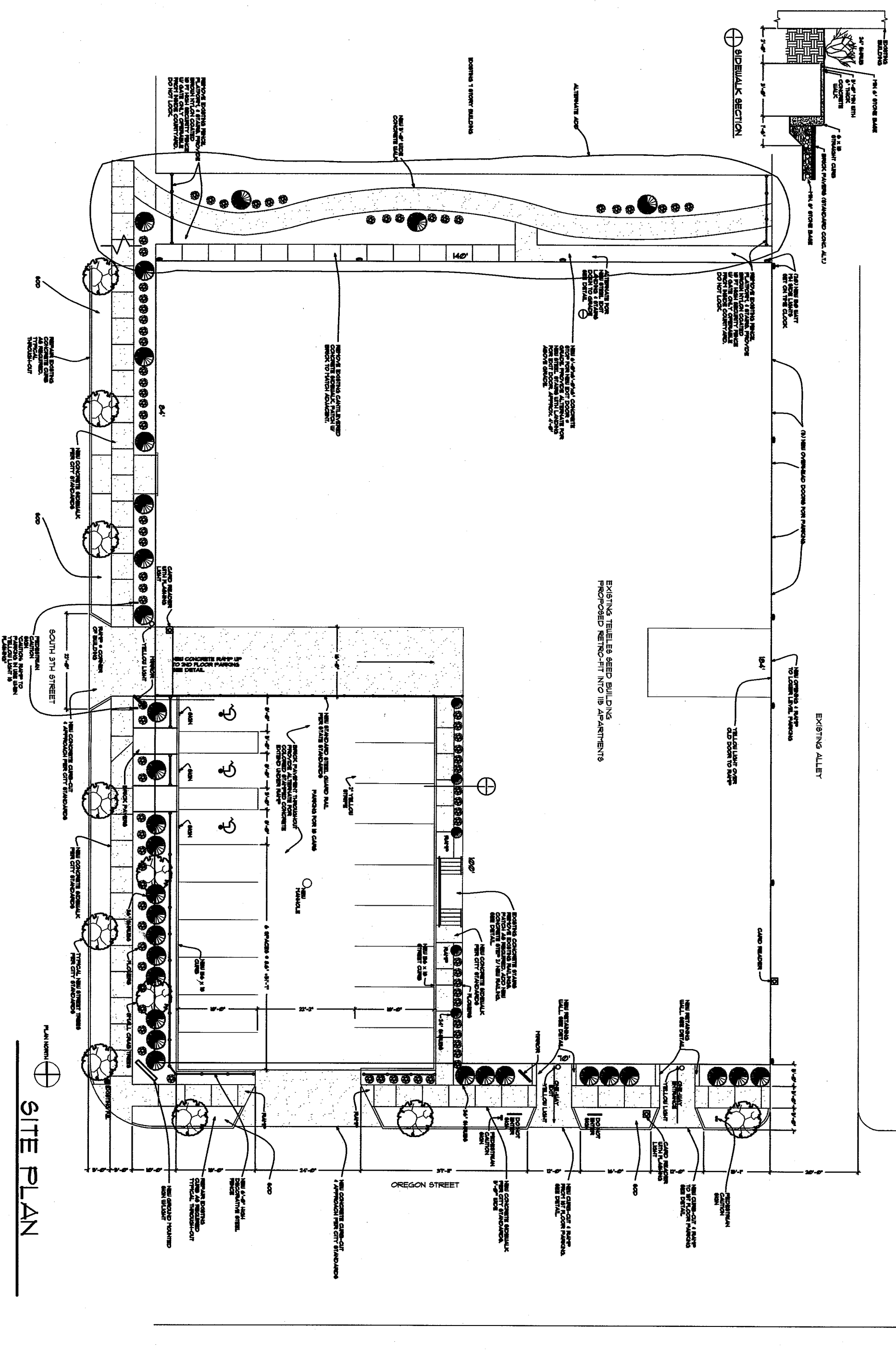

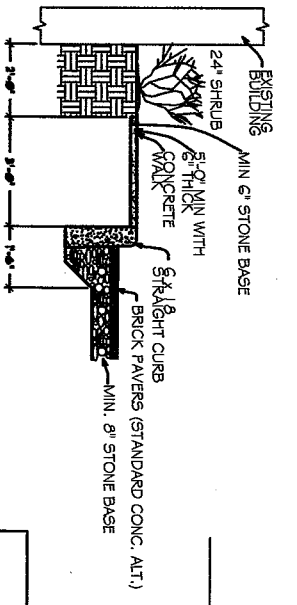

⊕ SIDEWALK SECTION

PLANT LISTING

MK QTY.	COMMON NAME	SCIENTIFIC NAME	SIZE AS PER CITY
A	CITY STREET TREE	VIBURNUM TRILOBUM (COMPACT)	1 GAL. POT
B	COMPACT AMERICAN CRANBERRY	ACER PLATANOIDES COLUMNAR	1 1/2" DIA. - 10 FT
C	COLUMNAR MAPLE	TRILIA OCCIDENTALIS PYRAMIDAL	3 FT
D	PYRAMID ARBOVITAE	SYRINGA VELUTINA DWARF	1 GAL. POT
E	DWARF KOREAN LILAC	LAVANDULA AUGUSTIFOLIA TWICKLE PURPLE	1 GAL. POT
F	ENGLISH LAVENDER	BERBERIS THUNBERGII CRIMSON PYGM	1 GAL. POT
G	JAPANESE BARBERRY	GIRARD HYBRID AZALEA	1 GAL. POT
H	GIRARD FLUCHSIA		

NOTES

1. PROVIDE HEAVY DUTY WEED BARRIER & WOOD BARK MULCH THROUGH ALL PLANTING AREAS
2. PROVIDE SOD & SIX INCHES OF TOP SOIL IN ALL SODDED AREAS
3. SEE SPECS FOR OTHER INFORMATION

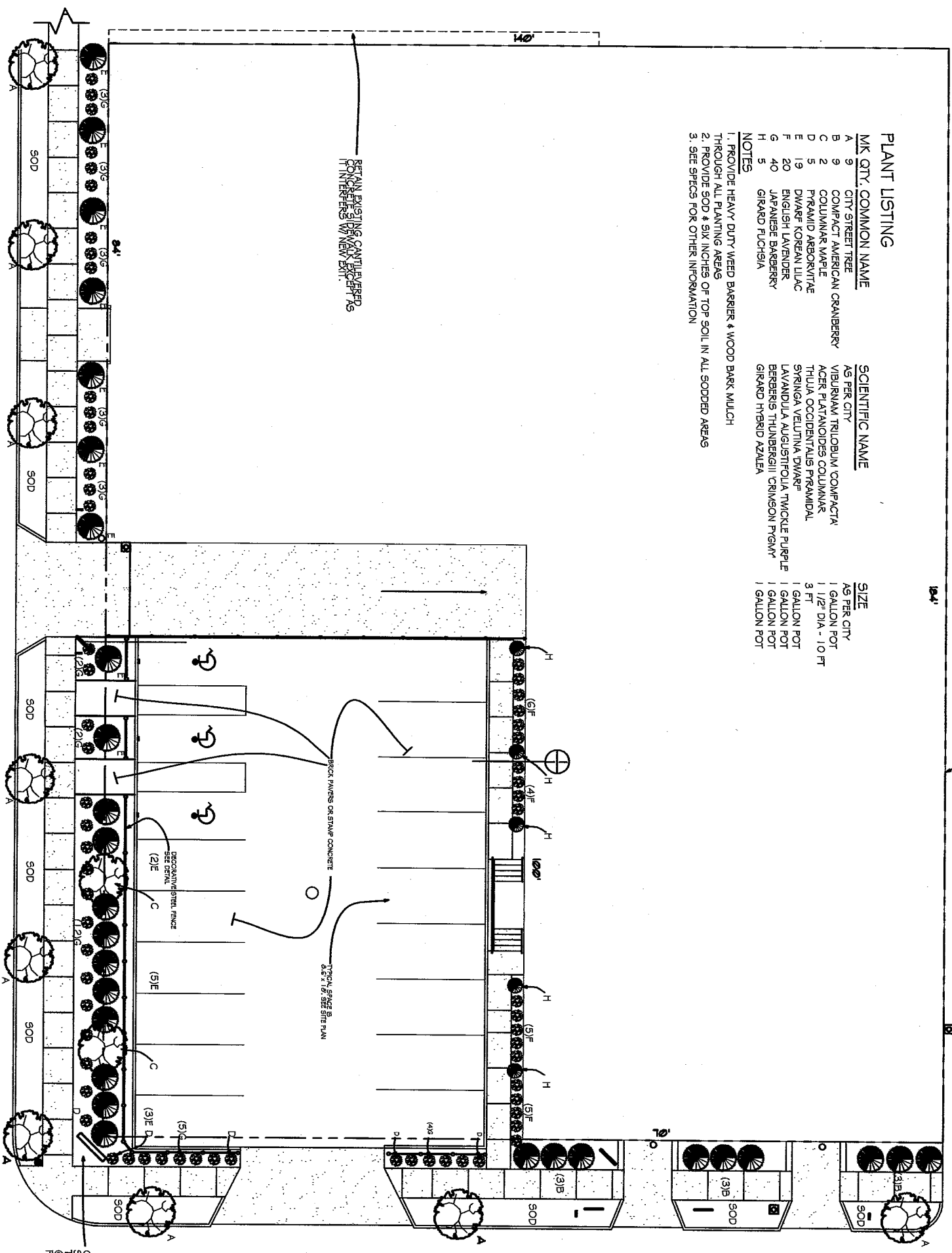

SOUTH 3TH STREET

OREGON STREET

EXISTING ALLEY

EXISTING SIGN

PLAN NORTH

LANDSCAPE PLAN

DATE ISSUED: 07/25/02

3rd Coast
Design Concepts
L.L.C.
©2000

Logo 3rd Coast/ll

Architects and Planners

Project Title

TEWELES SEED COMPANY LOFT APARTMENTS

222 S. THIRD STREET, MILWAUKEE, WISCONSIN

Sheet Title
LANDSCAPE PLAN

Signature Block _____ Date _____
Owner _____
Architect _____
Builder _____
Survey _____

Proj. no. 0108
Date 07/25/02
Check by RJS
Drawn by BRS

Revisions
SHEET 2 OF 3
2

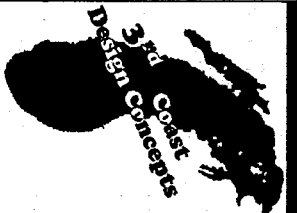

TEWELES SEED
COMPANY LOFT APARTMENTS
222 S. THIRD STREET, MILWAUKEE, WISCONSIN

Sheet Title

ALTERNATE STREET
PARKING
PLAN

Signature Block Date

Owner _____
Architect _____
Builder _____
Surety _____

Proj. no. 07109
Date 07/15/02
Drawn by RJS
Checked by ARS

Revisions

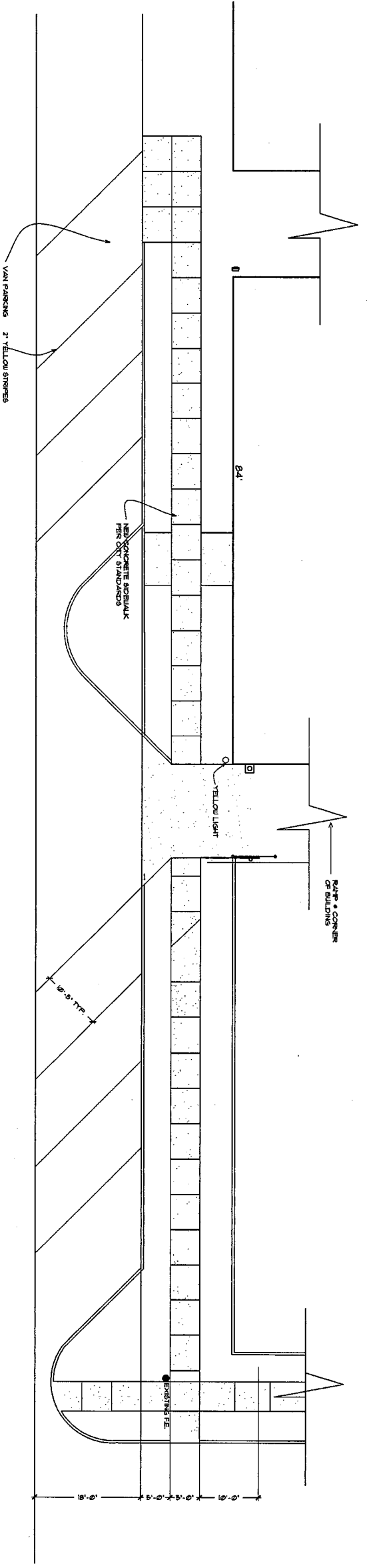

SCALE : 1" = 10'-0"

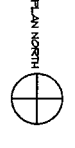

ALTERNATE STREET PARKING PLAN

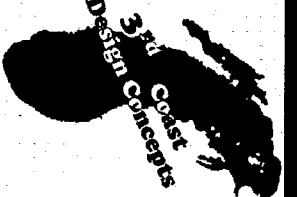

Architects and Planners

Project Title

**TWELES SEED
COMPANY LOFT APARTMENTS**
222 S. THIRD STREET, MILWAUKEE, WISCONSIN

Sheet Title

**BASEMENT
FLOOR PLAN**

Signature Block	Date
Owner	
Architect	
Builder	
Surety	
Proj. no.	0108
Date	07/15/02
Check by	RJS
Drawn by	BRS
Revisions	

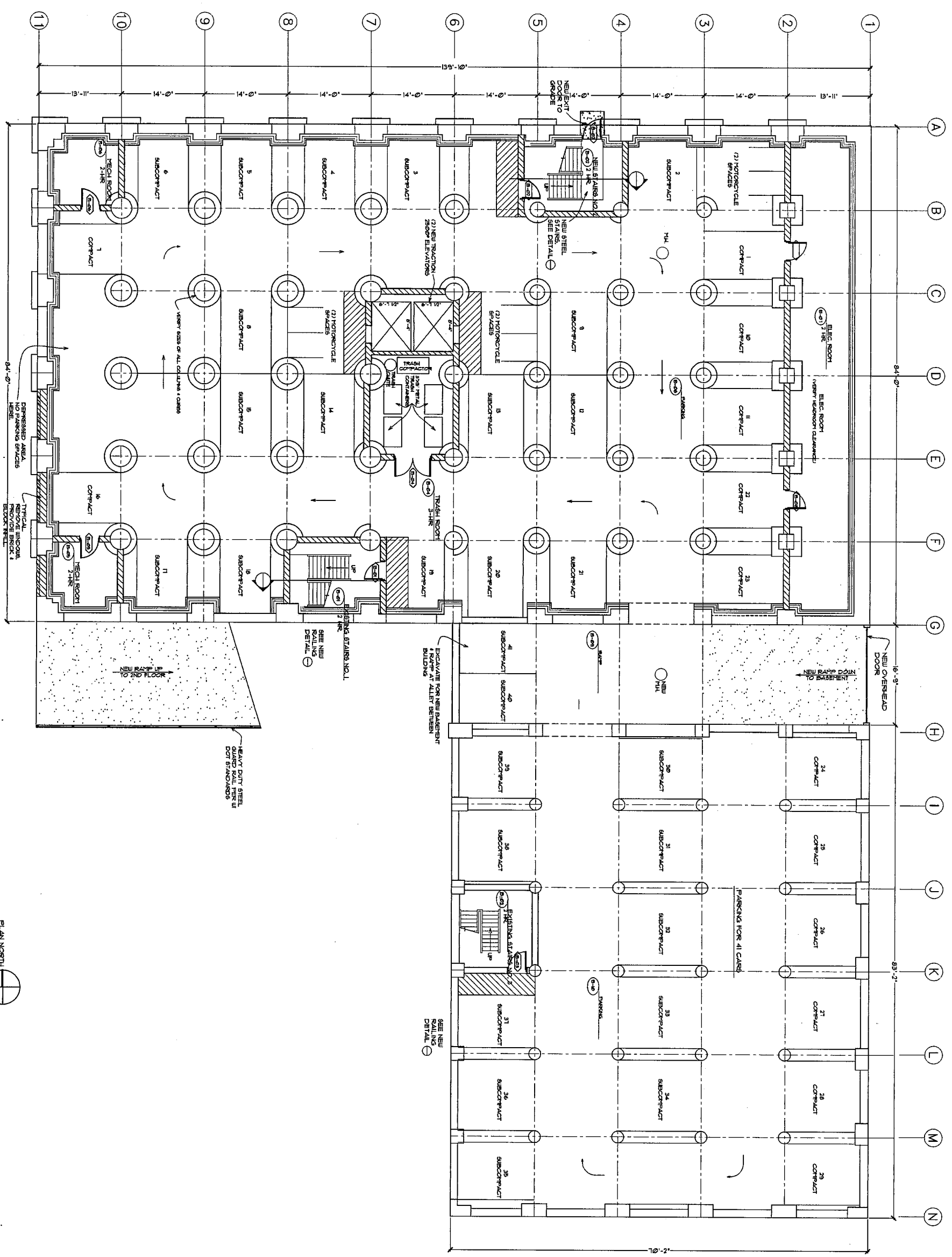

BASEMENT FLOOR PLAN

SCALE: 1/8" = 1'-0"
DATE ISSUED: 07/15/02

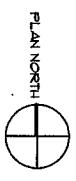

PLAN NORTH

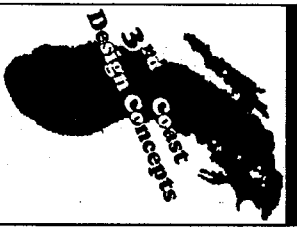

Architects and Planners

Project Title

**TWELES SEED
COMPANY LOFT APARTMENTS**
222 S. THIRD STREET, MILWAUKEE, WISCONSIN

Sheet Title

**FIRST FLOOR
PLAN**

Signature Block	Date
Owner	
Architect	
Builder	
Surety	
Proj. no.	07/1502
Date	07/15/02
Check by	R/S
Drawn by	BRS
Revisions	

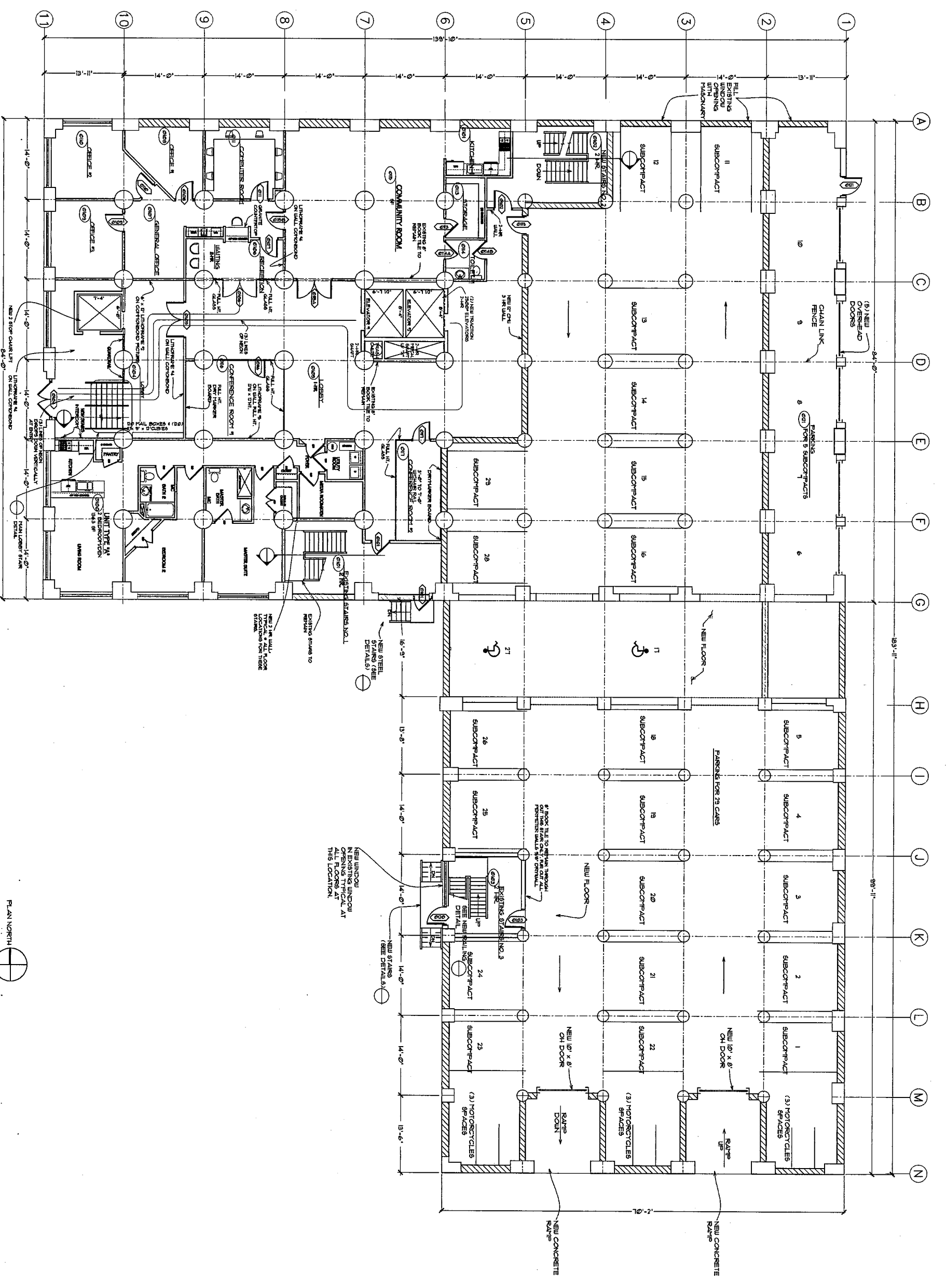

FIRST FLOOR PLAN

SCALE: 1/8" = 1'-0"
DATE ISSUED: 07/15/02

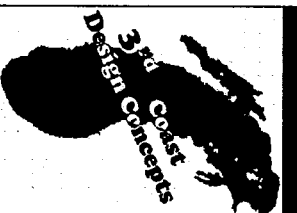

Architects and Planners

Project Title

**TWELES SEED
COMPANY LOFT APARTMENTS**
222 S. THIRD STREET, MILWAUKEE, WISCONSIN

Sheet Title
**SECOND FLOOR
PLAN**

Signature Block	Date
Owner	
Architect	
Builder	
Survey	
Proj. no.	0108
Date	07/15/02
Check By	RLS
Drawn By	BRS
Revisions	

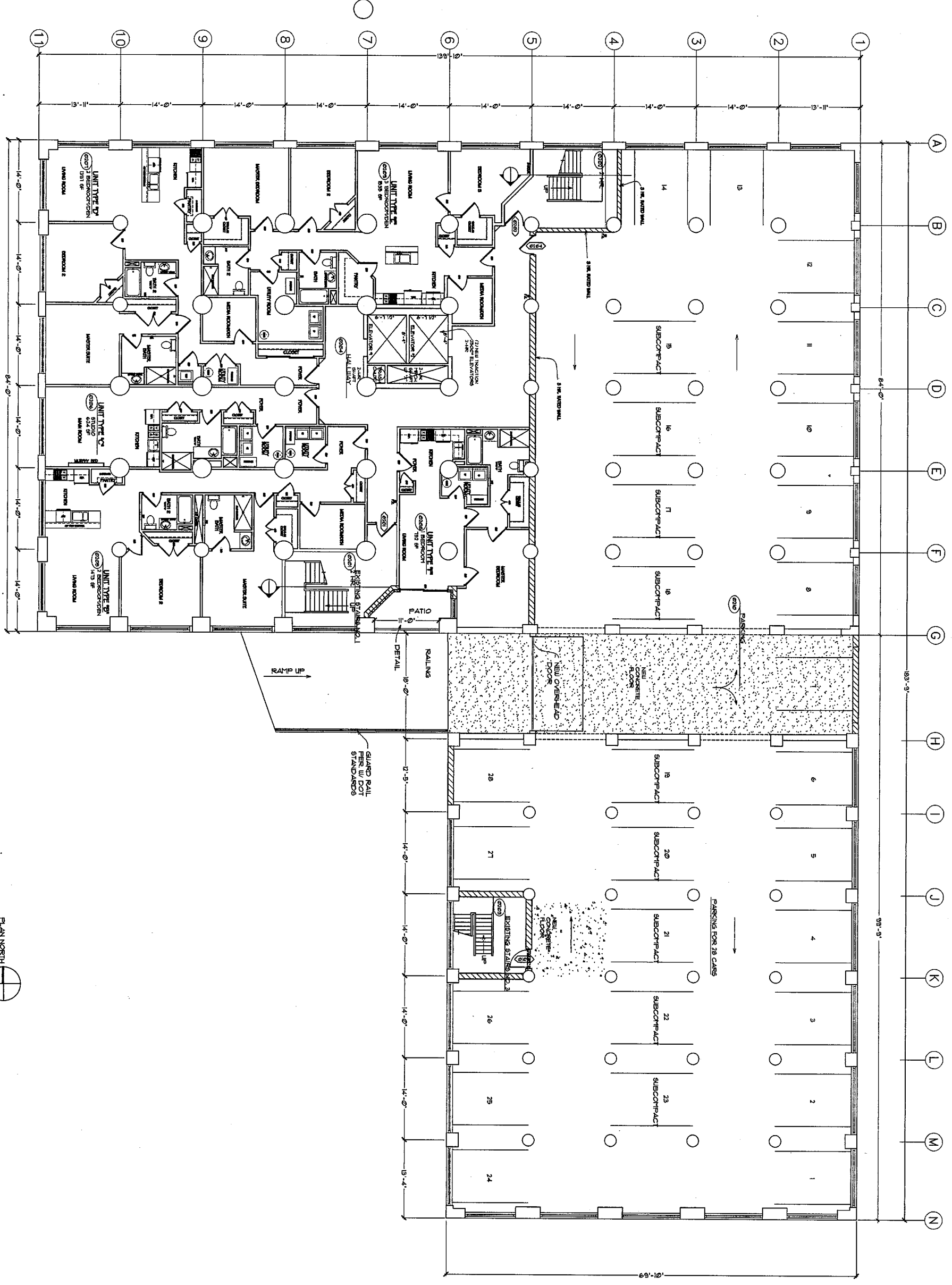

SECOND FLOOR PLAN

SCALE: 1/8" = 1'-0"
DATE ISSUED: 07/15/02

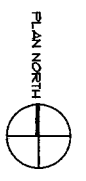

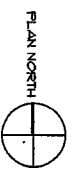
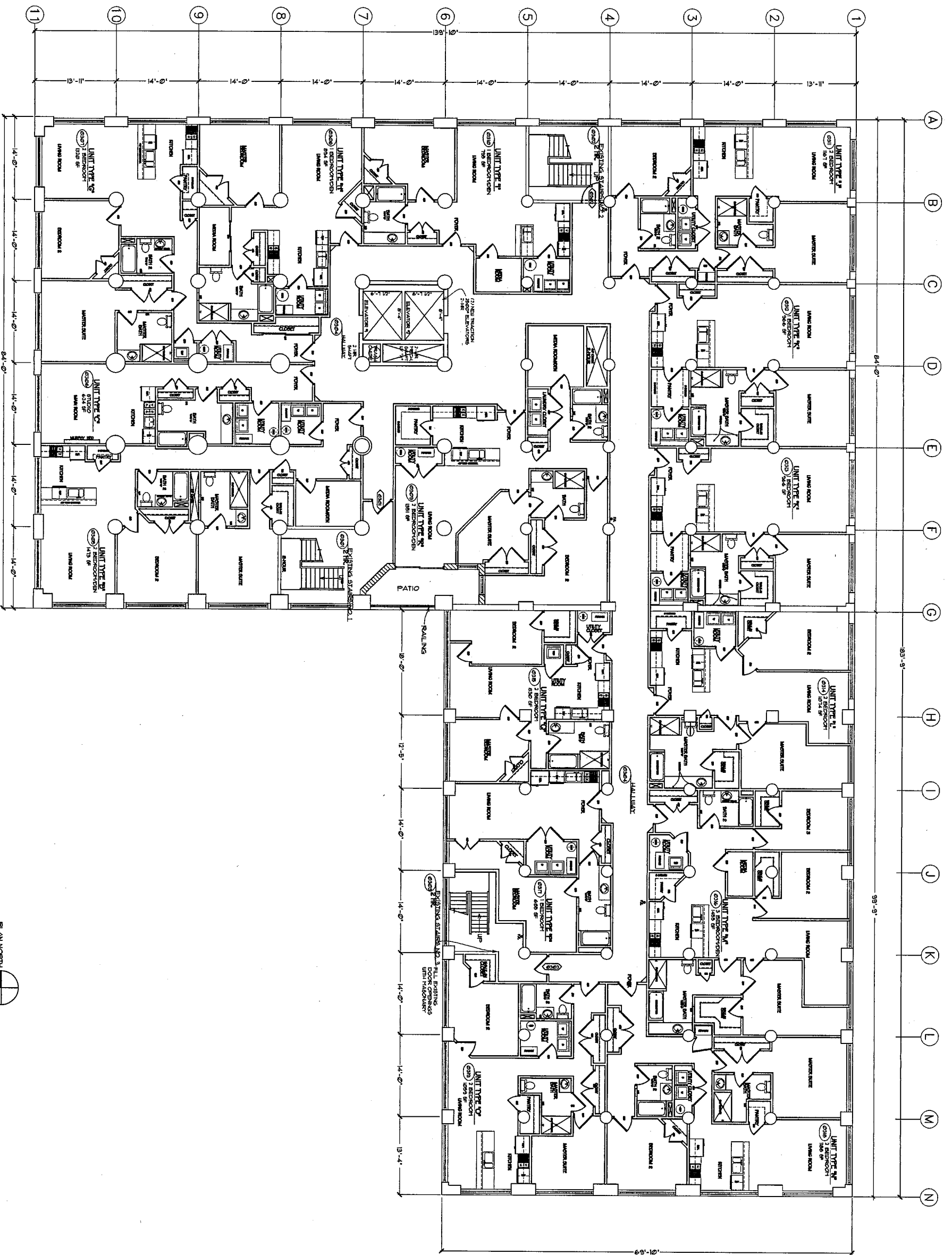

THIRD FLOOR PLAN

SCALE: 1/8" = 1'-0"
DATE ISSUED: 07/15/02

3rd Coast
Design Concepts
LLC. @2000

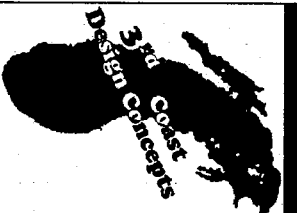

Architects and Planners
Project Title

TEWELES SEED COMPANY LOFT APARTMENTS

222 S. THIRD STREET, MILWAUKEE, WISCONSIN

Sheet Title
THIRD FLOOR
PLAN

Signature Block	Date
Owner	
Architect	
Builder	
Survey	
Proj. no.	0708
Date	07/15/02
Check by	RJS
Drawn by	BRS
Revisions	

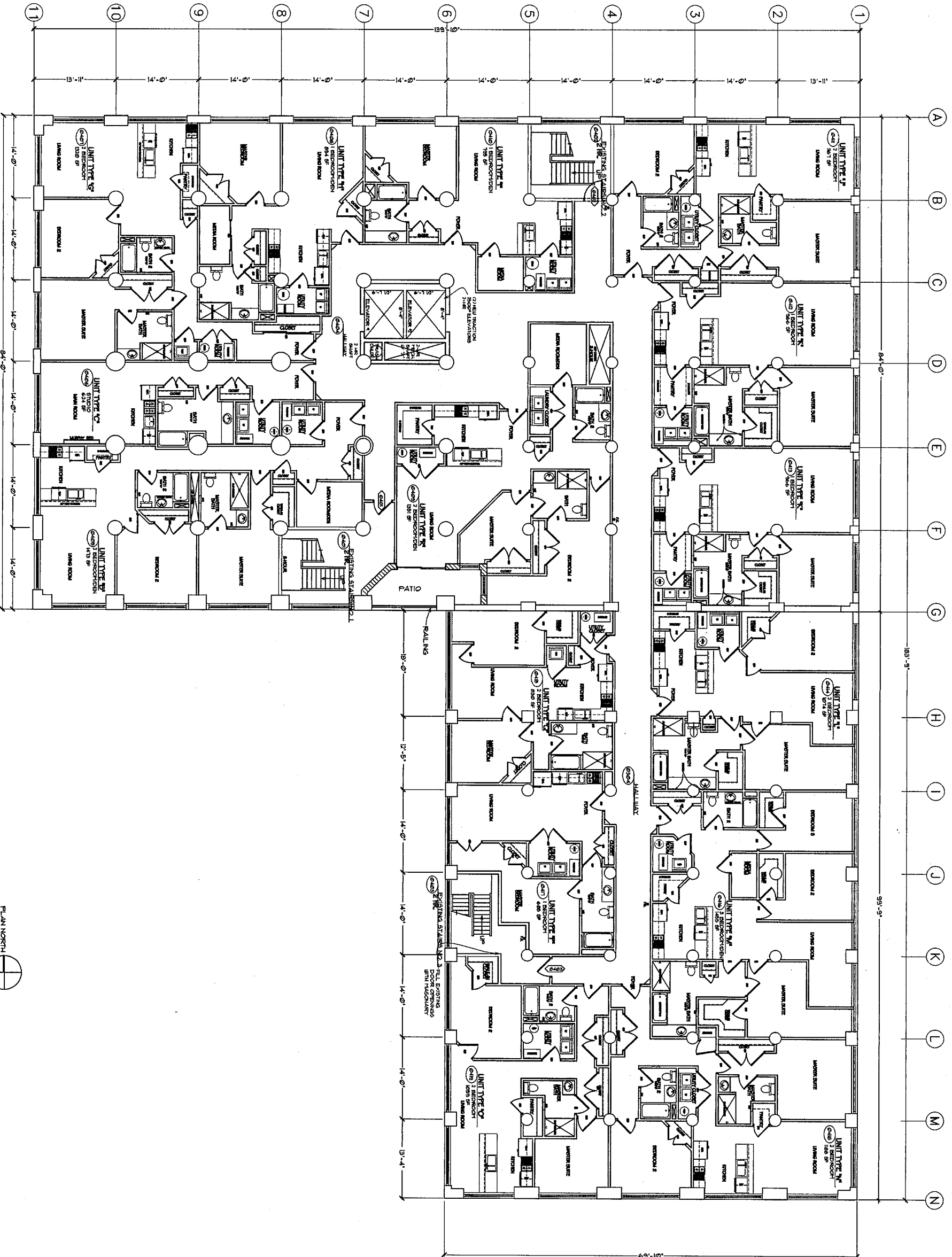

FOURTH FLOOR PLAN

SCALE: 1/8" = 1'-0"
 DATE ISSUED: 07/15/02

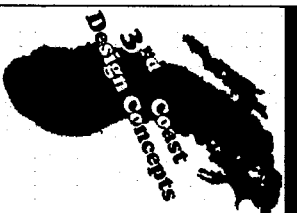

3rd Coast
 Design Concepts
 LLC. ©2000

Architects and Planners

Project Title

TEWELES SEED COMPANY LOFT APARTMENTS 222 S. THIRD STREET, MILWAUKEE, WISCONSIN

Sheet Title

FOURTH FLOOR PLAN

Signature	Brook	Date
Owner		
Architect		
Builder		
Survey		
Proj. no.	0108	Date
Drawn by	RJS	07/15/02
Check by	RJS	
Revisions		

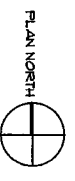
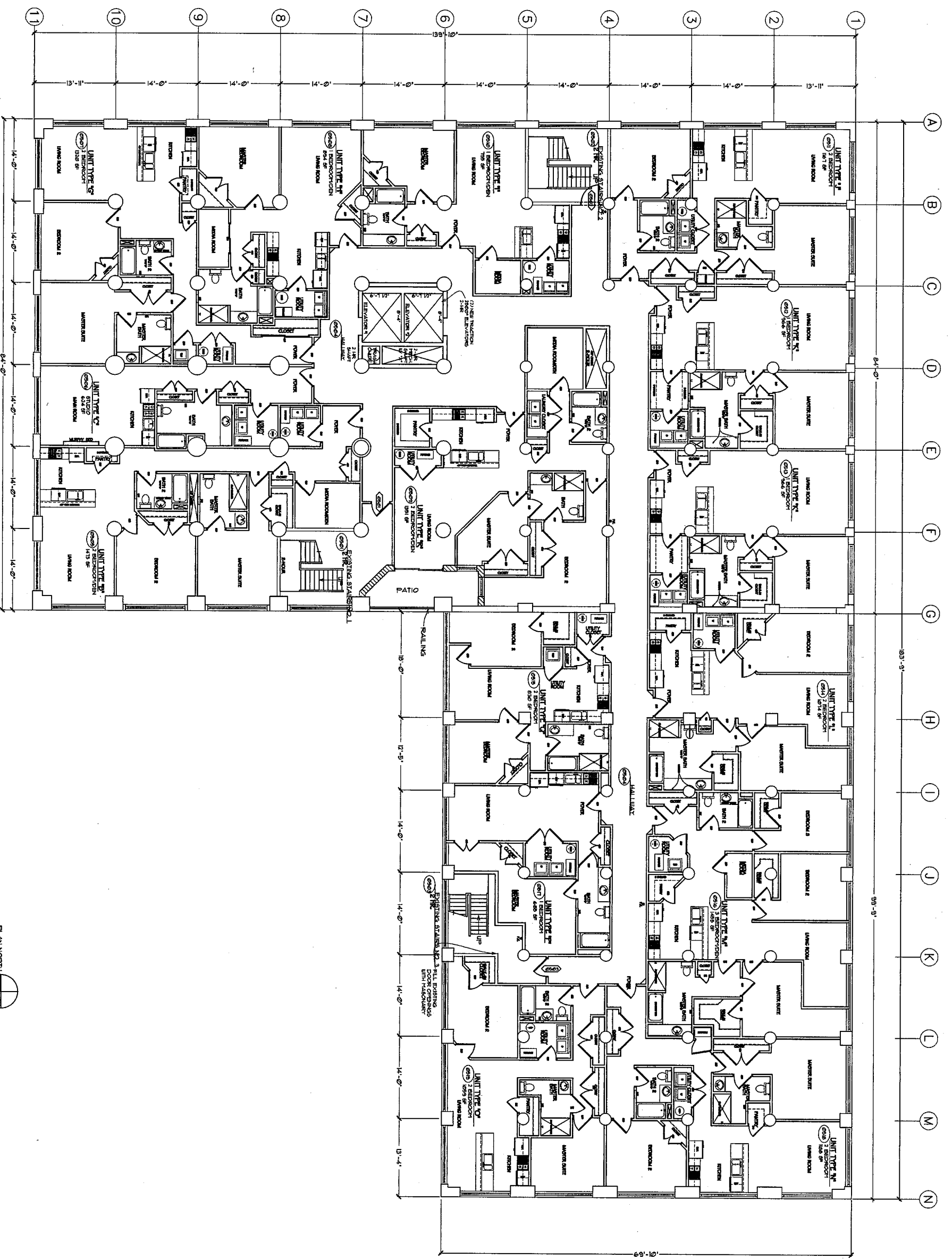

FIFTH FLOOR PLAN

SCALE: 1/8" = 1'-0"
DATE ISSUED: 07/15/02

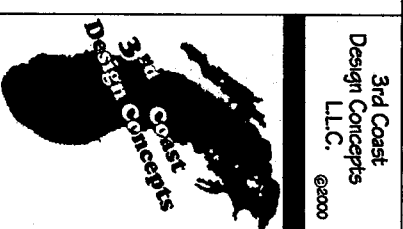

Architects and Planners
Project Title

**TEWELES SEED
COMPANY LOFT APARTMENTS**
222 S. THIRD STREET, MILWAUKEE, WISCONSIN

Sheet Title
**FIFTH FLOOR
PLAN**

Signature Block	Date
Owner	
Architect	
Builder	
Survey	
Proj. no.	0108
Date	07/15/02
Check by	RJS
Drawn by	BRS
Revisions	

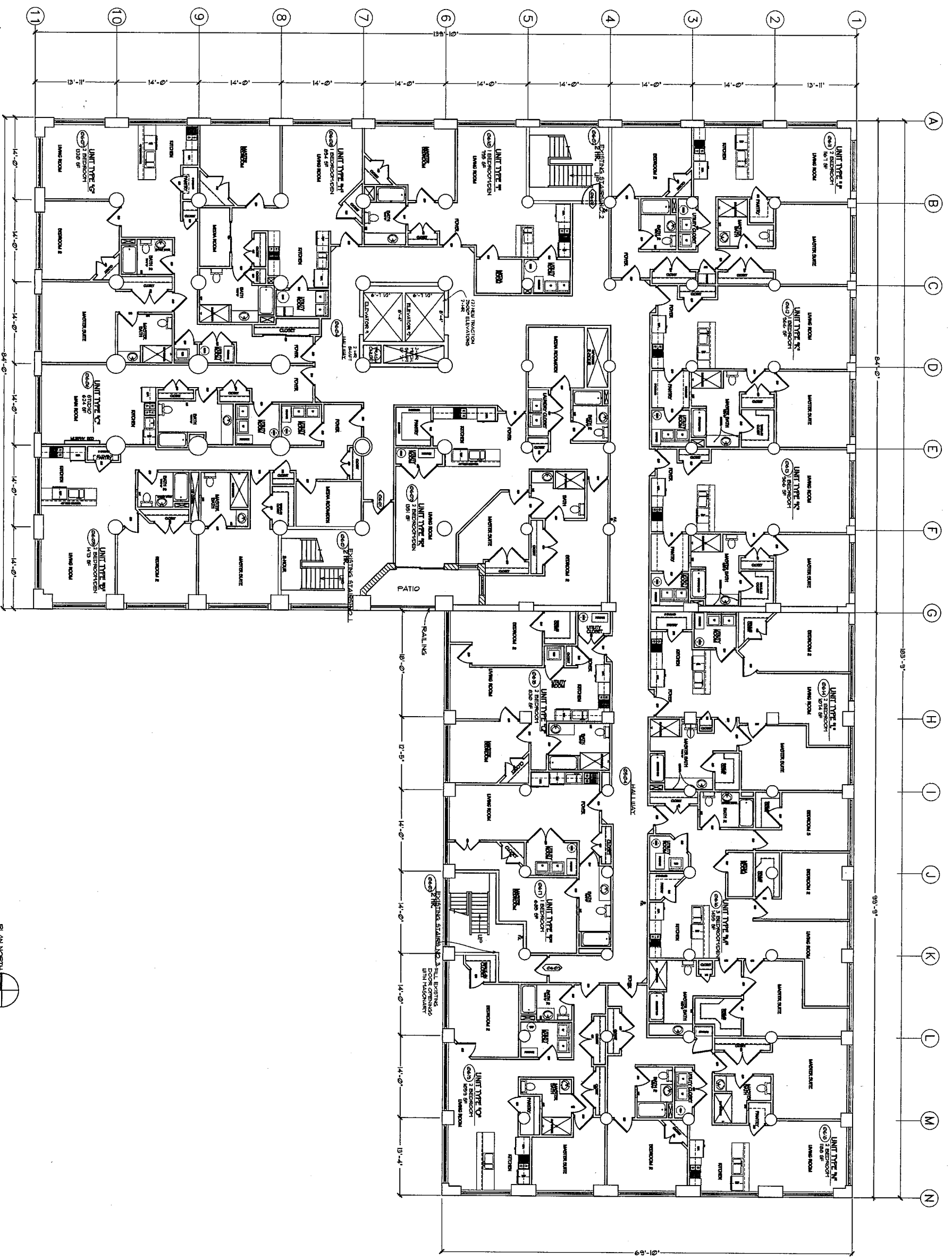

SIXTH FLOOR PLAN

SCALE: 1/8" = 1'-0"
 DATE ISSUED: 07/15/02

3rd Coast
 Design Concepts
 LLC. ©2000



Architects and Planners

Project Title

TWELES SEED COMPANY LOFT APARTMENTS 222 S. THIRD STREET, MILWAUKEE, WISCONSIN

Sheet Title
**SIXTH FLOOR
 PLAN**

Signature Block	Date
Owner	07/08
Architect	07/15/02
Builder	R/S
Survey	B/S
Prof. no.	0708
Date	07/15/02
Check by	R/S
Drawn by	B/S
Revisions	

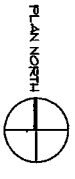
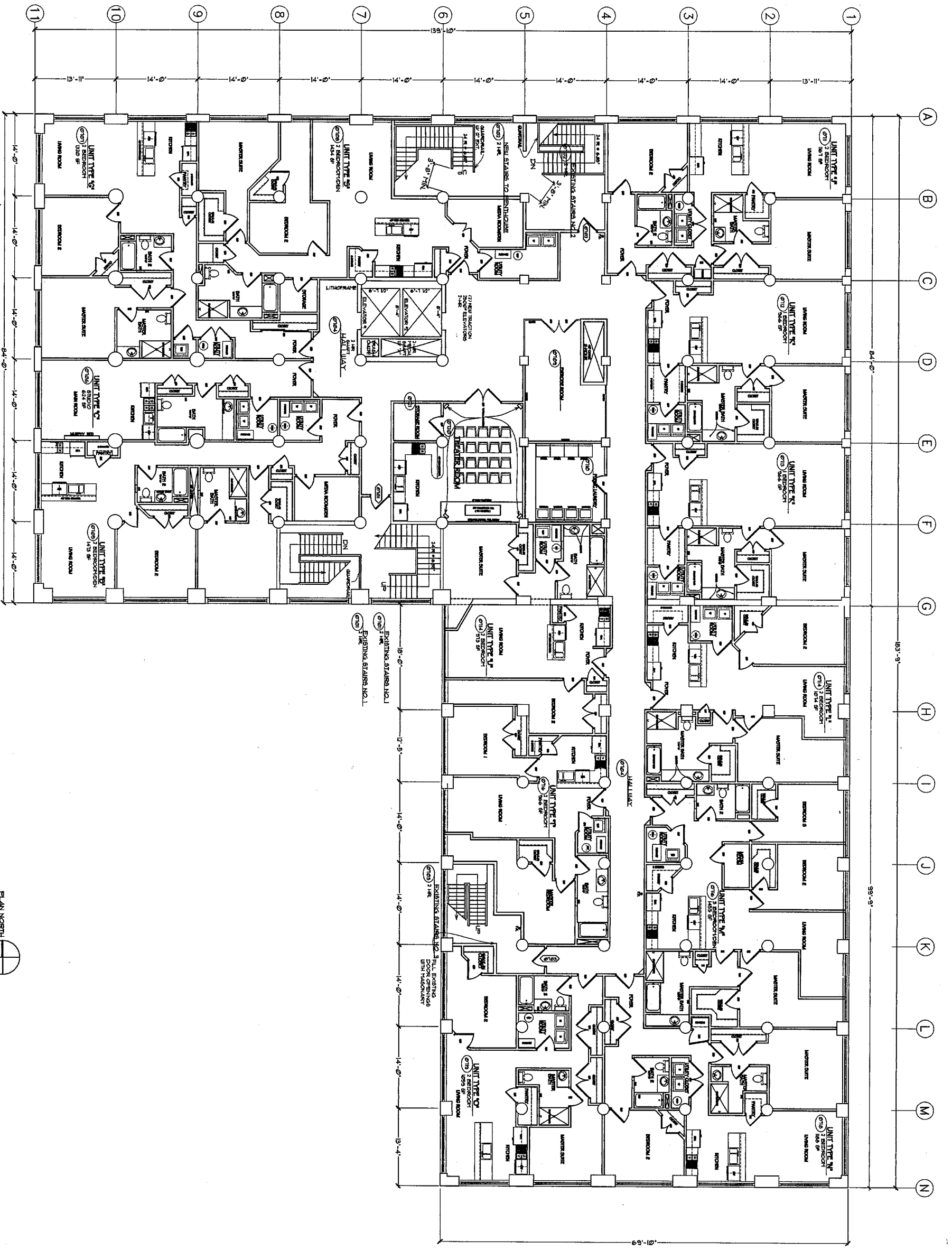

SEVENTH FLOOR PLAN

SCALE: 1/8" = 1'-0"
 DATE ISSUED: 07/15/02

3rd Coast
 Design Concepts
 L.L.C. @2000



Architects and Planners

Project Title

TEWELES SEED COMPANY LOFT APARTMENTS MILWAUKEE, WISCONSIN

SEVENTH FLOOR PLAN

Signature Block	Date
Owner	
Architect	
Builder	
Surety	
Proj. no.	07106
Date	07/15/02
Check by	M/S
Drawn by	BKS
Revisors	

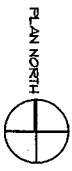
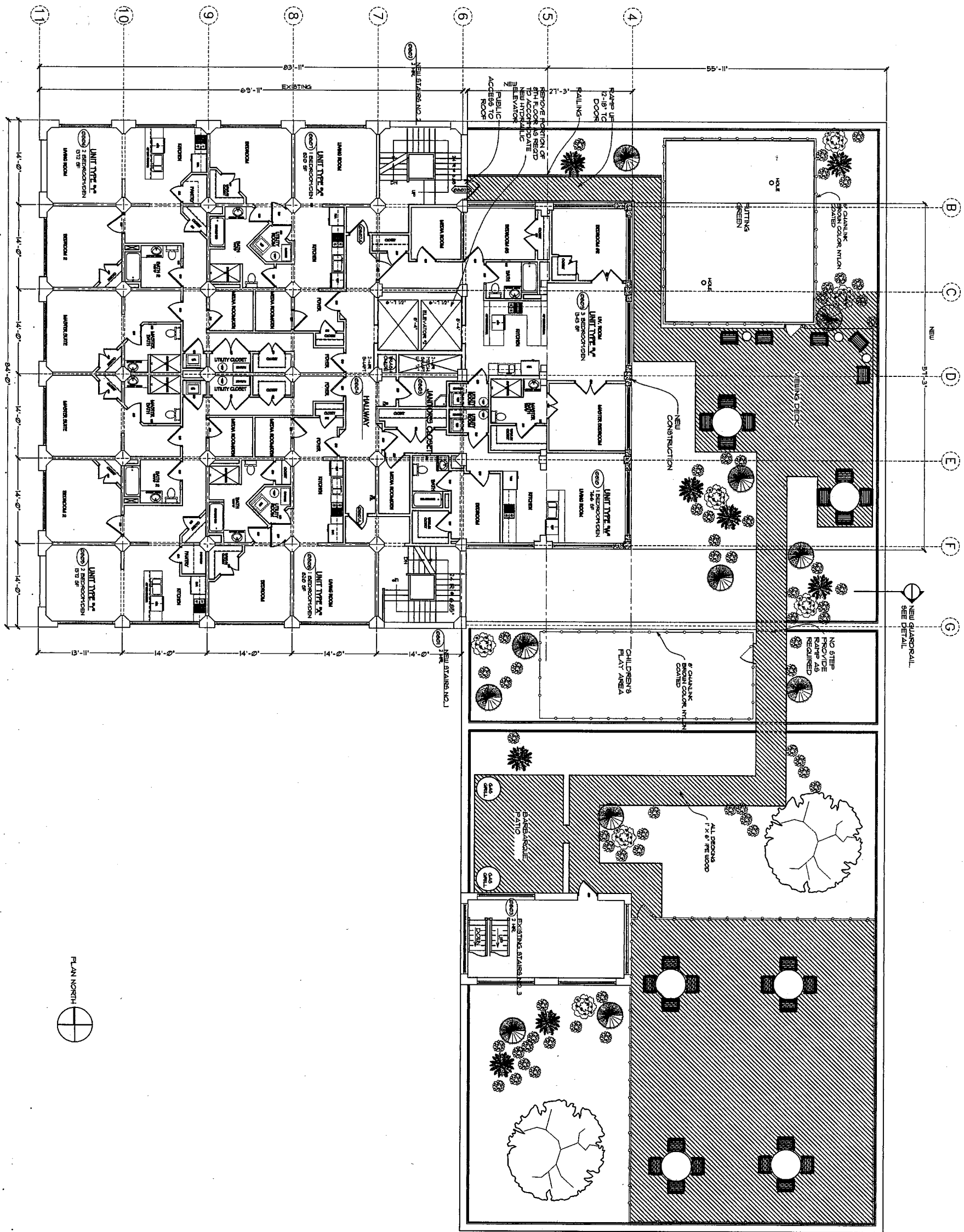

EIGHTH FLOOR PLAN

SCALE: 1/8" = 1'-0"
DATE ISSUED: 07/15/02

3rd Coast
Design Concepts
LLC. ©2000

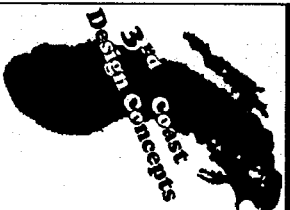

Architects and Planners

Project Title

TEWELES SEED COMPANY LOFT APARTMENTS 222 S. THIRD STREET, MILWAUKEE, WISCONSIN

Sheet Title
EIGHTH FLOOR
PLAN

Signature Block	Date
Owner	
Architect	
Builder	
Survey	
Proj. no.	0708
Date	07/15/02
Check by	RJS
Drawn by	ARSHRS
Revisions	

SHEET 11 OF 24

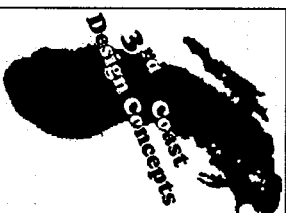

Architects and Planners

Project Title

**TWELES SEED
COMPANY LOFT APARTMENTS**
222 S. THIRD STREET, MILWAUKEE, WISCONSIN

Sheet Title
**NINTH FLOOR
PLAN**

Signature Block	Date
Owner	
Architect	
Builder	
Survey	
Proj. no.	0108
Date	07/19/02
Check by	R/S
Drawn by	AR/S/RS
Revisions	

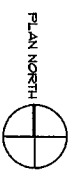
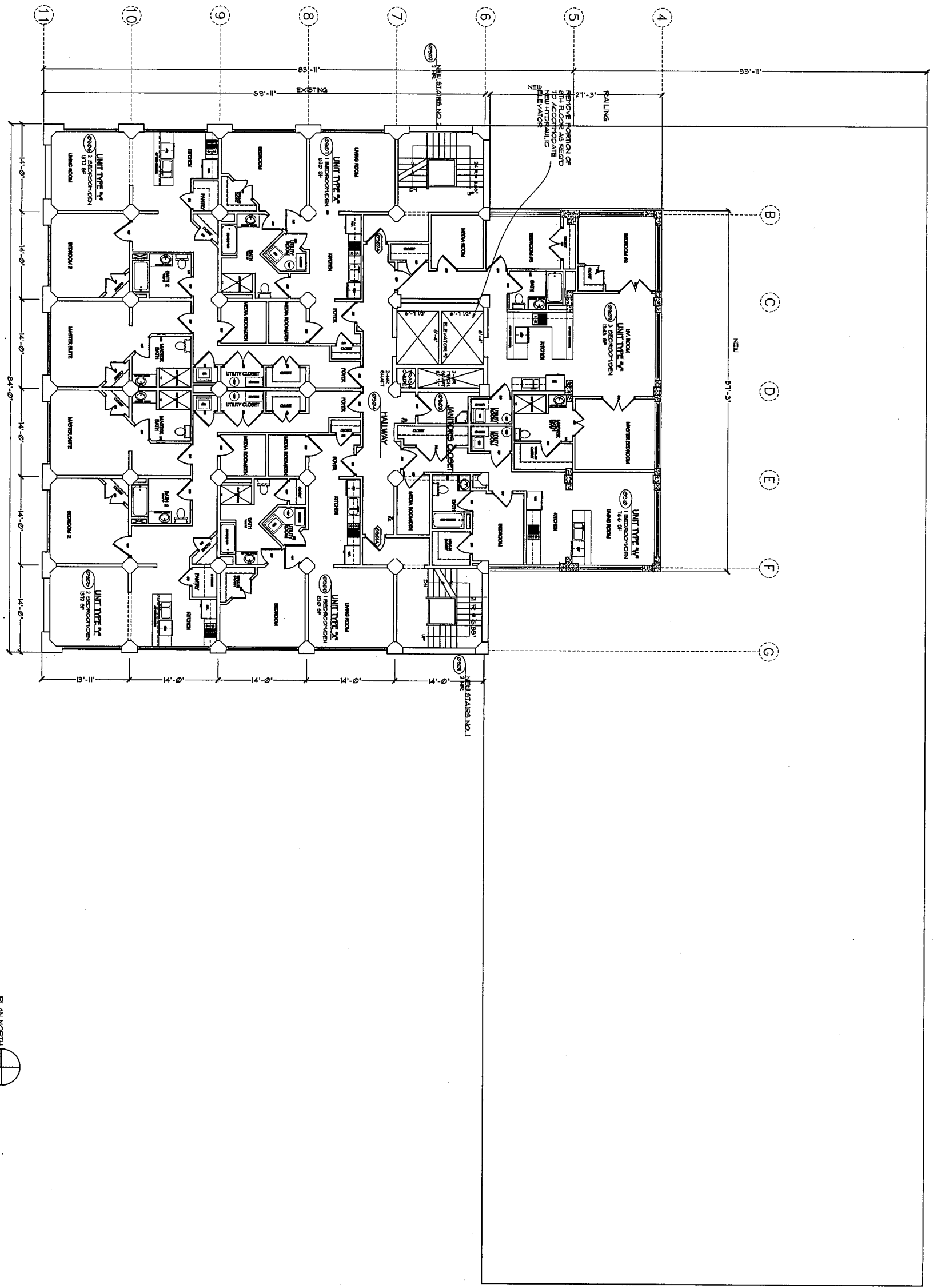

NINTH FLOOR PLAN

SCALE: 1/8" = 1'-0"
DATE ISSUED: 07/15/02

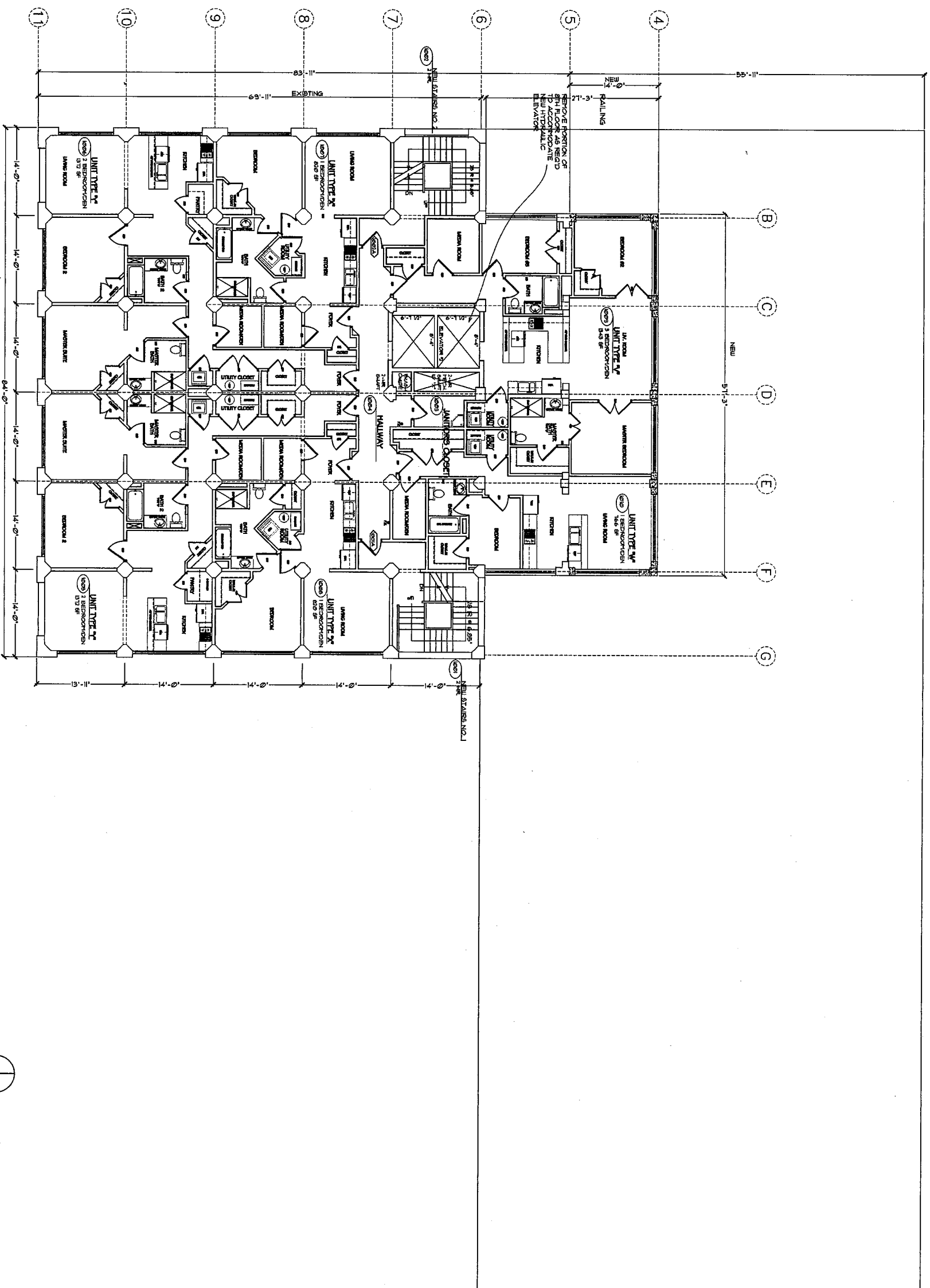

TENTH FLOOR PLAN

SCALE: 1/8" = 1'-0"
DATE ISSUED: 07/15/02

3rd Coast
Design Concepts
LLC. @2000

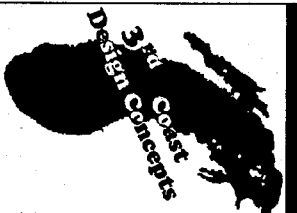

Architects and Planners
Project Title

TWELES SEED COMPANY LOFT APARTMENTS

222 S. THIRD STREET, MILWAUKEE, WISCONSIN

Sheet Title
TENTH FLOOR
PLAN

Signature Block	Date
Owner	
Architect	
Builder	
Survey	
Proj. no.	0708
Date	07/15/02
Checked by	RJS
Drawn by	ARS/BS
Revisions	



Architects and Planners

Project Title

TEWELES SEED
COMPANY LOFT APARTMENTS
222 S. THIRD STREET, MILWAUKEE, WISCONSIN

Sheet Title
ELEVENTH FLOOR
PLAN

Signature Block	Date
Owner	
Architect	
Builder	
Survey	
Proj. no.	0106
Date	07/15/02
Check by	RJS
Drawn by	ARS/RS
Revisions	

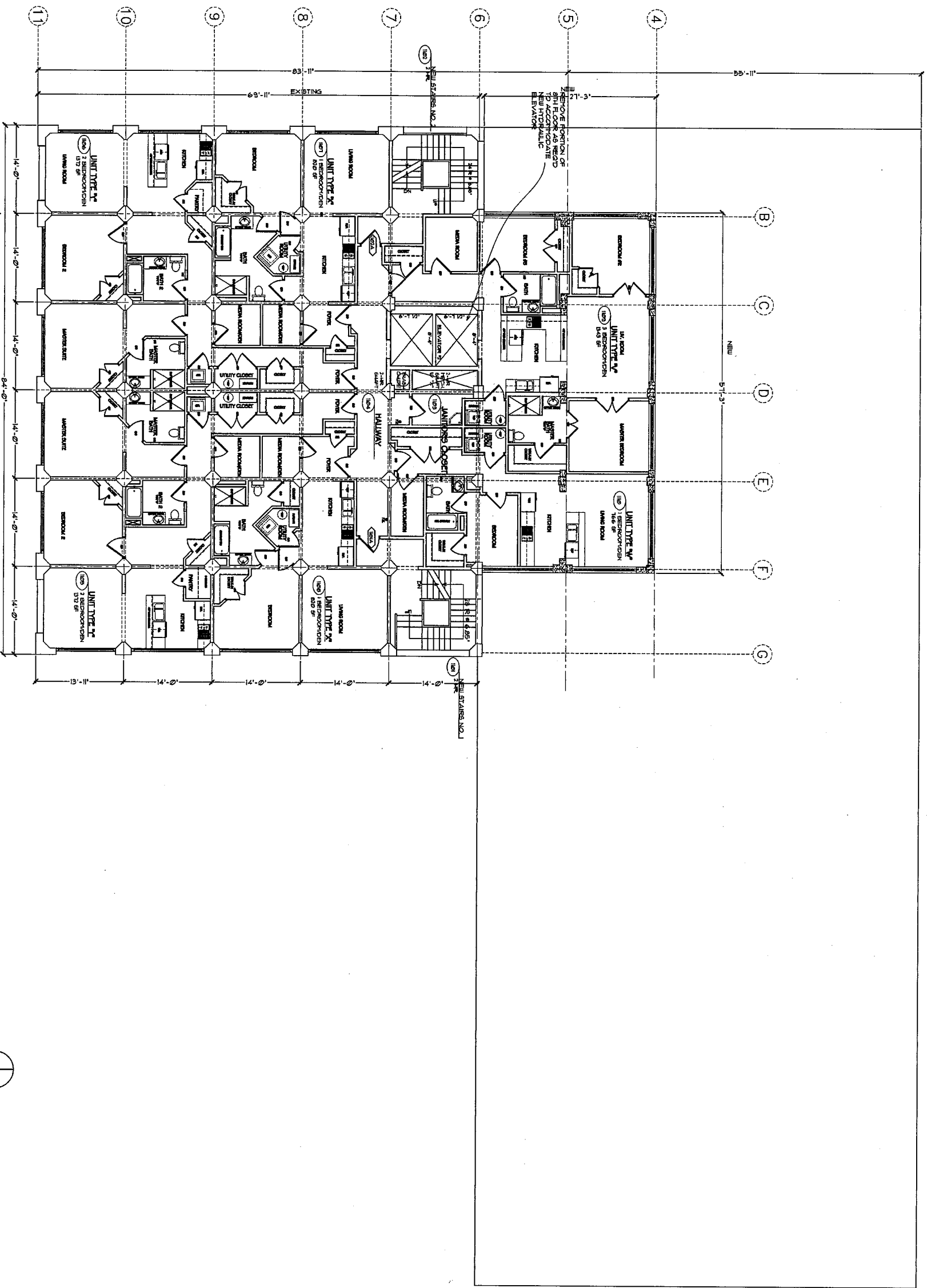

ELEVENTH FLOOR PLAN

SCALE: 1/8" = 1'-0"
DATE ISSUED: 07/15/02



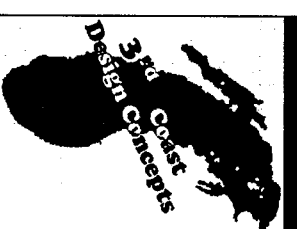

Architects and Planners

Project Title

TEWELES SEED
COMPANY LOFT APARTMENTS
222 S. THIRD STREET, MILWAUKEE, WISCONSIN

Sheet Title
TWELFTH FLOOR
PLAN

Signature Block	Date
Owner	
Architect	
Builder	
Survey	
Proj. no.	0708
Date	07/15/02
Check by	RUS
Drawn by	AKS/SRS
Revisions	

SHEET 16 OF 24

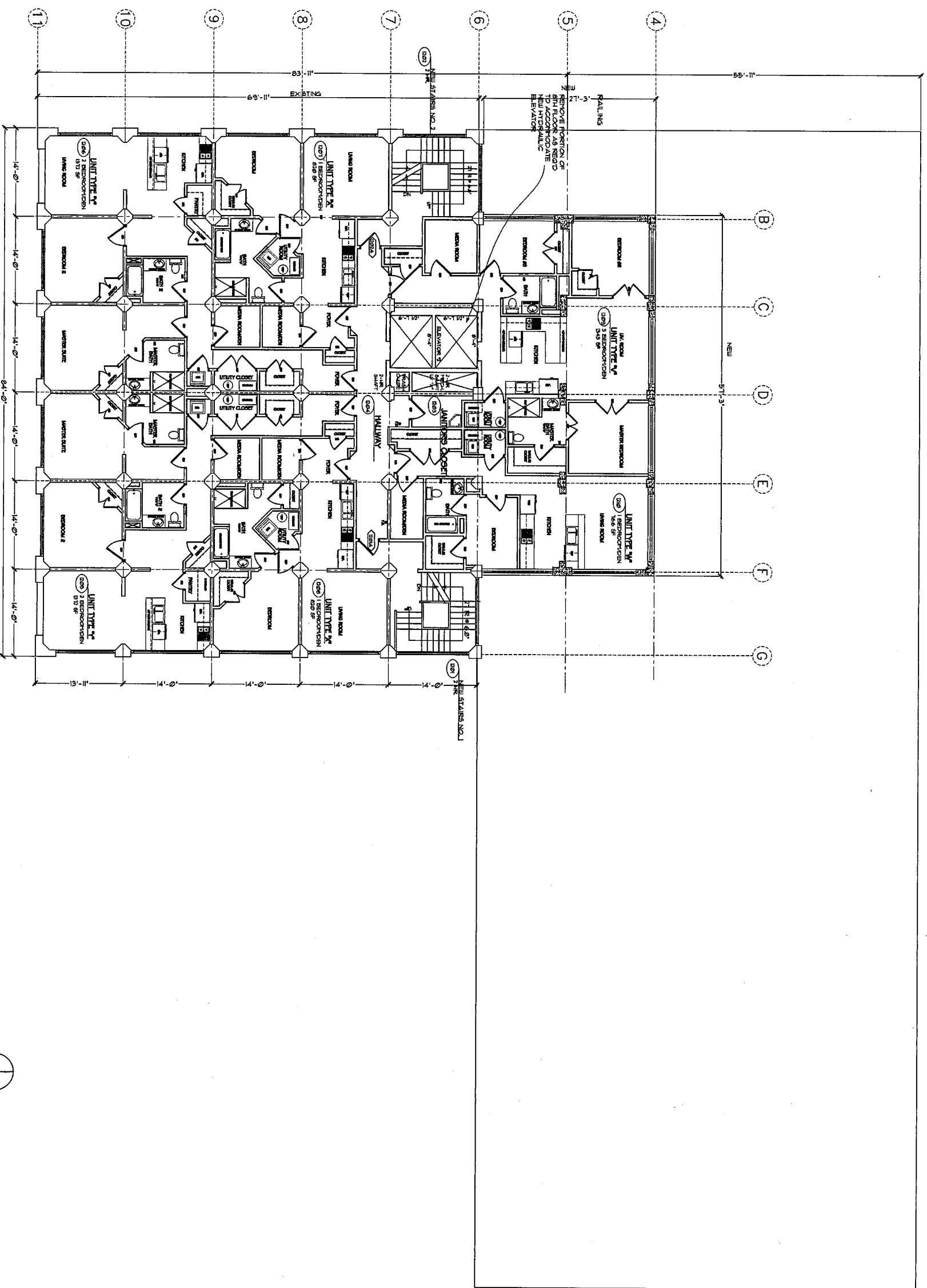

TWELFTH FLOOR PLAN

SCALE: 1/8" = 1'-0"
DATE ISSUED: 07/15/02

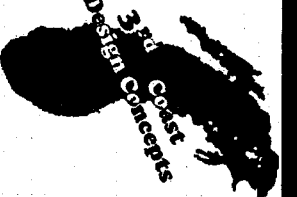

Architects and Planners

Project 7786

TEWELES SEED
COMPANY LOFT APARTMENTS
222 S. THIRD STREET, MILWAUKEE, WISCONSIN

Sheet 7786
13TH FLOOR
PENTHOUSE
PLAN

Signature Block	Date
Owner	
Architect	
Builder	
Survey	
Proj. no.	0706
Date	07/15/02
Check by	RJS
Drawn by	ARS/BRS
Revisions	

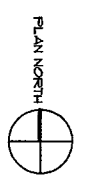
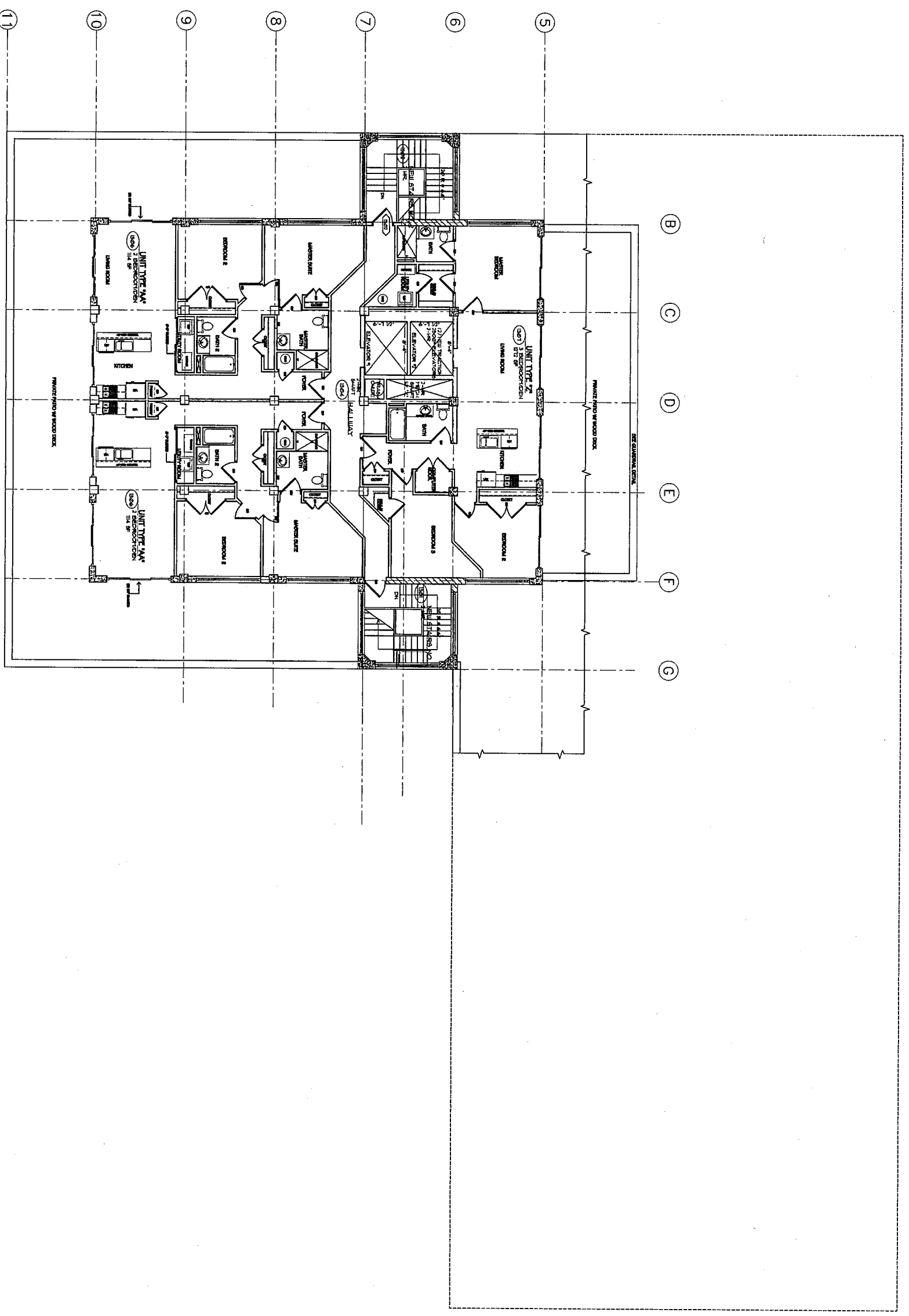

THIRTEENTH FLOOR PLAN

SCALE : 1/8" = 1'-0"
DATE ISSUED : 07/15/02

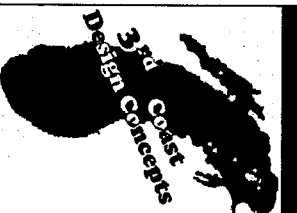

Architects and Planners

Project Title

TEWELES SEED
COMPANY LOFT APARTMENTS
222 S. THIRD STREET, MILWAUKEE, WISCONSIN

Sheet Title
14TH FLOOR
PENTHOUSE
PLAN

Signature Block	Date
Owner	
Architect	
Builder	
Survey	
Proj. no.	0706
Date	07/15/02
Check by	RS
Drawn by	ARS/BRS
Revisions	

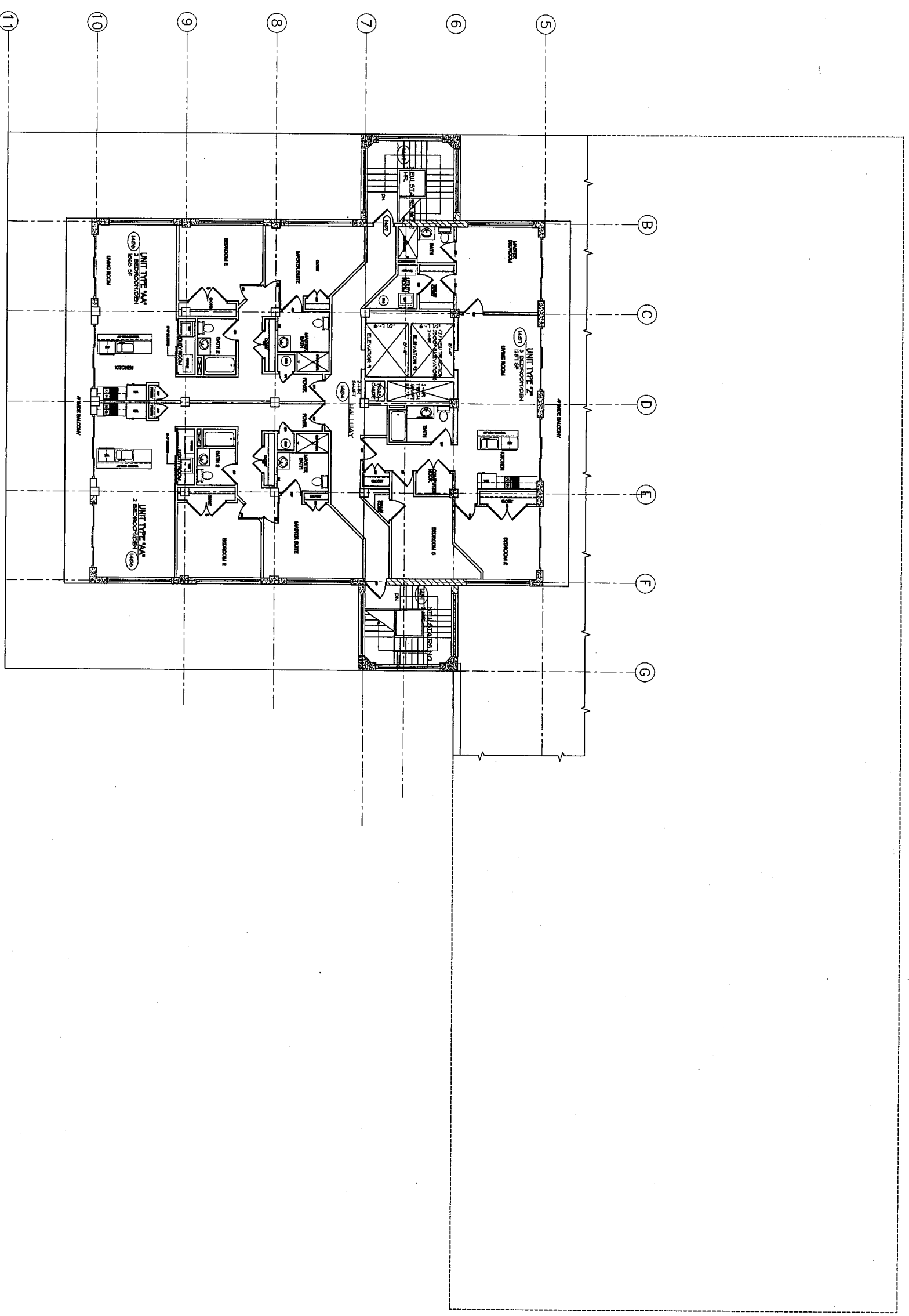

FOURTEENTH FLOOR PLAN

SCALE: 1/8" = 1'-0"
DATE ISSUED: 07/15/02

ALL SURFACE AND OPEN UNFINISHED
 EXPOSED TO WEATHER SHALL BE
 PROTECTED BY A 1/2" MIN. THICK
 RIGIDLY APPLIED CORNER OF BUILDING
 3/4" DIAMETER SOFT GLOU BRUSH 1/4"
 SIDE LIGHTS IN A HALF GLOBE
 SHAPE BY BROOK BRADSHAW TRN.

REPAIR EXISTING NEW SUBSTRATE WITH
 REPAIR AND REFINISH. REPAIR SHALL BE
 NOT OBTAINED BY NEW ELEVATOR PENITENCE
 SEE DETAIL.

TOP OF BUILDING
 EL. + 145' - 0"
 NEW STEEL BALCONY
 SEE DETAIL
 NEW ROOF/MECH FLOOR
 EL. + 17' - 0"

REPAIR EXISTING NEW SUBSTRATE WITH
 REPAIR AND REFINISH. REPAIR SHALL BE
 NOT OBTAINED BY NEW ELEVATOR PENITENCE
 SEE DETAIL.
 NEW ELEVATOR PENITENCE
 SEE DETAIL.
 PATIO DOOR IN NEW OPENING
 TYPICAL NEW WINDOW
 OPENING WITH BRICK BELOW
 NEW STEEL BALCONY
 SEE DETAIL. MAKE ADJUSTION
 TO MATCH EXISTING
 NEW QUADRANTAL 5TH FLOOR
 PRIVATE DECK SEE DETAIL.

THIRTEENTH FLOOR
 EL. + 125' - 0"

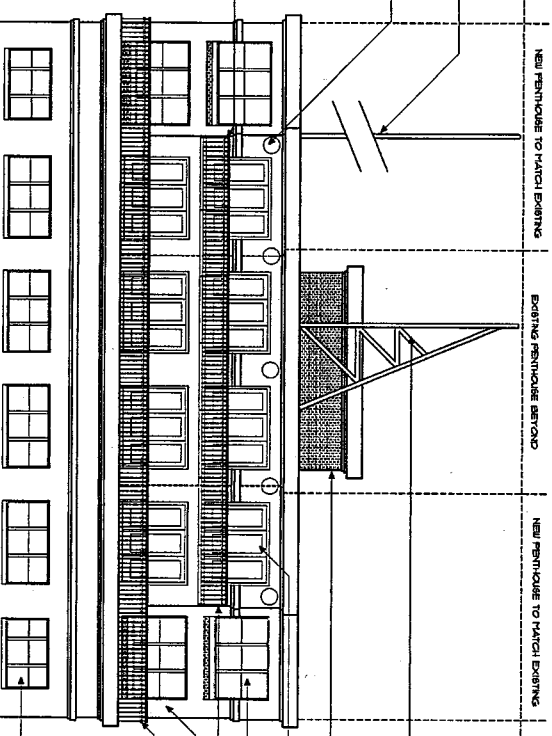

ELEVENTH FLOOR
 EL. + 107' - 0"

EXISTING WINDOW OPENING
 WITH NEW WINDOW

TENTH FLOOR
 EL. + 100' - 0"

EXISTING STAR PENITENCE
 5TH FLOOR UP

NINTH FLOOR
 EL. + 94' - 0"

REPAIR EXISTING PARAPET.
 REPAIR AND REFINISH. REPAIR SHALL BE
 NOT OBTAINED BY NEW ELEVATOR PENITENCE
 SEE DETAIL.

EIGHTH FLOOR
 EL. + 87' - 0"

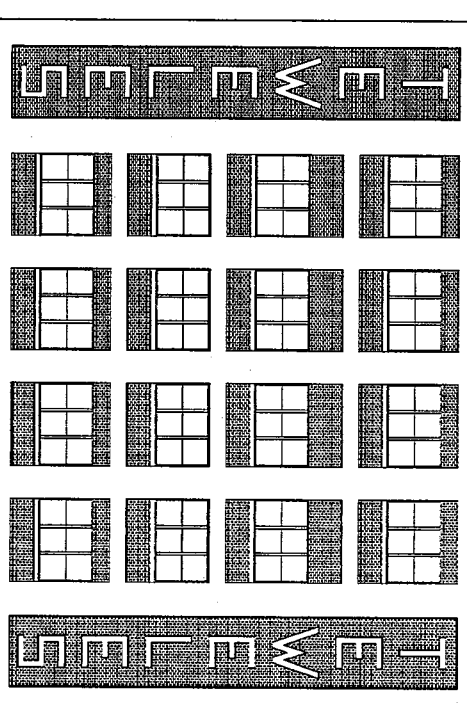

SEVENTH FLOOR
 EL. + 80' - 0"

SIXTH FLOOR
 EL. + 74' - 0"

FIFTH FLOOR
 EL. + 67' - 0"

FOURTH FLOOR
 EL. + 60' - 0"

THIRD FLOOR
 EL. + 53' - 0"

SECOND FLOOR
 EL. + 46' - 0"

FIRST FLOOR
 EL. + 4' - 0"

GROUND ELEVATION

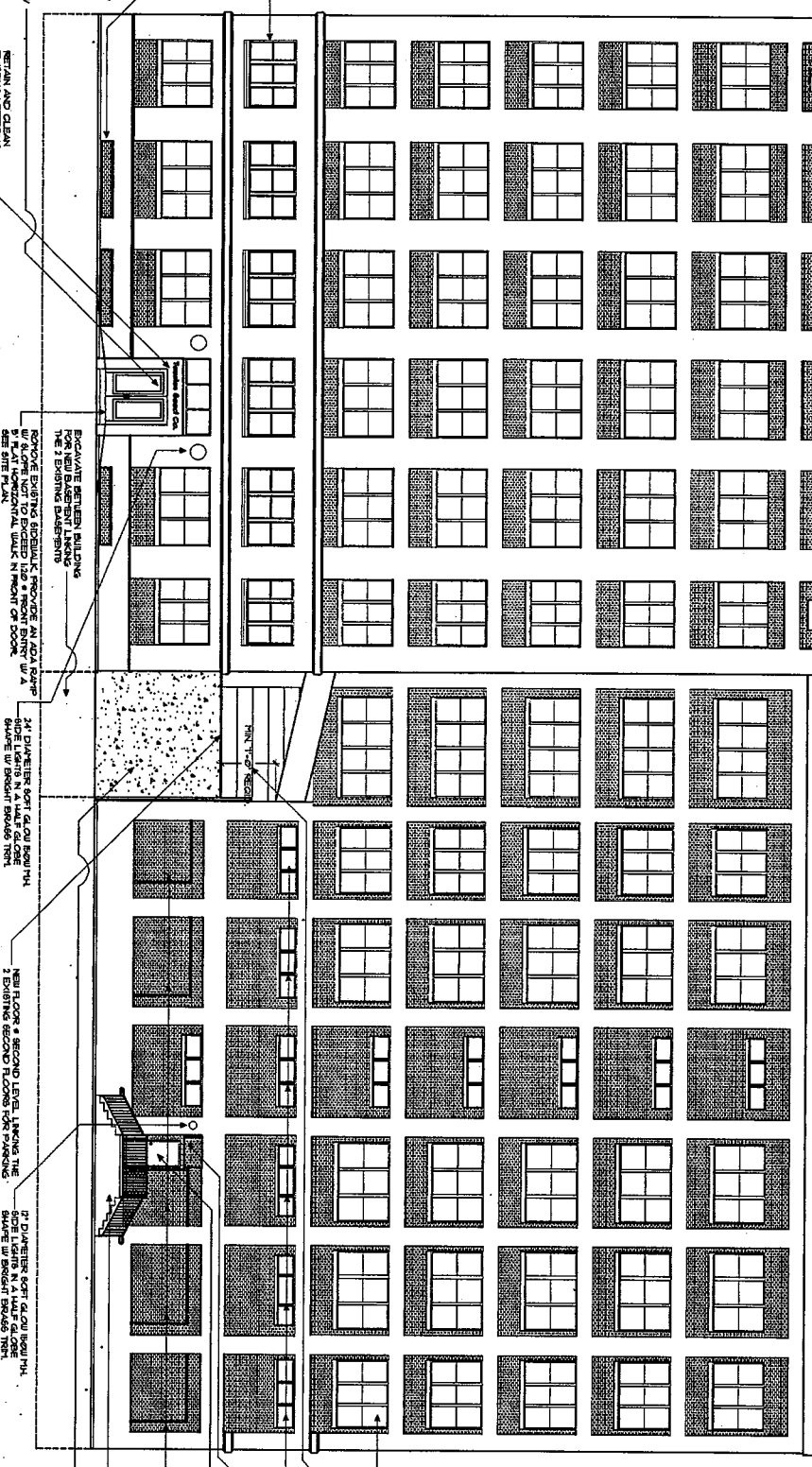

TYPICAL REPAIR EXISTING WINDOW
 OPENING FOR NEW WINDOW & SILL
 KEEP EXISTING HEAD OPENING
 NEW 1/2" CLEARANCE
 REQUIRED & EXISTING BRUSH
 FINISH OPENING
 BRICK OVER NEW DOOR
 REMOVE EXISTING DOOR. REMOVE 1" METAL
 PANEL. ABOVE SETBACK WITH NEW BRICK
 FROM FINISH OF ANTI-CORROSION
 REMOVE EXISTING WALL TO MATCH ADJACENT BRICK.
 REMOVE EXISTING WALL TO
 MATCH EXISTING BRICK
 KEEP EXISTING STAIRS AND
 ADD NEW CONCRETE STAIRS
 NEW BALANCE. SEE DETAIL.
 NEW RAMP UP TO SECOND FLOOR
 WITH QUADRANTAL. SEE DETAIL.

WEST ELEVATION

SCALE: 3/32" = 1'-0"
 DATE ISSUED: 07/15/02

3rd Coast
 Design Concepts
 LLC. ©2000

TEWELES SEED COMPANY LOFT APARTMENTS

222 S. THIRD STREET, MILWAUKEE, WISCONSIN

Project Title	WEST ELEVATION
Signature Block	Date
Owner	
Architect	
Builder	
Survey	
Proj. no.	0106
Date	07/15/02
Check By	RJS
Drawn By	ARS
Revisors	

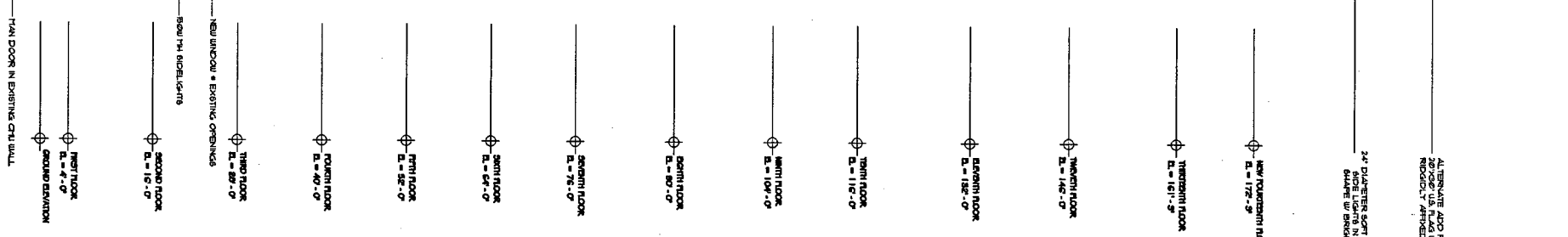
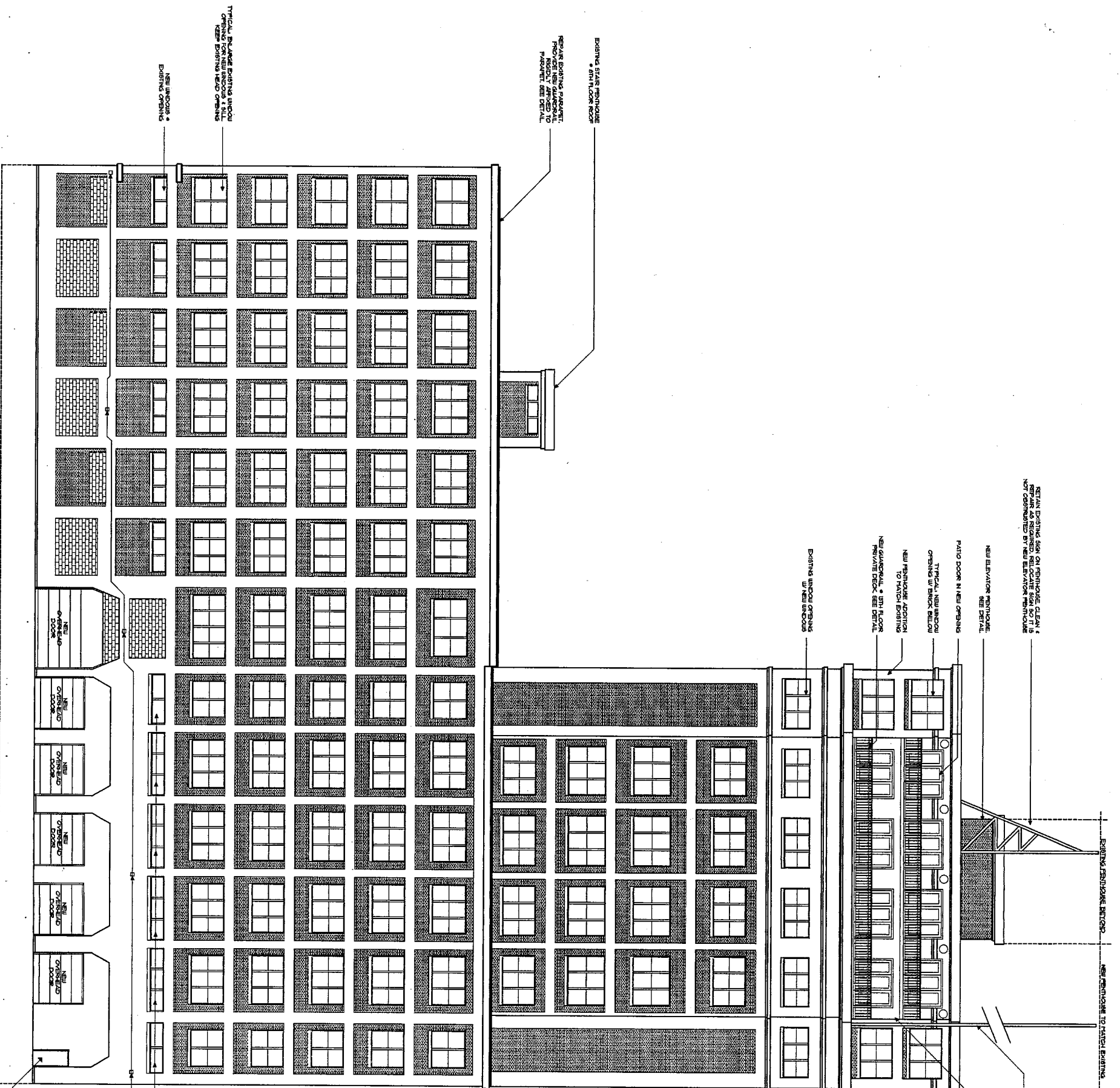

EAST ELEVATION

SCALE : 3/32" = 1'-0"
 DATE ISSUED : 07/15/02

3rd Coast
 Design Concepts
 LLC. @2000

Architects and Planners
 Project 778

**TWELES SEED
 COMPANY LOFT APARTMENTS**
 222 S. THIRD STREET, MILWAUKEE, WISCONSIN

Sheet Title	EAST ELEVATION		
Signature Block	Date		
Owner			
Architect			
Builder			
Survey			
Proj. no.	0708		
Drawn by	RJS		
Checked by	RJS		
Drawn by	RJS		
Revisions			



- ⊕ E. = 104'-0"
- ⊕ NEW FOURTH FLOOR E. = 172'-0"
- ⊕ NEW PERIMETER ADDITION TO MATCH EXISTING NEW STEEL BALCONY PATIO DOOR IN NEW OPENING
- ⊕ THIRTEENTH FLOOR E. = 151'-0"
- ⊕ TWELFTH FLOOR E. = 146'-0"
- ⊕ ELEVENTH FLOOR E. = 132'-0"
- ⊕ TENTH FLOOR E. = 116'-0"
- ⊕ NINTH FLOOR E. = 104'-0"
- ⊕ EIGHTH FLOOR E. = 90'-0"
- ⊕ SEVENTH FLOOR E. = 76'-0"
- ⊕ SIXTH FLOOR E. = 64'-0"
- ⊕ FIFTH FLOOR E. = 50'-0"
- ⊕ FOURTH FLOOR E. = 40'-0"
- ⊕ THIRD FLOOR E. = 29'-0"
- ⊕ SECOND FLOOR E. = 16'-0"
- ⊕ FIRST FLOOR E. = 4'-0"
- ⊕ SECOND ELEVATION

NORTH ELEVATION

SCALE : 3/32" = 1'-0"
 DATE ISSUED : 07/15/02

3rd Coast
 Design Concepts
 LLC. @2000

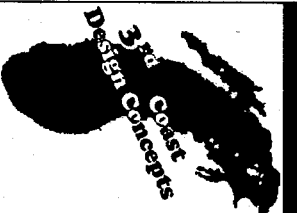

Architects and Planners
 Project Title

**TWELES SEED
 COMPANY LOFT APARTMENTS**
 222 S. THIRD STREET, MILWAUKEE, WISCONSIN

Sheet Title
**NORTH
 ELEVATION**

Signature Block	Date
Owner	
Architect	
Builder	
Surety	
Proj. No.	0108
Date	07/15/02
Check by	RUS
Drawn by	ASS
Revisions	

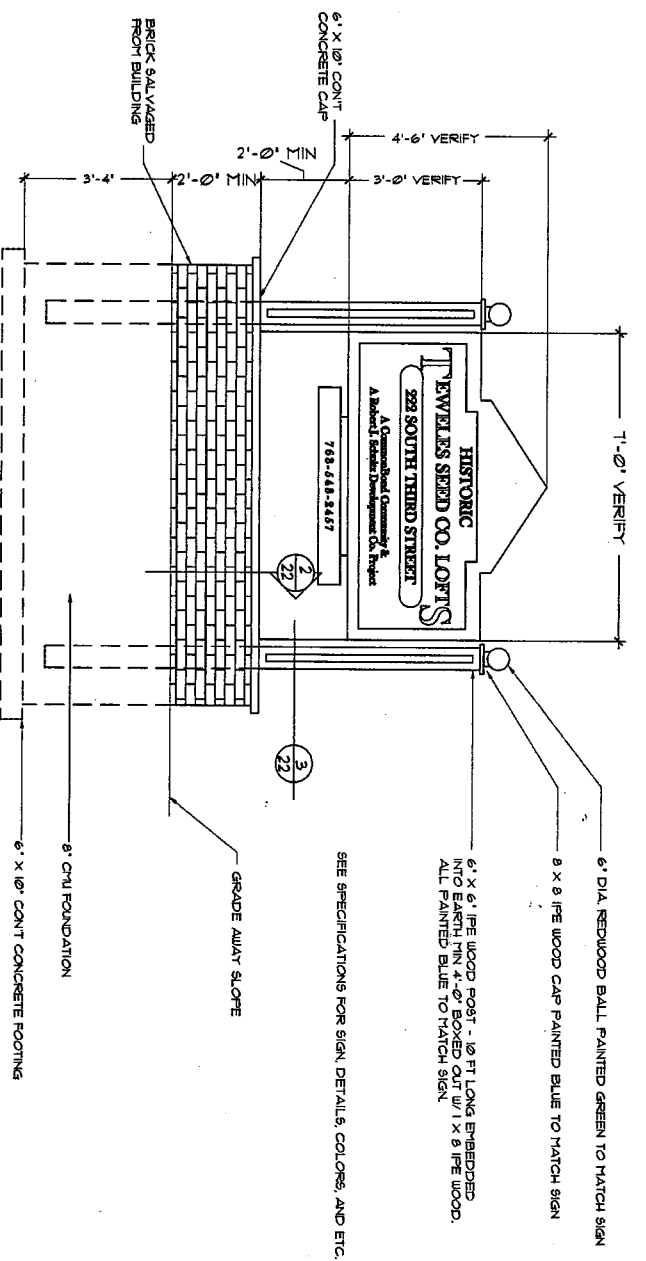

1 GROUND MOUNT SIGN
1/2" = 1'-0"

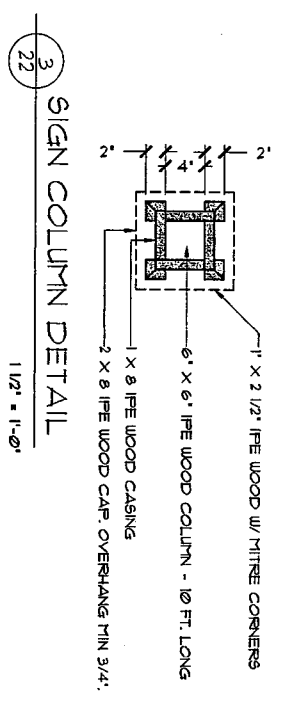

3 SIGN COLUMN DETAIL
1 1/2" = 1'-0"

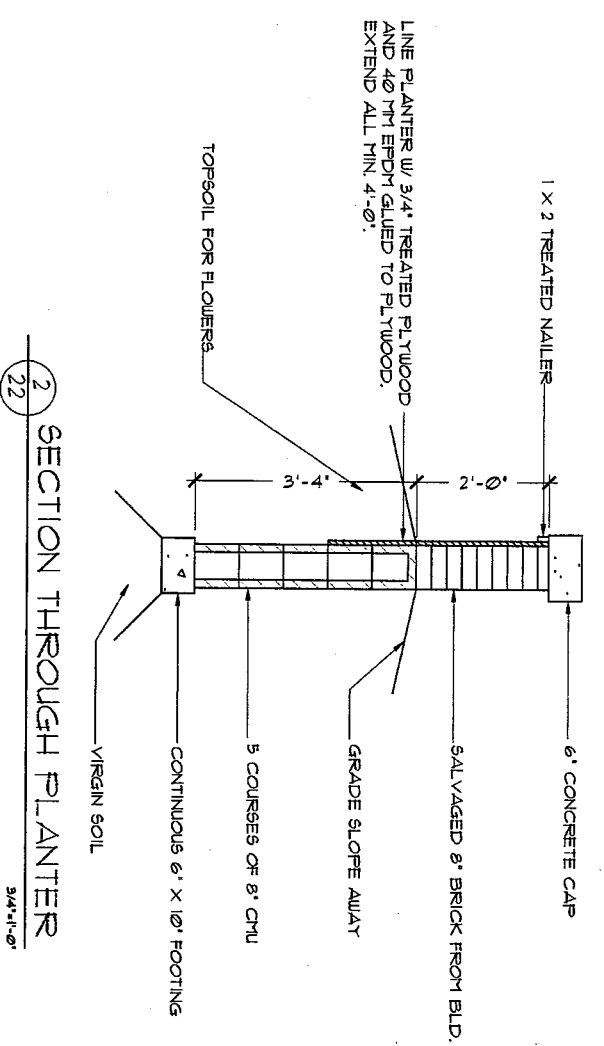

2 SECTION THROUGH PLANTER
3/4" = 1'-0"

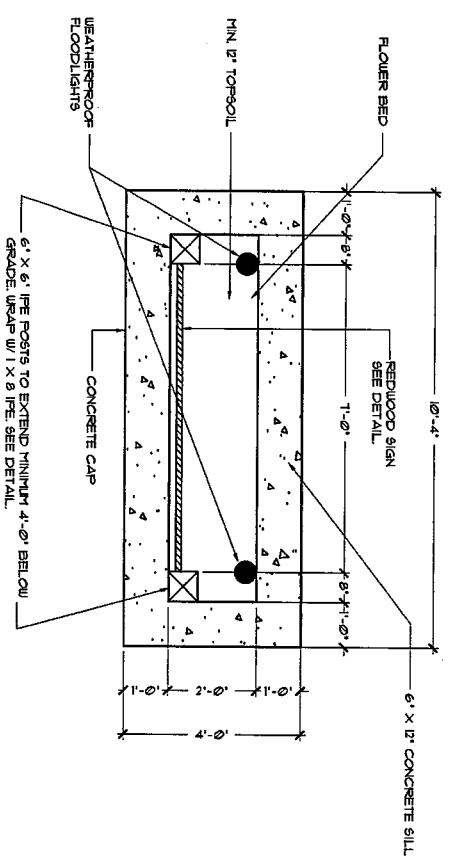

4 PLAN OF GROUND MOUNT SIGN
1/2" = 1'-0"

EXTERIOR DETAILS

SCALE: 1/2" = 1'-0"
DATE ISSUED: 07/15/02

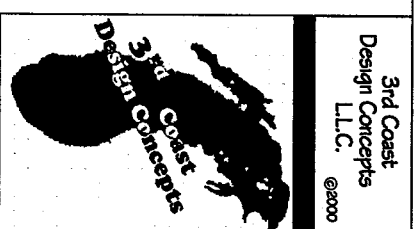

Architects and Planners
Project Title

TEWELES SEED
COMPANY LOFT APARTMENTS
222 S. THIRD STREET, MILWAUKEE, WISCONSIN

Sheet Title
EXTERIOR
DETAILS

Signature Block	Date
Owner	
Architect	
Builder	
Survey	
Proj. no.	0108
Date	07/15/02
Check by	RJS
Drawn by	BRS
Revisions	



Architects and Planners

Project Title

**TWELES SEED
COMPANY LOFT APARTMENTS**
222 S. THIRD STREET, MILWAUKEE, WISCONSIN

Sheet Title
**EXTERIOR
DETAILS**

Signature Block	Date
Owner	
Architect	
Builder	
Survey	
Proj. no.	0108
Date	07/15/02
Check by	RJS
Drawn by	RJS
Revisions	

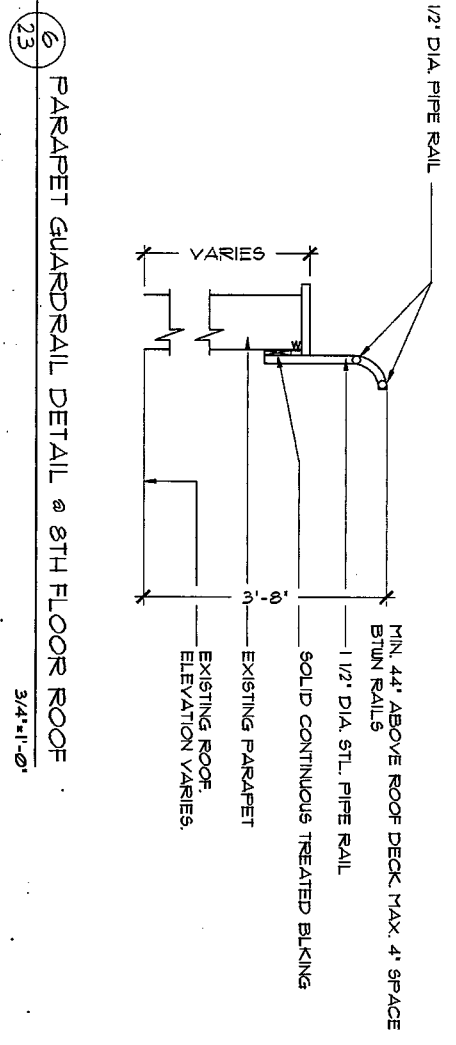
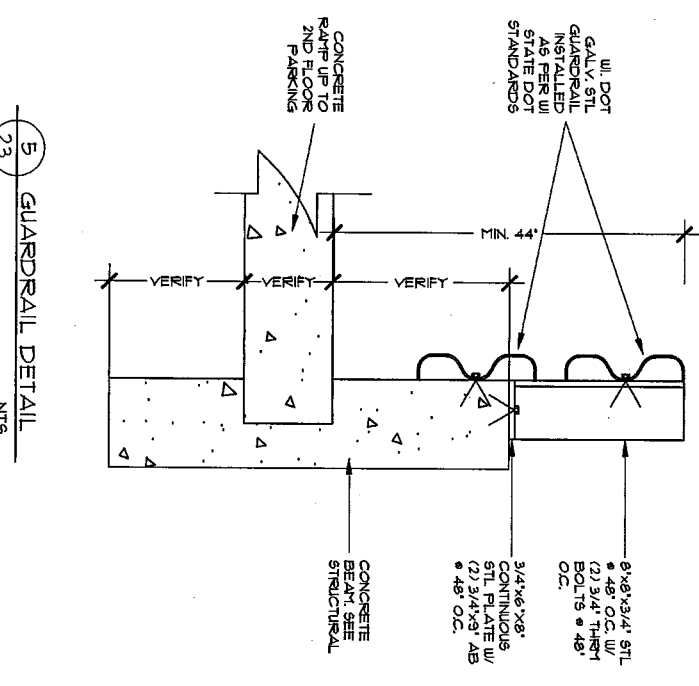
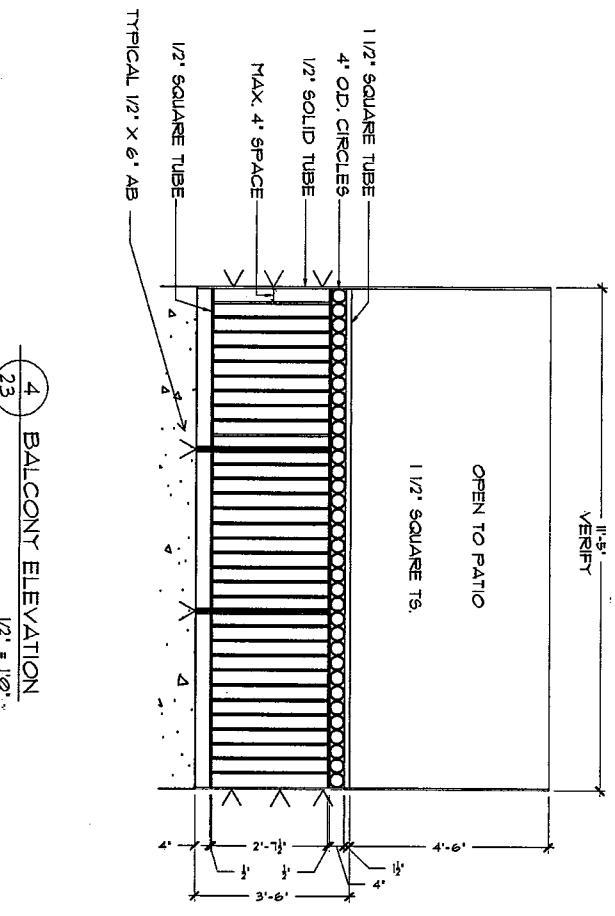
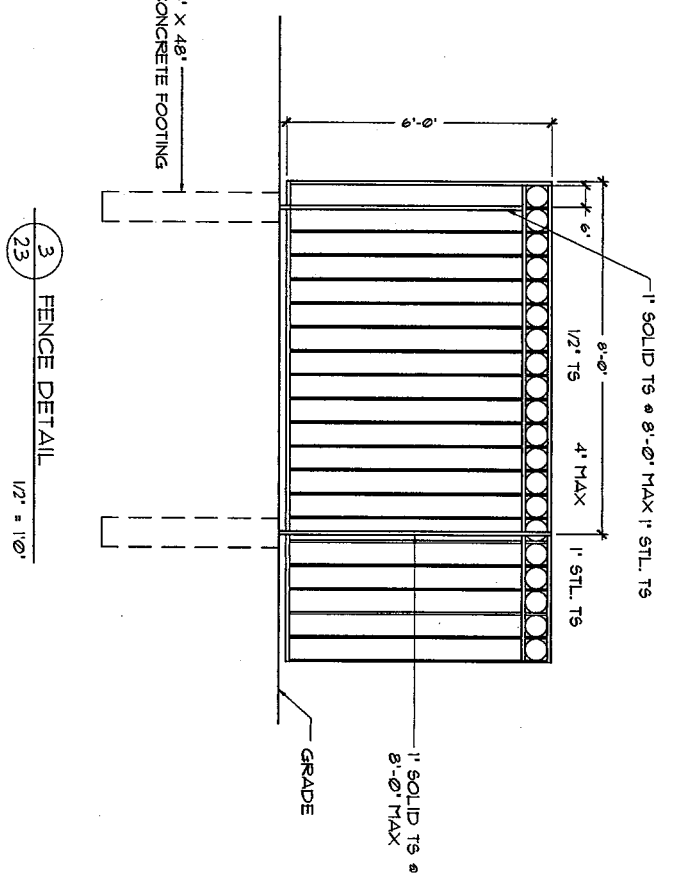
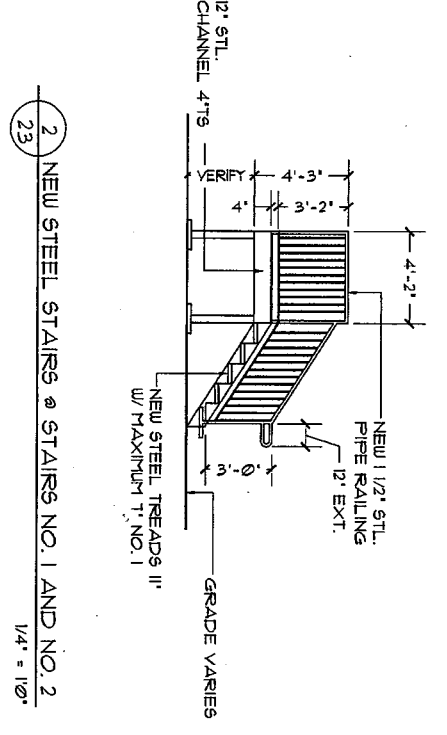
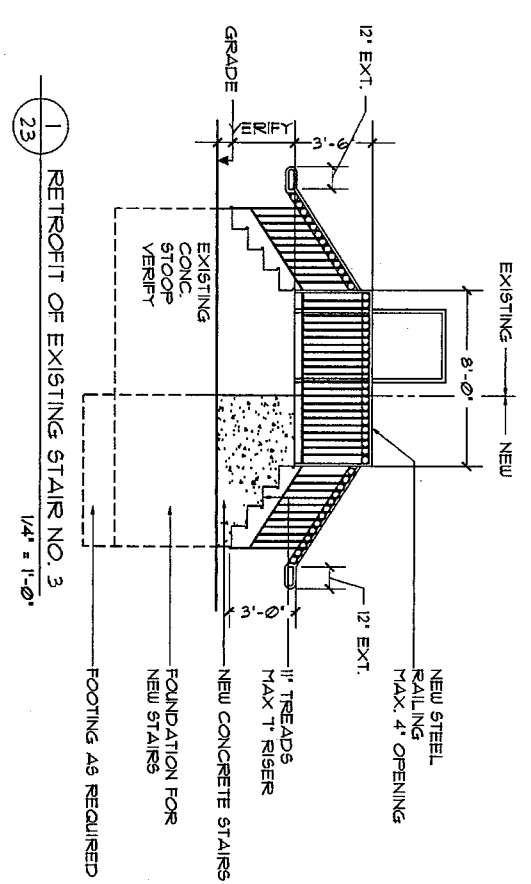

EXTERIOR DETAILS

SCALE: 1/2" = 1'-0"
DATE ISSUED: 07/15/02



Architects and Planners

Project Title

TEWELES SEED
COMPANY LOFT APARTMENTS
222 S. THIRD STREET, MILWAUKEE, WISCONSIN

Sheet Title
ALTERNATE
EIGHTH FLOOR
PLAN

Signature Block	Date
Owner	
Architect	
Builder	
Surety	
Proj. no.	0106
Date	07/15/02
Check by	RLS
Drawn by	ARF
Revisions	

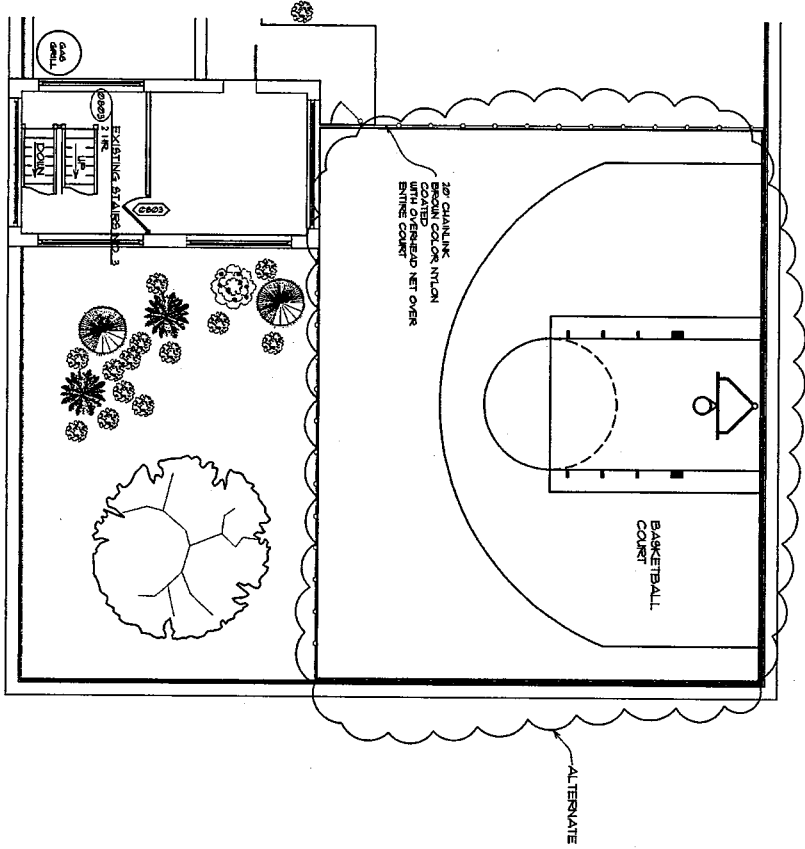

ALTERNATE ROOF TOP BASKETBALL COURT PLAN

SCALE: 1/8" = 1'-0"
DATE ISSUED: 07/15/2002

TEWELES SEED
COMPANY LOFT APARTMENTS
222 S. THIRD STREET, MILWAUKEE, WISCONSIN

Sheet Title

SECTION
THRU
RAMPS

Signature Block _____ Date _____
Owner _____
Architect _____
Builder _____
Surety _____

Proj. no. 0108
Date 07/25/02
Check by RJS
Drawn by BRS
Revisions

SHEET 3 OF 4

3

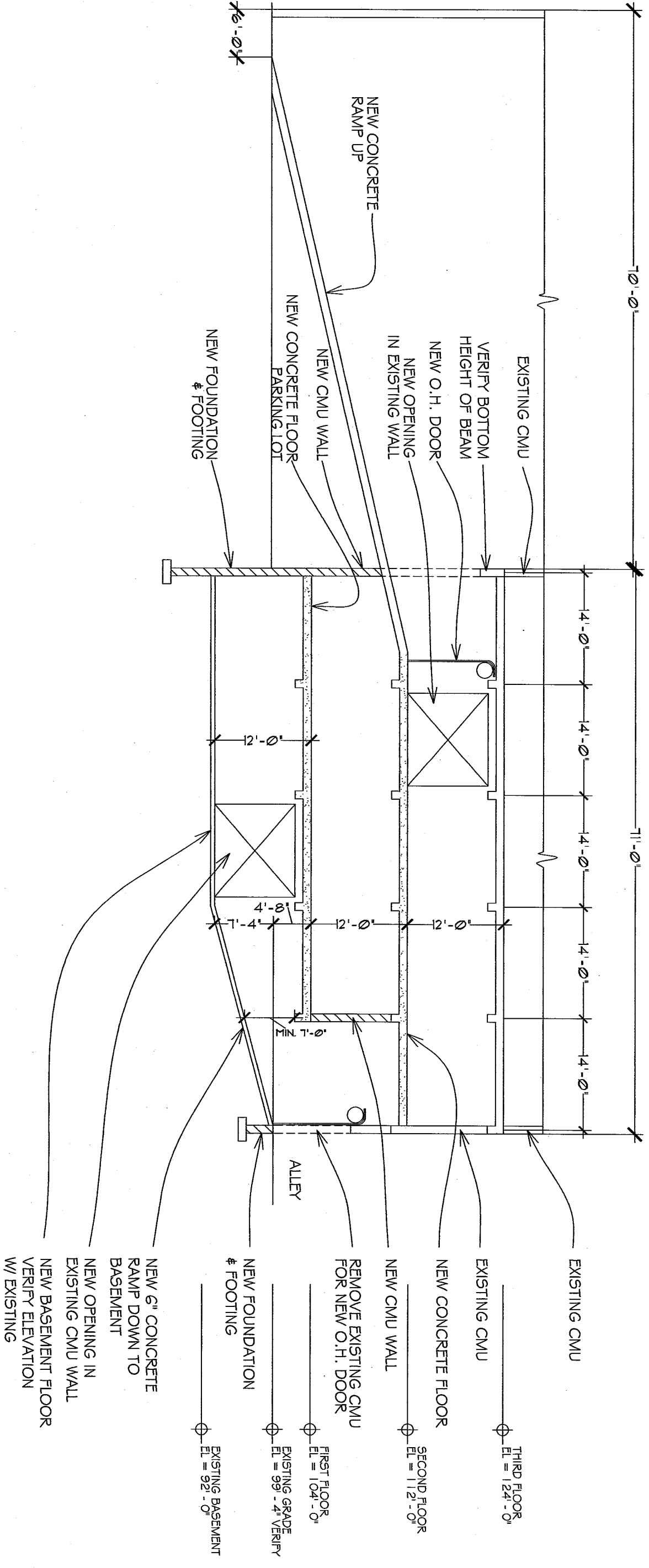

SECTION THRU RAMPS

DATE ISSUED : 07/25/02

Logo 3rd Coast, llc

Architects and Planners

Project Title

TEWELES SEED
COMPANY LOFT APARTMENTS
222 S. THIRD STREET, MILWAUKEE, WISCONSIN

Sheet Title
SECTION THRU
RAMPS @
OREGON ST.

Signature Block _____ Date _____
Owner _____
Architect _____
Builder _____
Surety _____

Proj. no. 0108
Date 07/25/02
Check by RJS
Drawn by BRS
Revisions

SHEET 4 OF 4

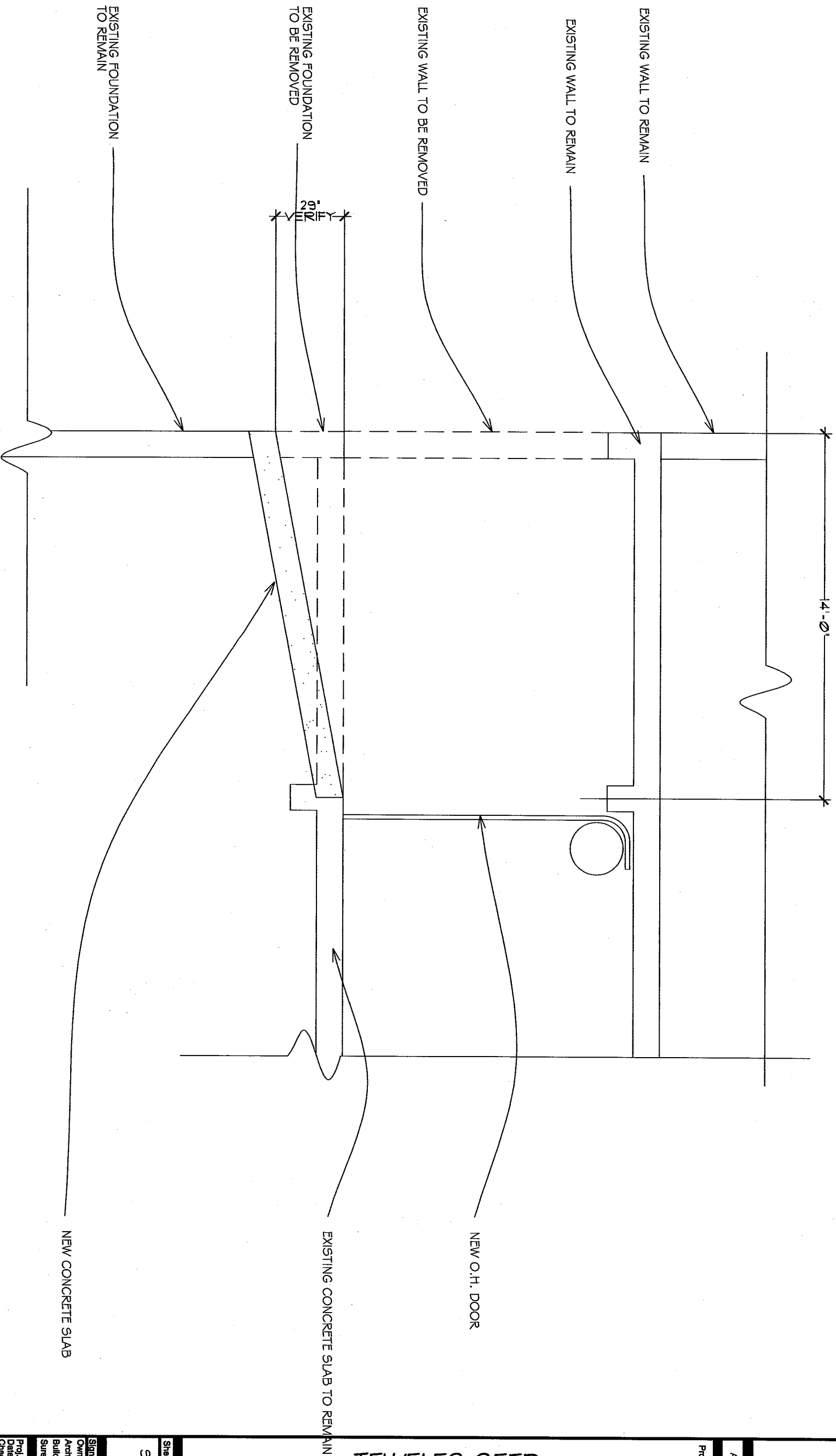

SECTION THRU RAMP @ OREGON ST

DATE ISSUED : 07/25/02

1/4" = 1'-0"

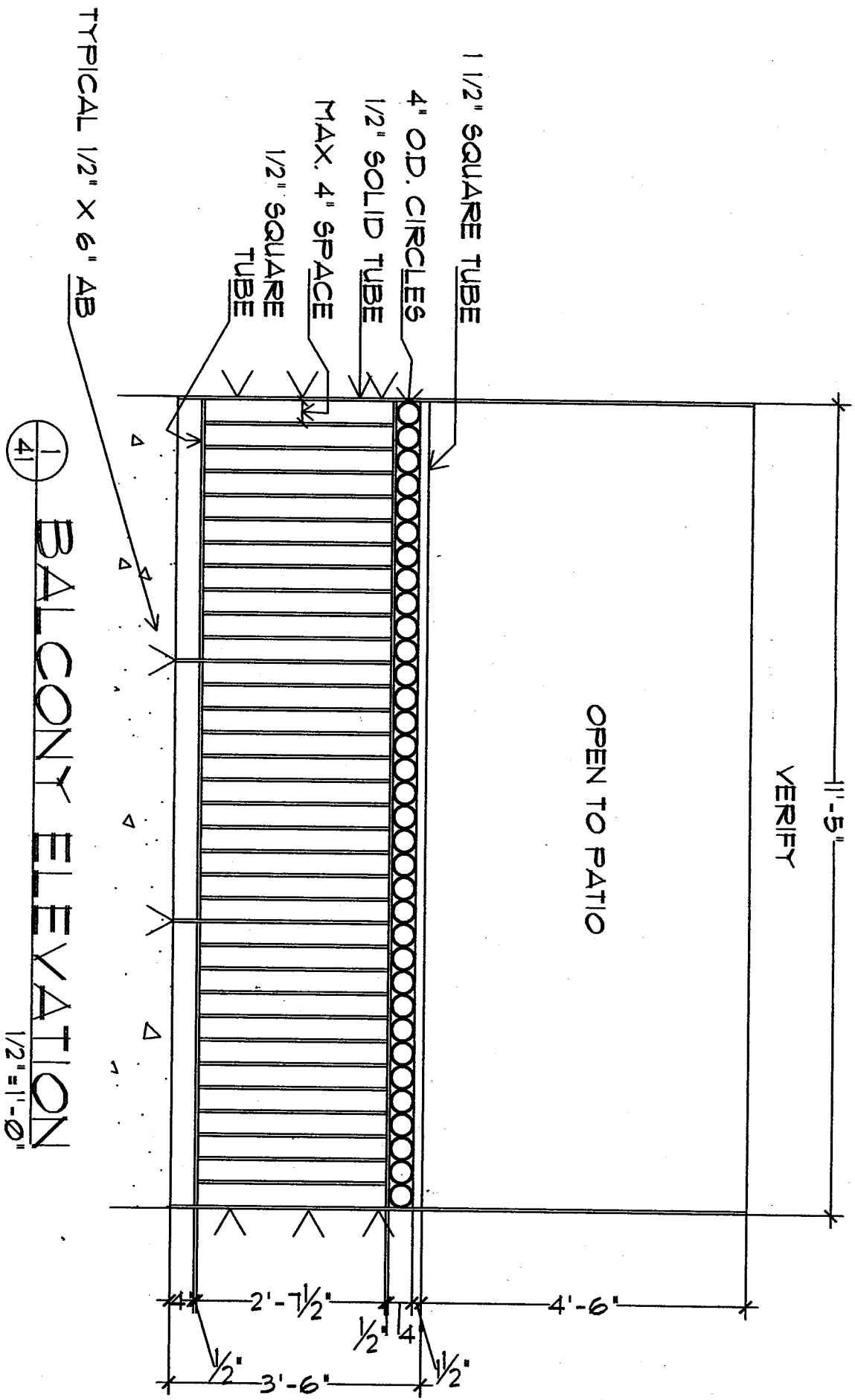

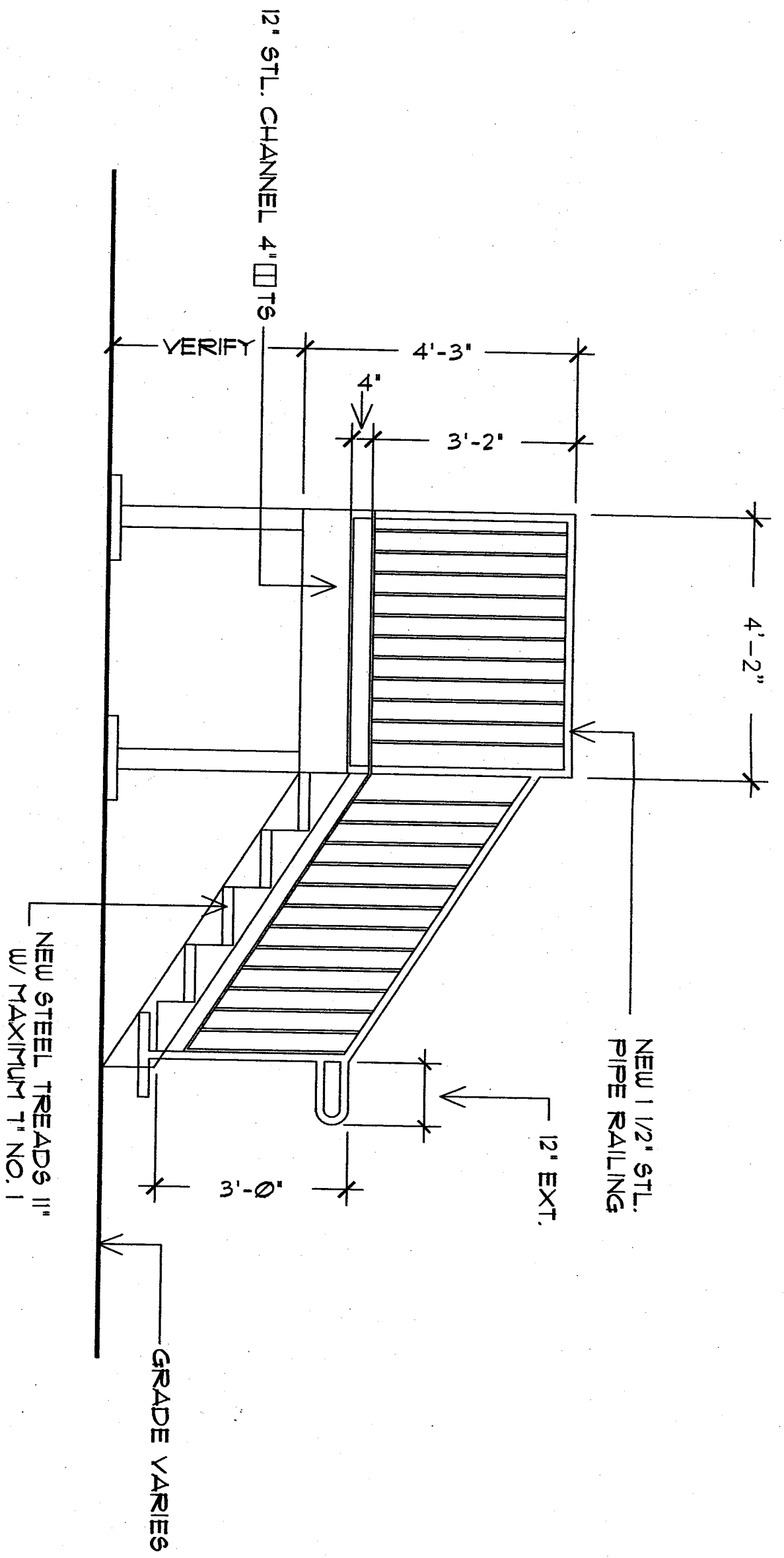

○ NEW STEEL STAIRS @ STAIRS NO. 1

BUILDING NARRATIVE

There are 115 total units in the building. Four one-bedroom units were added in the 9th, 10th, 11th, and 12th floors. Final rent levels have not been finalized.

The project is the retrofitting of an existing warehouse, which is approximately 190,646 SF as it exists right now. The project includes approximately 16,180 SF of new additional floor space. There will be a total of 206,826 SF in the project. The new additional floor space will consist of new floors connecting the two towers at the basement, first floor and second floors. The third through seventh floors will remain the same size. New floor area will be added to the east side of the building at the eighth through twelfth floors by extending these floors out one or two bays to the east. This maximizes the views from the building. The thirteenth floor will be enlarged substantially and a new 14th floor will be added. The new floor will be an all new poured floor built within the existing height confines of the existing penthouse. These two levels (13th and 14th floors) are the penthouse levels and are intended to maximize the rents for the best units.

The units are oversized, ranging from 624 SF (for a studio, normally enough SF for a one bedroom) upwards to 1,535 SF for a 3 bedroom unit with a media room/den. More than one half of the units have a den or media room for computer space. All the units will include a utility room/closet to provide internal storage. The units include stainless steel appliances, granite countertops and where we are able to, a master comfort area with a 3x5 shower.

The unit sizes and numbers for the 'affordable' units are as follows:

<u>Qt.</u>	<u>Type</u>	<u>Bath</u>	<u>SF</u>
6	studios	1	624
3	1bedroom/den	1	894
3	1bedroom/den	1	795
8	1bedroom	1	966
4	1bedroom	1	685
1	1bedroom	1	752
1	1bedroom/den	1	894
1	1bedroom/den	1	795
2	1bedroom	1	966
5	2bedroom	2	1167
5	2bedroom	1	1074
3	2bedroom	2	1188
5	2bedroom	2	1059
4	2bedroom	2	830
1	2bedroom	2	953
1	2bedroom	2	952
1	2bedroom/den	2	1363
1	2bedroom/den	2	1397
4	2bedroom	2	1321
4	2bedroom/den	2	1351
1	3bedroom/den	2	1535
4	3bedroom/den	2	1455

The unit sizes and numbers for 'market' rate units are as follows:

5	1bedroom/den	1	681
10	1bedroom/den	1	805
2	2bedroom	2	1188
6	2bedroom/den	2	1470
1	2bedroom	2	1321
1	2bedroom/den	2	1434
1	3bedroom/den	2	1455
5	3bedroom/den	2	1264
10	2bedroom/den	2	1369
4	2bedroom/den	2	1115
2	3bedroom/den	2	1272

Note: These square footages are subject to minor change.

The amenities of the market rate and affordable units are the same. The big difference is the market rate units have the best views. These market rate units are generally located from the seventh floor and up.

There are 98 internal parking spaces and 18 external parking spaces. There will be an option for car lifts, for each unit, which allow for an electric module to hold one car above another. These lifts may possibly double the number of internal parking spaces.

Common spaces consist of an office area to house CommonBond's 'Advantage Centers'. These 'Advantage Centers' have a nationally recognized educational program to assist low income residents. Typical programs include English and computer courses.

Additional common spaces include conference rooms, community center, theater and rooftop patio area. Alternates are being sought for a rooftop putting green, video golf and basketball court.

PROPOSED TEWELES GROUND MT. SIGN

SIGNAGE

These instructions and

cement of elements.

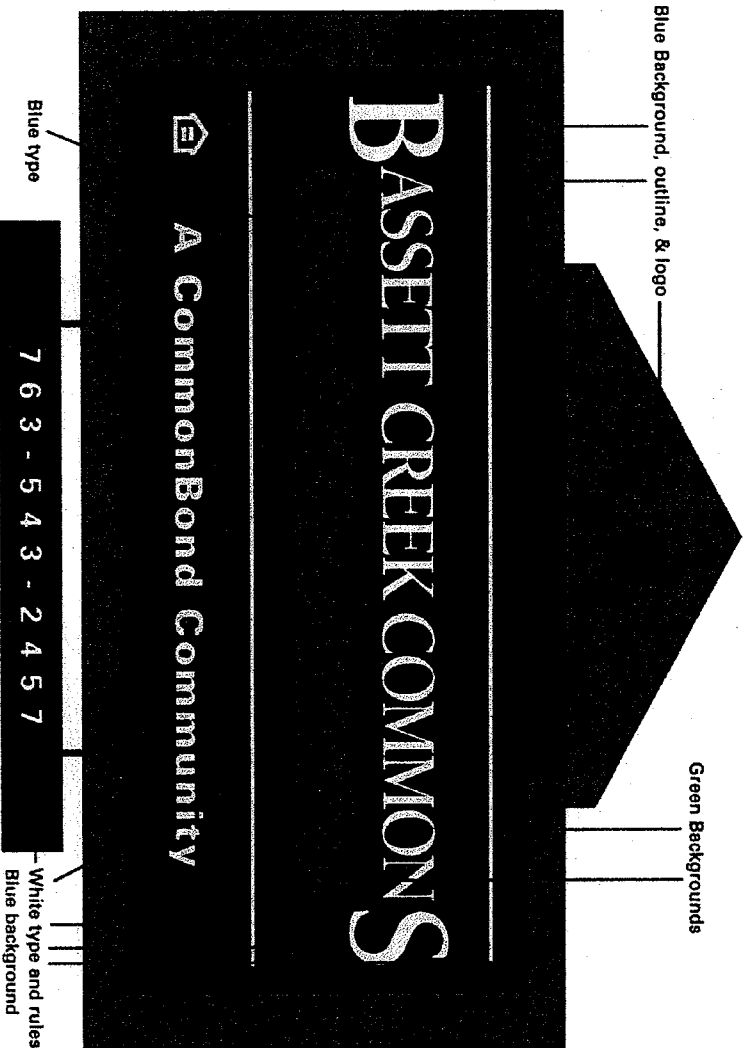

Sign Specifications
based on 7" x 4-1/2" sign,
not including phone hanger

Address is 14 pt Unifers Bold Caps,
90 letter spacing

Colors:
Blue: (PMS Match 286U)
Benjamin Moore
2066-20

Fonts
Site name is 40 pt Berkeley Bold,
85% horizontal scale,
-14 letter space

A CommonBond Community is
19 pt Unifers Black, 10 letter spac-
ing

Evening Blue

Site name first and last initials
are 74 pt Berkeley Bold

Phone number is
15 pt Unifers Bold Caps,
100 letter spacing

Green: (PMS Match 577U)
Pratt Lambert
1656
Reed Roseau

The above standard sign shall be
modified as follows:

HISTORIC
TEWELES SEED CO. LOFTS
222 SOUTH THIRD STREET

EO Logo
RIS Div.
CA Logo

A Common Bond Community &
Robert J. Schultz Development Co. Project

Verify telephone number on hanging sign.