



CERTIFICATE OF APPROPRIATENESS APPLICATION FORM

Incomplete applications will not be processed for Commission review.
Please print legibly.

1. HISTORIC NAME OF PROPERTY OR HISTORIC DISTRICT: (if known) *NORTH POINT*

ADDRESS OF PROPERTY: *2604 N. LAKE DRIVE. MILWAUKEE*

2. NAME AND ADDRESS OF OWNER:

Name(s): *DIANE DZIENDEL / MICHAEL HOSALE / CINDY HOSALE*

Address:

2604 N. LAKE DRIVE
City: *MILWAUKEE*

State: *WIS*

ZIP: *53211*

Email: *CYNHOSALE@gmail.com*

Telephone number (area code & number) Daytime: *414 491 3792* Evening: *414 491 3792*
CINDY CELL *CINDY CELL*

*Revised
10/8/2015*

3. APPLICANT, AGENT OR CONTRACTOR: (if different from owner)

Name(s): *WINTERS REMODELING GROUP LLC*

Address: *7772 HARWOOD AVENUE*

City: *WAUWATOSA*

State: *WI*

ZIP Code: *53213*

Email: *WINTERSGROUPLLC@hpeprint.com*

Telephone number (area code & number) Daytime: *414-771-6202* Evening: *414 218 9215*

4. ATTACHMENTS: (Because projects can vary in size and scope, please call the HPC Office at 414-286-5712 for submittal requirements)

A. REQUIRED FOR MAJOR PROJECTS:

N/A Photographs of affected areas & all sides of the building (annotated photos recommended)

N/A Sketches and Elevation Drawings (1 full size and 1 reduced to 11" x 17" or 8 1/2" x 11")
A digital copy of the photos and drawings is also requested.

Material and Design Specifications (see next page)

B. NEW CONSTRUCTION ALSO REQUIRES:

Floor Plans (1 full size and 1 reduced to a maximum of 11" x 17")

Site Plan showing location of project and adjoining structures and fences

PLEASE NOTE: **YOUR APPLICATION CANNOT BE PROCESSED UNLESS BOTH PAGES OF THIS FORM ARE PROPERLY COMPLETED AND SIGNED.**

5. DESCRIPTION OF PROJECT: SEE ATTACHED DRAWINGS

Tell us what you want to do. Describe all proposed work including materials, design, and dimensions. Additional pages may be attached.

WE WANT TO ADD APPROXIMATELY (11) CUSTOM MADE "SCUPPER" BOXES AT EACH 4" DOWNSPOUT. (SEE ATTACHED INFO SHEET) THESE SCUPPER BOXES WOULD BE MOUNTED ON THE BRICK PORTION OF THE HOUSE (SEE ATTACHED PHOTO) THESE "BOXES" WOULD BE MADE OUT OF COPPER TO MATCH THE COPPER BUTTERS AND DOWNSPOUTS.

THE DESIGN IS HISTORICALLY ACCURATE IN RELATIONSHIP TO THE ERA OF THE HOUSE, BUT SERVES A USEFUL PURPOSE IN COLLECTING LEAVES/SEEDS/ ETC BEFORE THEY ENTER THE STORM WATER SYSTEM.

THESE BOXES WILL ENHANCE THE HISTORICAL ASPECTS OF THIS PROJECT IN A VERY POSITIVE WAY.

6. SIGNATURE OF APPLICANT.

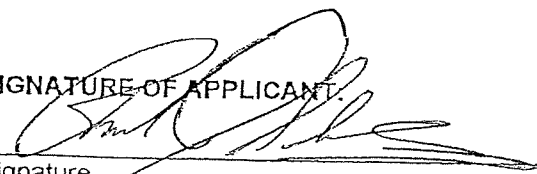

Signature

ROBERT J SCHULZ - FOR WINTERS

Please print or type name

Date

10-5-15

This form and all supporting documentation **MUST** arrive by 12:00 noon on the deadline date established to be considered at the next Historic Preservation Commission Meeting. Any information not provided to staff in advance of the meeting will not be considered by the Commission during their deliberation. Please call if you have any questions and staff will assist you.

Hand Deliver or Mail Form to:
Historic Preservation Commission
City Clerk's Office
200 E. Wells St. Room B-4
Milwaukee, WI 53202

PHONE: (414) 286-5722

FAX: (414) 286-3004

www.milwaukee.gov/hpc

2604 N LAKE DRIVE

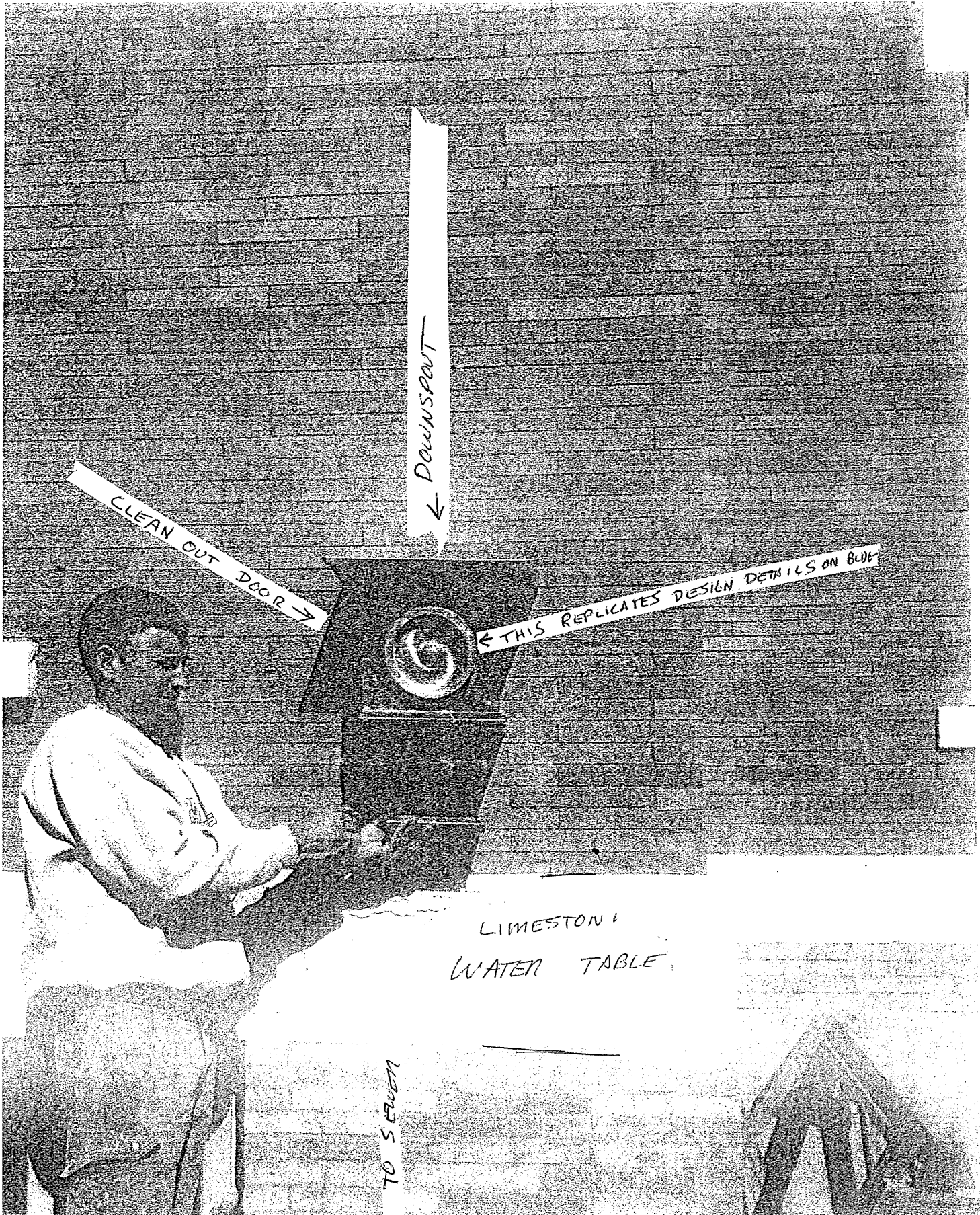

CLEAN OUT DOOR →

← DOWNSPOUT

← THIS REPLICATES DESIGN DETAILS ON BUDG

LIMESTONE
WATER TABLE

TO S EARTH

Winters Remodeling Group
Design - Build
7772 Harwood Avenue
Wauwatosa, Wisconsin 53213

2604 N. LAKE DRIVE

OWNERS

DIANNE DZIENGE

MICHAEL NOSALE

CINDY NOSALE

MOUNTED ON HOUSE
AT EVERY DOWNSPOUT
AT BRICK WALL
IMMEDIATELY ABOVE
LIMESTONE WATER TABLE

FROM
GUTTERS
4" ROUND
COPPER
DOWNSPOUT
FEEDS INTO
COLLECTOR BOX

PROTOTYPE - LEAF

COLLECTOR - ALL COPPER -
ABOUT 10" WIDE 18"
8" DEEP HIGH
WITH COPPER DOOR

OPEN THE DOOR AND THERE
IS A TRAY WITH A SCREENED
BOTTOM TO COLLECT LEAVES
AND OTHER DEBRIS TO STOP
THEM FROM GETTING INTO THE
SEWER LINE

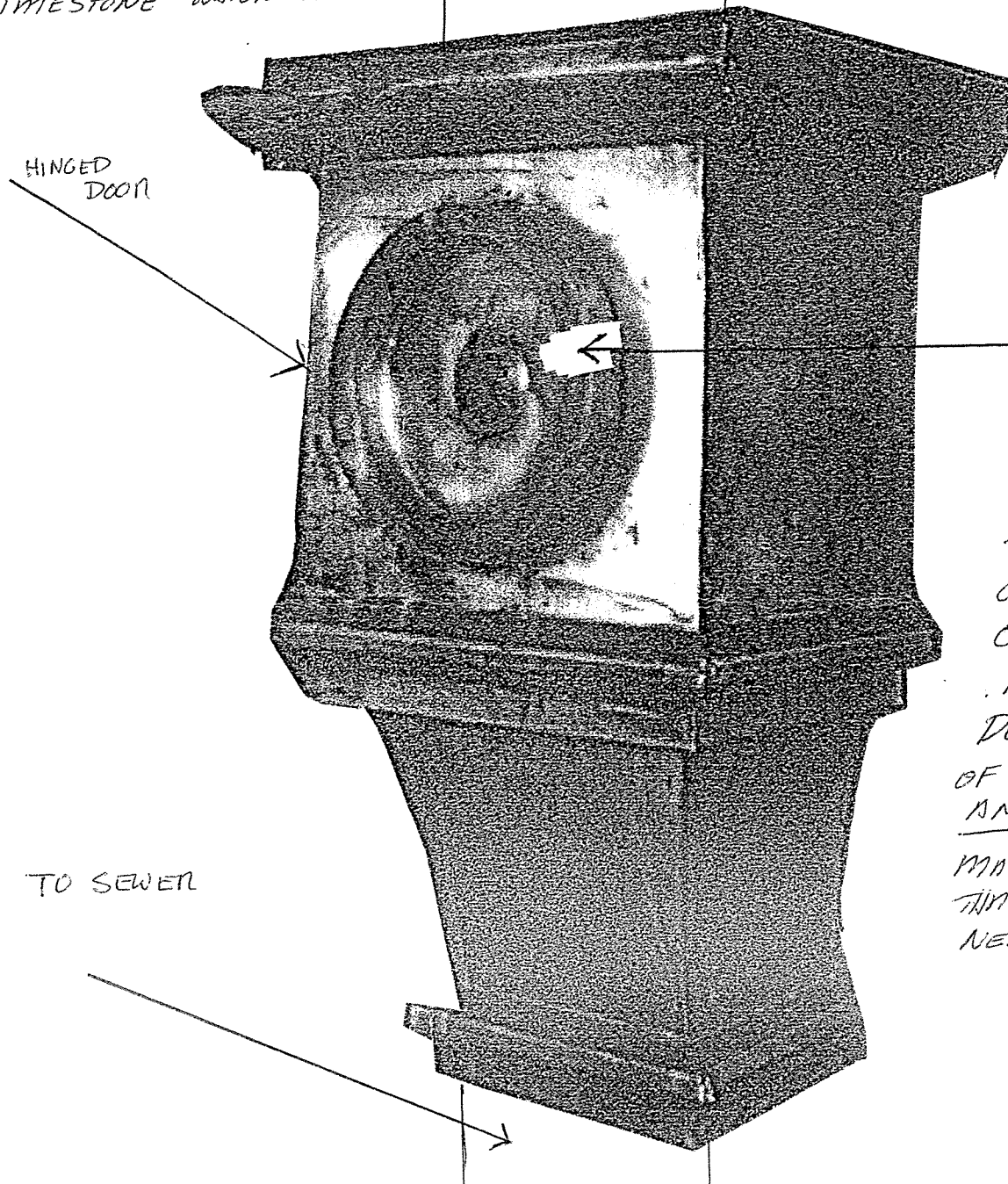

THIS ROSSETTE DETAIL
IS CARRIED ON
ELSEWHERE ON
THE PROJECT

THE DESIGN
OF THIS "BOX"
COMPLIMENTS THE
HISTORICAL
DESIGN ELEMENTS
OF THE EXISTING HOUSE
AND REPLICATES
MANY SCUPPER BOXES
THROUGHOUT THIS
NEIGHBORHOOD



PROTOTYPE

FABRICATED TO SHOW
DETAILS



2604 N LAKE
DRIVE

