



SUBMITTAL DATA

For: Approval

Order #:

Date: 03/19/2018

Project: CMS- DOGE 19014

Project #:

Location:

Date

03/19/2018

Project Name

CMS- DOGE 19014

Project Number

Client / Purchaser



Submittal Summary Page

Qty	Tag #	Model #	Description
1		ZF240N30P2A1AAA1A1	<p>20 Ton, Two Stage Cooling, York Large Sunline Single Packaged R-410A Air Conditioner, 9.8 EER, 300 MBH Input Aluminized Steel, Two Stage Gas Heat, 208/230-3-60, Single Wall Construction</p> <ul style="list-style-type: none"> • IntelliSpeed control of the VFD based on stages of cooling. <p>Provides Single Zone VAV Fan Operation as defined by ASHRAE 90.1 section 6.4.3.10.</p> <ul style="list-style-type: none"> • Includes fresh air hood with baffle that can be set for 10, 15, or 25% outside air. • 5 HP Standard Static Belt Drive Blower • 2" Throwaway Filters • Simplicity® SE Controller including Discharge Air, Return Air, and Outdoor Air Temperature Sensors. • Standard Condenser Coil • Standard Evaporator Coil • Standard Access Doors • Galvanized Steel Drain Pan
1		1HG0407	Hail Guard Kit

Equipment start-up and commissioning by a factory trained technician is recommended.
 Contact your supplying distributor or sales representative for additional information & guidance.



Large Sunline (15-25 Ton Package) N540

Single Package R-410A Air Conditioner

Project Name: CMS- DOGE 19014

Unit Model #: ZF240N30P2A1AAA1A1

Quantity: 1

System: ZF240N30P2A1AAA1A1

Cooling Performance

Total gross capacity	260.4 MBH
Sensible gross capacity	189.3 MBH
Efficiency (at ARI)	9.80 EER
Integrated eff. (at ARI)	12.30 IEER
Ambient DB temp.	95.0 °F
Entering DB temp.	80.0 °F
Entering WB temp.	67.0 °F
Leaving DB temp.	58.1 °F
Leaving WB temp.	56.7 °F
Power input (w/o blower)	22.57 kW
Sound power	92 dB(A)

Refrigerant

Refrigerant type	R-410A
Sys1	22 lbs
Sys2	23 lbs 8 oz

Gas Heating Performance

Entering DB temp.	60 °F
Heating output capacity (Max)	240 MBH
Supply air	8000 CFM
Heating input capacity (Max)	300 MBH
Leaving DB temp.	87.8 °F
Air temp. rise	27.8 °F
SSE	80.0 %
Stages	2

Supply Air Blower Performance

Supply air	8000 CFM
Ext. static pressure	0.4 IWG
Blower speed	890 RPM
Max BHP of Motor (including service factor)	5.75 HP
Duct location	Bottom
Motor rating	5.00 HP
Actual required BHP	5.30 HP
Power input	4.44 kW
Elevation	0 ft.
Drive type	BELT

Electrical Data

Power supply	230-3-60
Unit min circuit ampacity	101.4 Amps
Unit max over-current protection	125 Amps

Dimensions & Weight

Hgt	53 in.	Len	137 in.	Wth	92 in.
Weight with factory installed options					2763 lbs.

Clearances

Right	36 in.	Front	36 in.	Back	24 in.
Top	72 in.	Bottom	0 in.	Left	24 in.

Note: Please refer to the tech guide for listed maximum static pressures



20 Ton

- York Sunline Units are Manufactured at an ISO 9001 Registered Facility and Each Rooftop is Completely Computer-Run Tested Prior to Shipment.

Unit Features

- Two Stage Cooling
- 300 MBH Input Aluminized Steel, Two Stage Gas Heat
- Full Perimeter Base Rails with Built in Rigging Capabilities
- Either Supply and/or Return can be Field Converted from Vertical to Horizontal Configuration without Cutting Panels
- Unit Cabinet Constructed of Powder Painted Steel, Certified At 1000 Hours Salt Spray Test (ASTM B-117 Standards).
- Dual Refrigerant Circuits for Efficient Part Load Operation with Scroll Compressors
- 5 HP Standard Static Belt Drive Blower
- Unit Ships with 2" Throwaway Filters
- Solid Core Liquid Line Filter Driers
- Replacement Filters: 4 - (16" x 25" x 2" or 4") AND 4 - (16" x 20" x 2" or 4"). Unit accepts 2" or 4" wide filters.
- Short Circuit Current: 5kA RMS Symmetrical
- Through-the-Curb and Through-The-Base Utility Connections
- Single Point Power Connection
- Standard Condenser Coil
- Standard Evaporator Coil
- Crane Required to Unload Unit
- Galvanized Steel Drain Pan
- Standard Access Doors

BAS Controller

- IntelliSpeed control of the VFD based on stages of cooling. Provides Single Zone VAV Fan Operation as defined by ASHRAE 90.1 section 6.4.3.10.
- Simplicity SE Controller including Discharge Air, Return Air, and Outdoor Air Temperature Sensors

Standard Unit Controller: Simplicity Control Board

- An Integrated Low-Ambient Control, Anti-Short Cycle Protection, Lead-Lag, Fan On and Fan off Delays, Low Voltage Protection, On-Board Diagnostic and Fault Code Display. Allows all units to operate in the cooling mode down to 0 °F outdoor ambient without additional components or intervention.
- Safety Monitoring - Monitors the High and Low-Pressure Switches, the Freezestats, the Gas Valve, if Applicable, and the Temperature Limit Switch on Gas and Electric Heat Units. The Unit Control Board will Alarm on Ignition Failures, Safety Lockouts and Repeated Limit Switch Trips.

Warranty

- One (1) Year Limited Warranty on the Complete Unit
- Five (5) Year Warranty - Compressors and Electric Heater Elements
- Ten (10) Year Warranty - Aluminized Steel Tubular Heat Exchangers



Large Sunline (15-25 Ton Package) N540

Single Package R-410A Air Conditioner

Project Name: CMS- DOGE 19014

Unit Model #: ZF240N30P2A1AAA1A1

Quantity: 1

System: ZF240N30P2A1AAA1A1

Factory Installed Options

ZF240N30P2A1AAA1A1

Product Category:	ZF	York Large Sunline Single Packaged R-410A Air Conditioner 9.8 EER
Nominal Cooling Capacity:	240	20 Ton Two Stage Cooling
Heat Type and Nominal Heat Capacity:	N30	300 MBH Input Aluminized Steel, Two Stage Gas Heat
Blower Option:	P	IntelliSpeed control of the VFD based on stages of cooling. Provides Single Zone VAV Fan Operation as defined by ASHRAE 90.1 section 6.4.3.10. 5 HP Standard Static Belt Drive Blower
Voltage:	2	208/230-3-60
Economizer / Damper:	A	Includes fresh air hood with baffle that can be set for 10, 15, or 25% outside air.
Service Options:	1	
Sensor Options:	A	
Controls:	A	Simplicity® SE Controller including Discharge Air, Return Air, and Outdoor Air Temperature Sensors.
Refrigeration:	A	Standard Condenser Coil Standard Evaporator Coil
Additional Options:	1	2" Throwaway Filters
Cabinet Options:	A	Single Wall Construction Standard Access Doors Galvanized Steel Drain Pan
Product Generation:	1	

Field Installed Accessories

- 1HG0407 - Hail Guard Kit (57.0 lbs)

Single Package R-410A Air Conditioner

Project Name: CMS- DOGE 19014

Unit Model #: ZF240N30P2A1AAA1A1

Quantity: 1

System: ZF240N30P2A1AAA1A1

Consolidated Drawing

NOTES:

1. FOR OUTDOOR USE ONLY.
2. WEIGHTS SHOWN ARE FOR COOLING ONLY UNITS.
3. MIN. CLEARANCES TO BE:
 - RIGHT SIDE: 36 [914,4]
 - LEFT SIDE: 24 [609,6] (LESS ECONOMIZER)
 - FRONT: 36 [914,4] (WITH ECONOMIZER)
 - REAR: 24 [609,6] (LESS ECONOMIZER)
 - TOP: 49 [1244,6] (WITH ECONOMIZER)
 - 72 [1828,8] WITH 36 [914,4] MAX. HORIZ. OVERHANG (FOR CONDENSER AIR DISCHARGE)
 - BOTTOM: 0 [0]
4. FOR SMALLER SERVICE AND OPERATIONAL CLEARANCES CONTACT YOUR APPLICATION ENGINEERING DEPARTMENT.
5. DOWNFLOW DUCTS DESIGNED TO BE ATTACHED TO ACCESSORY ROOF CURB ONLY. IF UNIT IS MOUNTED SIDE SUPPLY, IT IS RECOMMENDED THAT THE DUCTS ARE SUPPORTED BY CROSS BRACES, AS DONE ON ACCESSORY ROOF CURBS.
6. SIDE DUCT FLANGES ARE 0.875" [22,2] HIGH. BOTTOM DUCTS DO NOT HAVE FLANGES.
7. MINIMUM CONDENSATION TRAP HEIGHT SHALL BE 1.5 TIMES THE LOWEST NEGATIVE STATIC.
8. DIMENSIONS IN [] ARE IN MILLIMETERS OR KILOGRAMS.
9. OPTIONAL COIL GUARD, GAS HEAT, ECONOMIZER HOOD, DISCONNECT SWITCH, CONVENIENCE OUTLET, AND OUTLET/INLET HOOD SHOWN.

EXCEPT XP (HEAT PUMP) UNITS.

DIRECTION OF AIRFLOW

CENTER OF GRAVITY

TONNAGE	UNIT	OPERATING WEIGHT (LBS) (BASE UNIT)	CENTER OF GRAVITY LOCATION (BASE UNIT)		4 POINT CORNER LOADS (LBS) (BASE UNIT)			
			X	Y	A	B	C	D
17.5	ZF	2006 [910]	70.98 [1802,9]	45 [1143]	470 [213]	511 [232]	534 [242]	491 [223]
20	ZF	2533 [1149]	70 [1778]	44 [1117,6]	589 [267]	622 [282]	679 [308]	643 [292]
25	ZF	2597 [1178]	70 [1778]	44.5 [1130,3]	611 [277]	645 [293]	689 [313]	652 [296]
15	XP	2140 [971]	77.1 [1958,3]	45 [1143]	454 [206]	592 [269]	619 [281]	475 [216]

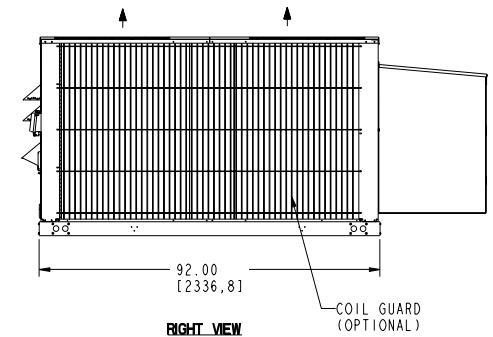
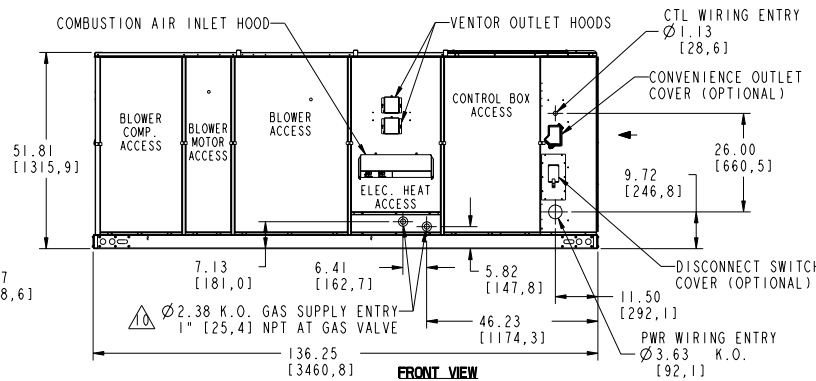
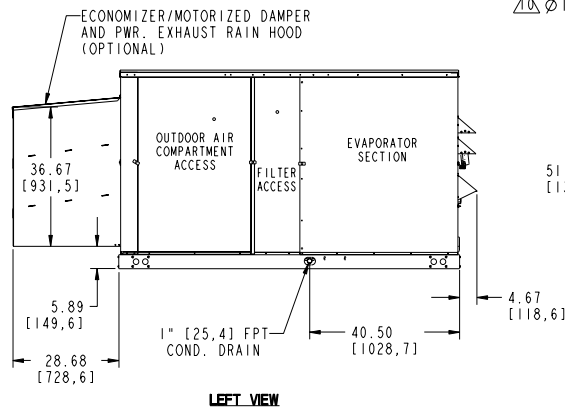
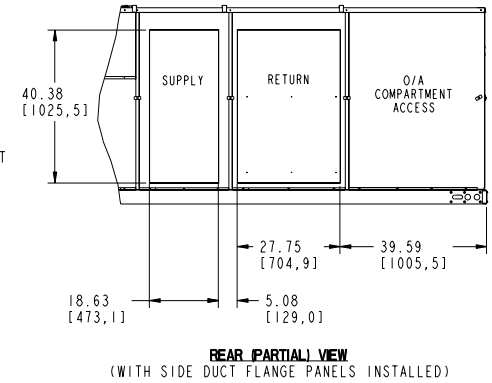
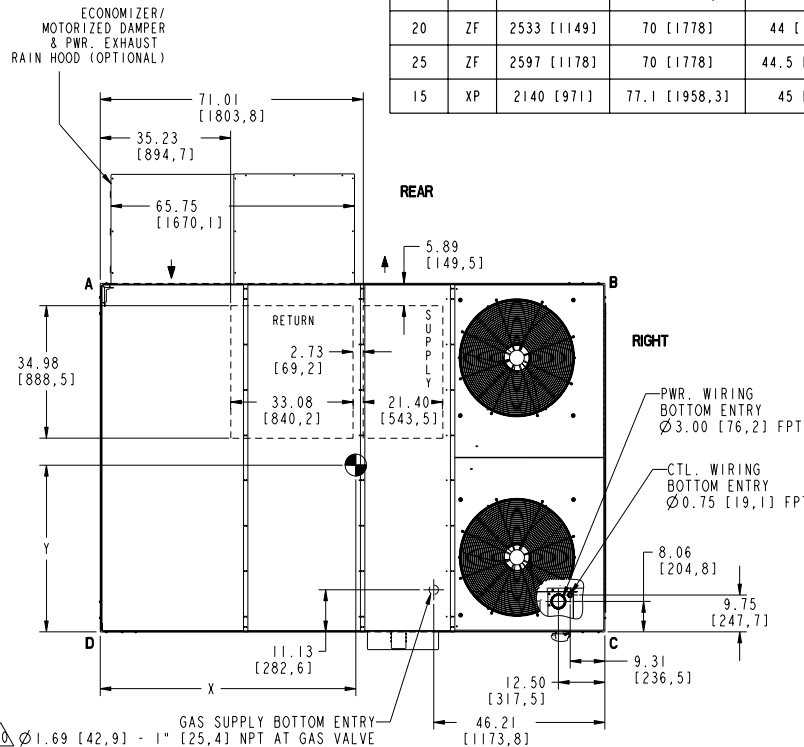

Single Package R-410A Air Conditioner

Project Name: CMS- DOGE 19014

Unit Model #: ZF240N30P2A1AAA1A1

Quantity: 1

System: ZF240N30P2A1AAA1A1

Component Locations

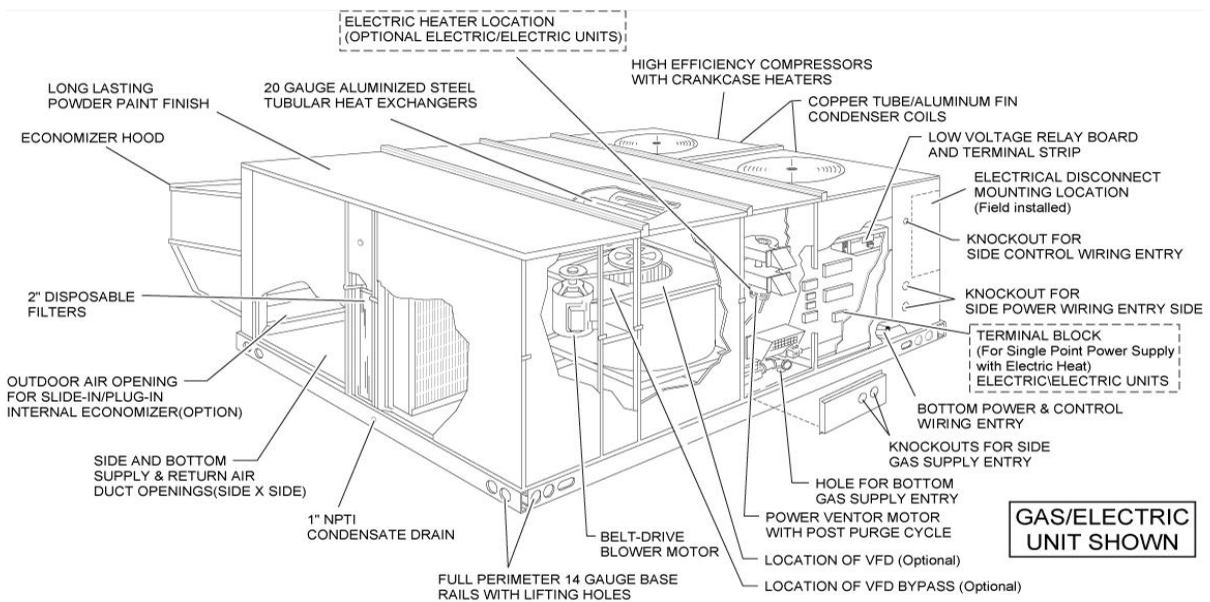

Project Name: CMS- DOGE 19014

Unit Model #: ZF240N30P2A1AAA1A1

Quantity: 1

System: ZF240N30P2A1AAA1A1

Typical Application

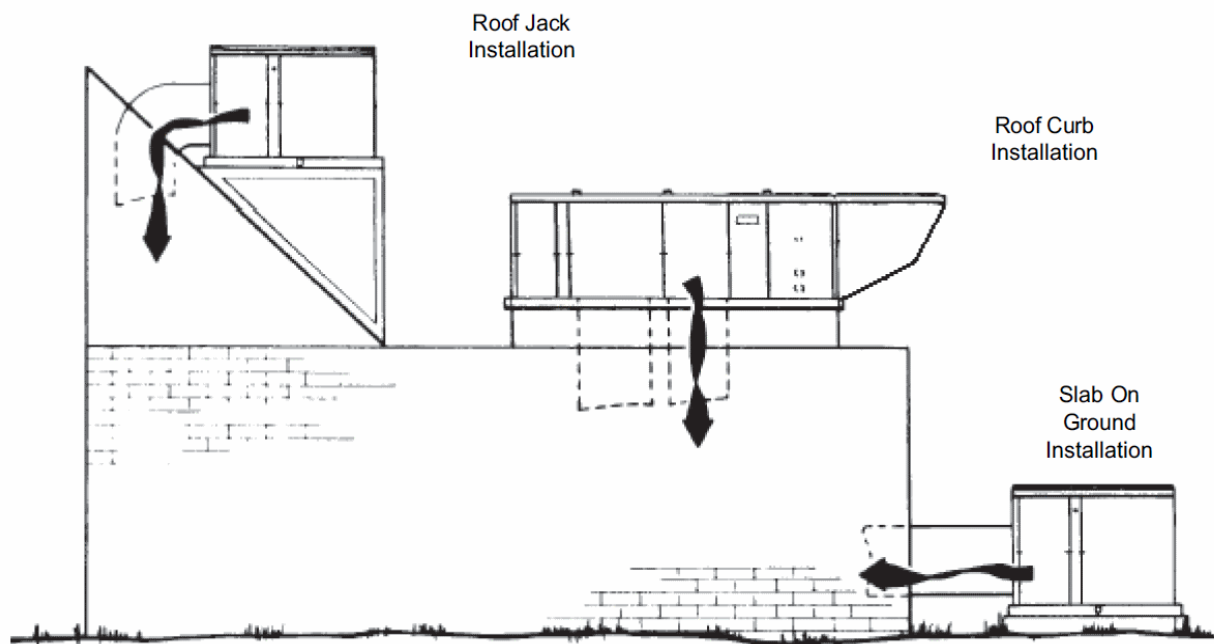

Project Name: CMS- DOGE 19014

Unit Model #: ZF240N30P2A1AAA1A1

Quantity: 1

System: ZF240N30P2A1AAA1A1

Typical Control Diagram

Typical Control Diagram

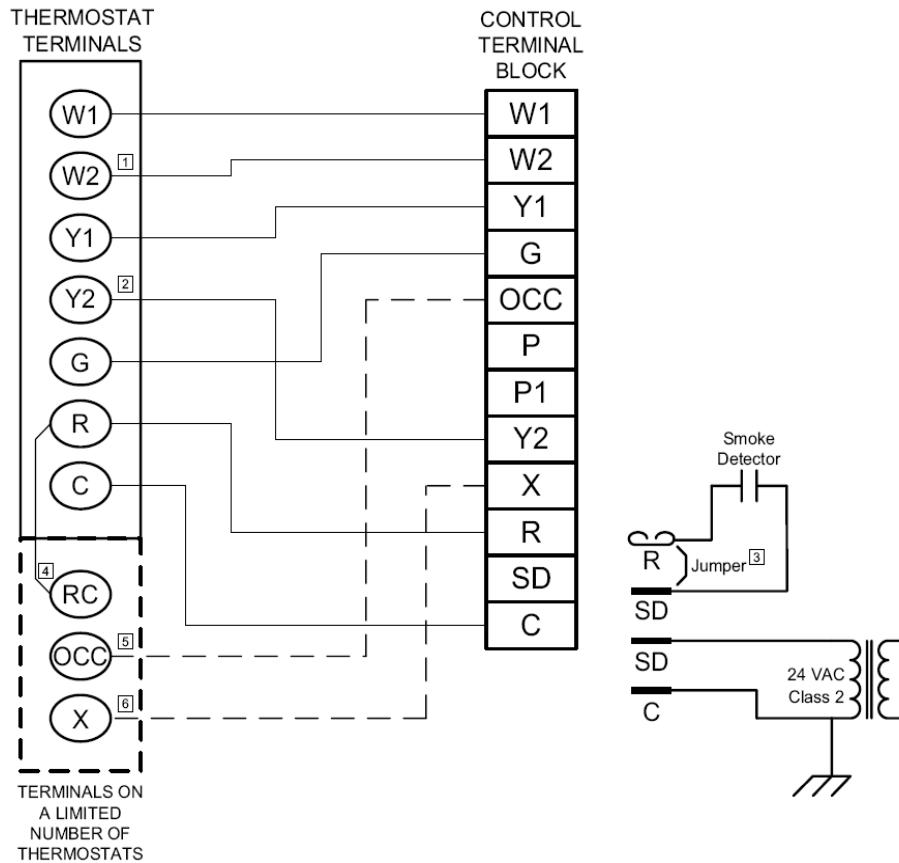

- 1 Second stage heating not required on single stage heating units.
- 2 Second stage cooling not required on single stage cooling units.
- 3 Jumper is required if there is no Smoke Detector circuit.
- 4 Jumper is required for any combination of R, RC, or RH.
- 5 OCC is an output from the thermostat to indicate the Occupied condition.
- 6 X is an input to the thermostat to display Error Status conditions.



Large Sunline (15-25 Ton Package) N540

Single Package R-410A Air Conditioner

Project Name: CMS- DOGE 19014

Unit Model #: ZF240N30P2A1AAA1A1

Quantity: 1

System: ZF240N30P2A1AAA1A1

Seismic Certification

835356-UAD-A-0112



SPECIAL SEISMIC CERTIFICATION
OF NON STRUCTURAL
COMPONENTS AND SYSTEMS



CERTIFICATE OF COMPLIANCE

Dynamic Certification Laboratories has qualified the listed packaged rooftop units as CERTIFIED for seismic applications in accordance with the following codes and standards:

CBC 2010, IBC 2009, ICC ES AC 156 2010, ASCE 7 05

The following model designations are included in this certification. A complete list of certified models, options, and installation methods are detailed in report number 90300 1108b by Dynamic Certification Laboratories, provided by the equipment manufacturer upon request.

Unitary Product Group Packaged Rooftop Units (UPG)

Seismic Qualification Testing was conducted in accordance with and in strict adherence to the standards set forth within the American Society of Civil Engineers (ASCE 7) by the independent approval agency, Dynamic Certification Laboratories. The above referenced equipment is APPROVED for seismic applications when properly installed and used as intended.

The basis of this certification is through testing of the active and energized components per AC156. This certification covers multiple UPG brands, including York, Johnson Controls, Coleman, Luxaire, Evcon and Fraser Johnston.

The seismic values are obtained from the Maximum Considered Earthquake Short Period Spectral Response Acceleration, Sds, as determined by the ASCE 7 seismic maps. Various installation locations/isolation configurations are covered under this certification, limited by the Sds value stated in the following table. A seismic importance factor, Ip, of 1.5 applies to this certification to include essential facility requirements and life safety applications for post event functionality. The units are approved for both a rigid and flexible mount configuration.

Maximum Design Sds Values of UPG Packaged Rooftop Units				
Series	Size	Tons	Sds (g)	Fp/Wp
ZF/ZS 180/J**ZF/T*	180 (48")	15	2.0	1.5
ZF/ZS/J**ZF/T*	210, 240, 300 (53")	17.5, 20, 25	2.0	1.5
XP/XA/J**XP/T* 180	180 (53")	15	2.0	1.5
XP/XA/J**XP/T* 240	240 (53")	20	2.0	1.5
ZJ/ZW/J**ZJ/T*	180, 210, 240, 300 (53")	15, 17.5, 20, 25	2.0	1.5
ZR/ZK 180/J**ZR/T*	240, 300 (53")	15, 20, 25	2.0	1.5

Page 1 of 2

Dynamic Certification Laboratories 1315 Greg Street, Suite 109, Sparks, NV 89431 – ph: 775 358 5085

www.shaketest.com

Johnson Controls Unitary Products

1

Project Name: CMS- DOGE 19014

Unit Model #: ZF240N30P2A1AAA1A1

Quantity: 1

System: ZF240N30P2A1AAA1A1

Seismic Certification



SPECIAL SEISMIC CERTIFICATION OF NON-STRUCTURAL COMPONENTS AND SYSTEMS



CERTIFICATE OF COMPLIANCE

Table of Seismic Design Parameters					
Site Class	F _a	I _p	a _p	R _p	z/h
D	1.0	1.5	2.5	6.0	1.0

Site and Project Requirements

It is the responsibility of the Design Professional of Record to:

- Provide engineering for the anchorage and restraint of the unit
- Validate Certification Design Parameters with actual site conditions
- Provide engineering of all equipment support structures
- Confirm component configuration

Certification Issued by: Dynamic Certification Laboratories

Document Control Number: 90300-1108b-1

Issue Date: 12/19/11



Dr. Ahmad Itani, SE
Dynamic Certification Laboratories



Randy Forristall
YORK Unitary Engineering
Johnson Controls, Incorporated

Page 2 of 2

Date

03/19/2018

Project Name

CMS- DOGE 19014

Project Number

Client / Purchaser



Guide Specification Summary Page

Product Series	Models and Unit Tags
Large Sunline (15-25 Ton Package) N540	ZF240N30P2A1AAA1A1



GENERAL

Units shall be manufactured by Johnson Controls Unitary Products in an ISO 9001 certified facility.

York Sunline Magnum units are convertible single package units. ZR/ZF models have dual independent refrigerant circuits for efficient part load operation and maximum comfort control. Although the units are primarily designed for curb mounting on a roof, they can also be slab-mounted at ground level or set on steel beams above a finished roof. Cooling only, cooling with gas heat and cooling with electric heat models are available with a wide variety of factory-mounted options and field-installed accessories to make them suitable for almost every application. All units are self-contained and assembled on full perimeter base rails with holes in the four corners for overhead rigging. Every unit is completely piped, wired, charged and tested at the factory to simplify the field installation and to provide years of dependable operation. All models (including those with an economizer) are suitable for either bottom or horizontal duct connections. Models with power exhaust are suitable for bottom duct connections only. For bottom duct, remove the sheet metal panels from the supply and return air openings through the base of the unit. or horizontal duct, replace the supply and return air panels on the rear of the unit with a side duct flange accessory. All supply air blowers are equipped with a belt drive that can be adjusted to meet exact requirements of the job. A high static drive option is available for applications with a higher CFM and/or static pressure requirement.

ZF/XP180 models have 2 condenser fan motors. All compressors include crankcase heat and internal pressure relief. Every refrigerant circuit includes an expansion valve, a liquid line filter-drier, a discharge line high pressure switch and a suction line with a freeze-stat and low pressure/loss of charge switch. The unit control circuit includes a 75 VA transformer, a 24-volt circuit breaker and a relay board with two compressor lockout circuits, a terminal strip for thermostat wiring, plus an additional set of pin connectors to simplify the interface of additional field controls. All units have long lasting powder paint cabinets with 1000 hour salt spray test approval under ASTM-B117 procedures. All models are CSA approved. All models include a 1-year limited warranty on the complete unit. Compressors and electric heater elements carry an additional 4-year warranty. Aluminized steel tubular heat exchangers carry an additional 9-year warranty.

DESCRIPTION

ZF units shall be factory-assembled, single packaged, ZF***N Electric Cooling/Gas Heat, ZF***C/E Electric Cooling/Optional Electric Heat, designed for outdoor

mounted installation. The 20 and 25 ton units shall have a minimum EER rating of 10.

They shall have built-in field convertible duct connections for down discharge supply/return or horizontal discharge supply/ return, and be available with factory installed options or field installed accessories. The units shall be factory wired, piped, charged with R-410A refrigerant and factory tested prior to shipment. All unit wiring shall be both numbered and color coded. All units shall be manufactured in a facility certified to ISO 9001 standards and the cooling performance shall be rated in accordance with DOE and AHRI test procedures. Units shall be CSA listed, classified to ANSIZ21.47 standards, UL 1995/ CAN/CSA No. 236-M90 conditions.

UNIT CABINET

Unit cabinet shall be constructed of galvanized steel, with exterior surfaces coated with a non-chalking, powdered paint finish, certified at 1000 hours salt spray test per ASTM-B117 standards. Indoor blower section shall be insulated with a minimum 1/2" thick insulation, coated on the airside. Aluminum foil faced insulation shall be used in the furnace compartment and be fastened with ridged fasteners to prevent insulation from entering the air stream. Cabinet panels shall be "large" size, easily removable for servicing and maintenance. Full perimeter base rails shall be provided to assure reliable transit of equipment, overhead rigging and proper sealing on roof curb applications. Disposable 2" filters shall be furnished and be accessible through a removable access door, sealed airtight. Units filter track shall be designed to accommodate either 2" or 4" filters. Fan performance measuring ports shall be provided on the outside of the cabinet to allow accurate air measurements of evaporator fan performance without removing panels or creating air by-pass of the coils. Condensate pan shall be internally sloped and conform to ASHRAE 62-89 self-draining standards. Condensate connection shall be a minimum of 1" I.D. female and be a ridged mount connection. Unit shall incorporate a fixed outdoor air damper with an outdoor air intake opening covered with a bird screen and a rain hood painted to match the exterior of the unit.

INDOOR (EVAPORATOR) FAN ASSEMBLY

Fan shall be a belt drive assembly and include an adjustable- pitch motor pulley. Job site selected (B.H.P.) brake horsepower shall not exceed the motors nameplate horsepower rating, plus the service factor. Units shall be designed not to operate above service factor. Fan wheel shall be double-inlet type with forward-curved blades, dynamically balanced to operate smoothly throughout the entire range of operation. Airflow design shall be constant air volume.

IntelliSpeed™ Supply Fan Control Option (ASHRAE 90.1 compliant, section 6.4.3.10) – Units configured with the IntelliSpeed™ Supply Fan Option will contain a VFD

for variable volume supply fan operation. This option allows the supply fan RPM to vary based on the number of compressors or heating stages energized. The economizer's minimum position will also be configurable to vary based on the supply fan VFD frequency output.

OUTDOOR (CONDENSER) FAN ASSEMBLY

The outdoor fans shall be of the direct-driven propeller type, discharge air vertically, have aluminum blades riveted to corrosion resistant steel spider brackets and shall be dynamically balanced for smooth operation. The 4 outdoor fan motors shall be totally enclosed with permanently lubricated bearings, internally protected against overload conditions and staged independently.

REFRIGERANT COMPONENTS

Compressors:

- a. Shall be Scroll compressors internally protected with internal high-pressure relief and over temperature protection.
- b. Shall have internal spring isolation and sound muffling to minimize vibration and noise, and be externally isolated on a dedicated, independent mounting.

Coils:

- a. Evaporator and condenser coils shall have aluminum plate fins mechanically bonded to seamless internally enhanced copper tubes with all joints brazed. Special Phenolic coating shall be available as a factory option
- b. Evaporator and Condenser coils shall be of the direct expansion, draw-thru, design

Refrigerant Circuit and Refrigerant Safety Components shall include:

- Balance-port thermostatic expansion valve with independent circuit feed system.
- Filter drier/strainer to eliminate any moisture or foreign matter.
- Accessible service gage connections on both suction and discharge lines to charge, evacuate, and measure refrigerant pressure during any necessary servicing or troubleshooting, without losing charge.
- The refrigeration system shall provide at least 15° F of sub-cooling at design conditions.

Unit Controls:

- a. Unit shall be complete with self-contained low-voltage control circuit protected by a resettable circuit breaker on the 24-volt transformer side
- b. Unit shall incorporate a lockout circuit which provides reset capability at the space thermostat or base unit, should any of the following standard safety devices trip and shut off compressor
- c. Loss-of-charge/Low-pressure switch. (1) High-pressure switch, (2) Freeze-protection thermostat, evaporator coil. If any of the above safety devices trip, a LED (light-emitting diode) indicator shall flash a diagnostic code that indicates which safety switch has tripped
- d. Unit shall incorporate "AUTO RESET" compressor over temperature, over current protection
- e. Unit shall operate with conventional thermostat designs and have a low voltage terminal strip for easy hook-up
- f. Unit control board shall have on-board diagnostics and fault code display
- g. Standard controls shall include anti-short cycle and low voltage protection, and permit cooling operation down to 0 °F
- h. Control board shall monitor each refrigerant safety switch independently
- i. Control board shall retain last 5 fault codes in non volatile memory, which will not be lost in the event of a power loss

GAS HEATING SECTION

Shall be designed with induced draft combustion with post purge logic and energy saving direct spark ignition, redundant main gas valve. Ventor wheel shall be constructed of stainless steel for corrosion resistance. The heat exchanger shall be of the tubular type, constructed of T1-40 aluminized steel for corrosion resistance and allowing minimum mixed air entering temperature of 25 °F. Burners shall be of the in-shot type, constructed of aluminum coated steel and contain air mixture adjustments. All gas piping shall enter the unit cabinet at a single location through either the side or curb, without any field modifications. An integrated control board shall provide timed control of evaporator fan functioning and burner ignition. Heating section shall be provided with the following minimum protection:

- a. Primary and auxiliary high-temperature limit switches.
- b. Induced draft motor speed sensor.
- c. Flame roll out switch (automatic reset).
- d. Flame proving controls. Unit shall have two independent stages of capacity.



UNIT OPERATING CHARACTERISTICS

Unit shall be capable of starting and running at 125° F outdoor temperature, exceeding maximum load criteria of AHRI Standard 340/360. The compressor, with standard controls, shall be capable of operation down to 25° F outdoor temperature. Accessory low ambient kit shall be available for operation to 0° F. Unit shall be provided with fan time delay to prevent cold air delivery before heat exchanger warms up.

ELECTRICAL REQUIREMENTS

All unit power wiring shall enter unit cabinet at a single factory provided location and be capable of side or bottom entry, to minimize roof penetrations and avoid unit field modifications. Separate side and bottom openings shall be provided for the control wiring.

STANDARD LIMITED WARRANTIES

- Compressor 5 Years
- Heat Exchanger 10 Years
- Electric Heat Element 5 Years
- Other Parts 1 Year

OPTIONAL OUTDOOR AIR

Shall be made available by either/or:

OTHER FACTORY INSTALLED OPTIONS

FIELD INSTALLED OPTIONS

Date

03/19/2018

Project Name

CMS- DOGE 19014

Project Number

Client / Purchaser



Control Summary Page

Control	Models and Unit Tags
Standard Simplicity Control	ZF240N30P2A1AAA1A1

23 09 23 Direct- digital Control system for HVAC23 09 23. 13 Decentralized, Rooftop Units:23 09 23. 13.A. Unit Control Board

1. ASHRAE 62- 2001 compliant. BTL certified.
2. Shall accept 20-30 VAC input power, 50/60Hz. 24 VAC nominal.
3. Operating temperature range from -40F to 158F; 10-90% RH (non-condensing UI), and -4F to 158F; 10-90% Rh (non-condensing), with a storage temperature range from -40F to 194F; 5-95% RH (non-condensing).
4. Shall include an option of and Economizer microprocessor controller which communicates directly with the Unit Control Board and has 8 Analog outputs, 2 Analog inputs, 2 Binary outputs, 3 Binary outputs.
5. Controller shall accept the following inputs: space temperature, return air temperature sensor, setpoint adjustment, outdoor air temperature, indoor air quality, outdoor air quality, indoor relative humidity, compressor lock- out, fire/smoke shutdown, single and dual enthalpy, fan status, remote time clock, SA Bus communicated temperature/humidity/CO2 values from Network sensors, FC Bus Network Overrides for space temperature, outdoor air temperature, space humidity, outdoor air quality, Indoor air quality, System purge.
6. Shall accept a single CO2 sensor or multiple CO2 sensors networked together via communication bus in the conditioned space, and be Demand Control Ventilation (DCV) ready.
7. Shall provide the following outputs: economizer, fan, cooling stage 1, cooling stage 2, heat stage 1, heat stage 2, heat stage 3/ exhaust/ reversing valve/ dehumidify/occupied.
8. Unit shall provide surge protection for the controller through a circuit breaker.
9. Shall be Internet capable, and communicate at a Baud rate of 38.4K or faster.
10. Shall have an LED display independently showing the status of activity on the communication bus, and processor operation.
11. Unit shall incorporate a lockout circuit which provides reset capability at the space thermostat or base unit should any of the following standard safety devices trip and shut off compressor. If any of these safety devices trip, the LCD screen will display alarm message indicating the specific safety device that caused the lockout.
 - a. Loss of charge/Low-pressure switch.
 - b. High-pressure switch.
 - c. Freeze condition sensor on evaporator coil.
12. Unit control board must support each usage case:
 - a. Conventional thermostat with low voltage input terminals for easy installation
 - b. Communicating network sensors in the occupied space to provide feedback on space conditions for unit control board to compare with associated setpoints
 - c. Communication via BACnet MS/TP, Modbus RTU, N2 protocols for integration into a building automation/management system
13. Anti-short cycle and low voltage protection features included.
14. Internal occupied/unoccupied scheduling
15. Unit control board shall permit cooling operation down to a selectable value as low as 0 degrees F.
16. Shall allow for start-up, commissioning, troubleshooting, parameter adjustment, setpoint adjustment via onboard display and navigable menu with no additional interface tool or controls technician required.
17. The unit control board shall run a self-test diagnostics algorithm at startup that operated the cooling cycle, heating cycle, fan operation. A status report shall be provided upon completion of the diagnostic self-test.
18. Utilize any wi-fi enabled smart device to access the HVAC or multiple HVAC units if communication wiring between them is present (FC Bus or SA Bus). Remote access shall allow complete ability to perform start-up, commissioning, troubleshooting, parameter adjustment, setpoint adjustment.
19. Local embedded trending and scheduling. Trending data and occupancy scheduling predefined from the factory. Occupancy schedule to be modified via control board joystick menu navigation and remotely using a smart device (cellular phone, laptop, tablet)
20. A menu on the onboard screen shall display the unit status and allow changing parameters where applicable. These include but are not limited to:
 - a. Demand Ventilation Mode – enable or disable
 - b. Operational Setpoint – display current value
 - c. Supply Air Temperature (SAT) – display current value
 - d. Return Air Temperature (RAT) – display current value

- e. Operational Supply Humidity (OprSH) – display current value as provided by a 0-10VDS input, SA Bus Network Sensor, or FC Bus communicated value
 - f. Return Air Humidity (RAH) – display current value
 - g. Operational outdoor Air Temperature (OprOAT) – enthalpy calculated from OAH 0-10VDC input to Economizer board and OprOAT only if economizer is present
 - h. Operational Outdoor Air Humidity (OprOAH) – the buffered outdoor air humidity. May be from economizer boards OAH 0-10VDC input or FC Bus communicated value
 - i. Operational outdoor Air Quality (OprOAQ) – the buffered outdoor air quality in use. May be from economizer boards OAQ 0-10VDC input or FC Bus communicated value
 - j. Operational Indoor Air Quality (OprIAQ) – the buffered indoor air quality in use. May be from economizer board IAQ 0-10VDC input, SA Bus Network Sensor, or FC Bus communicated value
21. A menu shall display and allow modification to the following operations and settings:
- a. HVAC Zone Fan
 - b. Cooling
 - c. Heating
 - d. Economizer
 - e. Demand Ventilation
 - f. Power Exhaust
 - g. Sensors
 - h. Network
22. A menu shall display and allow modification to the following operations and settings:
- a. HVAC Zone – Occupied status
 - b. Indoor Fan status
 - c. Cooling status
 - d. Heating status
 - e. Economizer indication whether free-cooling is available or not
 - f. Enabling or disabling of Demand Ventilation
 - g. Power Exhaust
 - 1) Enable/disable hot-gas reheat if available
 - 2) Warmup/Cooldown
 - 3) Title 24 Load Shed
 - 4) Defrost
23. A menu shall display and allow modification to the following operations and settings:
- a. Firmware version (of UCB, Economizer, other peripheral boards)
 - b. Setting time zone
 - c. Network information
 - 1) Device name that will appear on the FC Bus
 - 2) Selection of communication protocol
 - 3) Operational Baud Rate
 - 4) Device ID
24. A menu shall display and allow modification to the following operations and settings:
- a. Version of firmware
 - b. Ability to Load new firmware
 - c. Create a backup file of the firmware and parameter setting via USB port
 - d. Restore factory default parameter values and setup
 - e. Full and Partial Cloning of parameter setpoints from or to other units
 - f. Data trend exporting
25. A menu shall display and allow modification to the following operations and settings:

- a. Unit serial number, model number and name
- b. Ability to reset Lockouts
- c. Controller name
- d. Displays the current values of all setpoints in use
- e. Displays all current values for the indoor and outdoor zones
- f. Displays current values related to:
 - 1) Indoor Fan
 - 2) Cooling
 - 3) Heating
 - 4) Heat Pump operation
 - 5) Economizer operation
 - 6) Power Exhaust
 - 7) Demand Ventilation
 - 8) Air monitoring station
 - 9) Hot Gas Reheat
 - 10) Smoke Control
- g. Current information for inputs; including
 - 1) Sensors
 - 2) Coil Sensors
 - 3) Thermostat
 - 4) Binary Inputs
 - 5) Unit Protection
 - 6) Network Inputs
 - 7) All outputs (relay and binary)
- h. Self-Test
 - 1) A patented self-test system that runs through a series of algorithms to provide a report of all functioning characteristics of the system at time of startup and commissioning.

23 09 23. 13.B. Auxiliary Control Boards

1. ASHRAE 62- 2001 compliant. BTL certified.
2. Economizer controller CEC Title 24 Compliant
 - a. Display alarms if the following occur
 - 1) Economizer is economizing when conditions do not support
 - 2) Economizer is not economizing when conditions do support
 - 3) Damper Stuck
 - 4) Excess Outdoor Air
 - 5) Failed Sensor
3. Refrigeration Fault Detection & Diagnostics
 - a. There is insufficient refrigerant in any circuit
 - b. There is excessive refrigerant in any circuit
 - c. There is excessive refrigerant flow
 - d. There is insufficient refrigerant flow (restriction)
 - e. Inefficient compressor
 - f. Insufficient High-side heat transfer
 - g. Excessive High-side heat transfer (low ambient control problem, low ΔP)
 - h. Insufficient Low-side heat transfer
 - i. Excessive Low-side heat transfer

- j. Sensor fault- The liquid temperature is greater than the condenser temperature (Could also be triggered if refrigerant level is very low in the system)
- k. Sensor fault- Sensor data is not available
- l. The unit is off
- m. The ambient temperature is too low
- n. The ambient temperature is too high
- o. The return air wet-bulb temperature is too low
- p. The return air wet-bulb temperature is too high
- q. Sensor fault- The condensing temperature is lower than the ambient temperature (Could also be triggered when the condenser is wet)
- r. The suction line temperature is less than the evaporator temperature
- s. The evaporator temperature is greater than the ambient temperature
- t. The liquid temperature is lower than the ambient temperature
- u. Sensor fault- Suction temperature or ambient temperature is invalid
- v. Sensor fault- The return air dry-bulb or wet-bulb temperature is invalid
- w. Sensor fault- The liquid pressure or suction pressure is invalid
- x. Sensor fault- The suction line temperature is invalid
- y. The return air dry-bulb temperature is too low
- z. The return air dry-bulb temperature is too high
- aa. The Efficiency Index is below 75% of ideal
- bb. The Capacity Index is below 75% of ideal

23 09 23. 13.C Remote Accessibility:

1. ASHRAE 62- 2001 compliant. BTL certified.
2. Provide the ability to adjust parameter values, setpoints, limits remotely
3. Connectivity to an Ethernet network via static IP address or Dynamic Name Server (DNS)
4. Allow a maximum of 100 devices on the same FC bus trunk and accessed by one remote device

START-UP & SERVICE DATA INSTRUCTION

COMMERCIAL PACKAGE UNITS

3.0 To 40.0 TONS

START-UP CHECKLIST

Date: _____

Job Name: _____

Customer Name: _____

Address: _____

City: _____ State: _____ Zip: _____

Model Number: _____ Serial Number: _____

Qualified Start-up Technician: _____ Signature: _____

HVAC Contractor: _____ Phone: _____

Address: _____

Contractor's E-mail Address: _____

Electrical Contractor: _____ Phone: _____

Distributor Name: _____ Phone: _____

WARRANTY STATEMENT

Johnson Controls/UPG is confident that this equipment will operate to the owner's satisfaction if the proper procedures are followed and checks are made at initial start-up. This confidence is supported by the 30 day dealer protection coverage portion of our standard warranty policy which states that Johnson Controls/UPG will cover parts and labor on new equipment start-up failures that are caused by a defect in factory workmanship or material, for a period of 30 days from installation. Refer to current standard warranty policy and warranty manual found on UPGnet for details.

In the event that communication with Johnson Controls/UPG is required regarding technical and/or warranty concerns, all parties to the discussion should have a copy of the equipment start-up sheet for reference. A copy of the original start-up sheet should be filed with the Technical Services Department.

The packaged unit is available in constant or variable air volume versions with a large variety of custom options and accessories available. Therefore, some variation in the startup procedure will exist depending upon the products capacity, control system, options and accessories installed.

This start-up sheet covers all startup check points common to all package equipment. In addition it covers essential startup check points for a number of common installation options. Depending upon the particular unit being started not all sections of this startup sheet will apply. Complete those sections applicable and use the notes section to record any additional information pertinent to your particular installation.

Warranty claims are to be made through the distributor from whom the equipment was purchased.

EQUIPMENT STARTUP

Use the local LCD or Mobile Access Portal (MAP) Gateway to complete the start-up.

A copy of the completed start-up sheet should be kept on file by the distributor providing the equipment and a copy sent to:

Johnson Controls/UPG
Technical Services Department
5005 York Drive
Norman, OK 73069

SAFETY WARNINGS

The inspections and recording of data outlined in this procedure are required for start-up of Johnson Controls/UPG's packaged products. Industry recognized safety standards and practices must be observed at all times. General industry knowledge and experience are required to assure technician safety. It is the responsibility of the technician to assess all potential dangers and take all steps warranted to perform the work in a safe manner. By addressing those potential dangers, prior to beginning any work, the technician can perform the work in a safe manner with minimal risk of injury.

▲WARNING
Lethal voltages are present during some start-up checks. Extreme caution must be used at all times.

▲WARNING
Moving parts may be exposed during some startup checks. Extreme caution must be used at all times.

NOTE: Read and review this entire document before beginning any of the startup procedures.

DESIGN APPLICATION INFORMATION

This information will be available from the specifying engineer who selected the equipment. If the system is a VAV system the CFM will be the airflow when the remote VAV boxes are in the

full open position and the frequency drive is operating at 60 HZ. **Do not proceed with the equipment start-up without the design CFM information.**

Design Supply Air CFM: _____ Design Return Air CFM: _____

Design Outdoor Air CFM At Minimum Position: _____

Total External Static Pressure: _____

Supply Static Pressure: _____

Return Static Pressure: _____

Design Building Static Pressure: _____

Outside Air Dilution: Economizer Position Percentage: _____ CFM: _____

Supply Gas Pressure After Regulator W/o Heat Active _____ Inches _____

ADDITIONAL APPLICATION NOTES FROM SPECIFYING ENGINEER:

REFERENCE

General Inspection	Completed	See Notes
Unit inspected for shipping, storage, or rigging damage	<input type="checkbox"/>	<input type="checkbox"/>
Unit installed with proper clearances	<input type="checkbox"/>	<input type="checkbox"/>
Unit installed within slope limitations	<input type="checkbox"/>	<input type="checkbox"/>
Refrigeration system checked for gross leaks (presence of oil)	<input type="checkbox"/>	<input type="checkbox"/>
Terminal screws and wiring connections checked for tightness	<input type="checkbox"/>	<input type="checkbox"/>
Filters installed correctly and clean	<input type="checkbox"/>	<input type="checkbox"/>
Economizer hoods installed in operating position	<input type="checkbox"/>	<input type="checkbox"/>
Condensate drain trapped properly, refer to Installation Manual	<input type="checkbox"/>	<input type="checkbox"/>
Economizer damper linkage tight	<input type="checkbox"/>	<input type="checkbox"/>
Gas Heat vent hood installed	<input type="checkbox"/>	<input type="checkbox"/>
All field wiring (power and control) complete	<input type="checkbox"/>	<input type="checkbox"/>

Air Moving Inspection	Completed	See Notes
Alignment of drive components	<input type="checkbox"/>	<input type="checkbox"/>
Belt tension adjusted properly	<input type="checkbox"/>	<input type="checkbox"/>
Blower pulleys tight on shaft, bearing set screws tight, wheel tight to shaft	<input type="checkbox"/>	<input type="checkbox"/>
Pressure switch or transducer tubing installed properly	<input type="checkbox"/>	<input type="checkbox"/>

Exhaust Inspection	Powered <input type="checkbox"/>	Barometric Relief <input type="checkbox"/>	Completed	See Notes
Check hub for tightness			<input type="checkbox"/>	<input type="checkbox"/>
Check fan blade for clearance			<input type="checkbox"/>	<input type="checkbox"/>
Check for proper rotation			<input type="checkbox"/>	<input type="checkbox"/>
Check for proper mounting (screen faces towards unit)			<input type="checkbox"/>	<input type="checkbox"/>
Prove operation by increasing minimum setting on economizer			<input type="checkbox"/>	<input type="checkbox"/>

Economizer Inspection	Standard <input type="checkbox"/>	BAS <input type="checkbox"/>	Completed	See Notes
CO ₂ sensor installed Yes <input type="checkbox"/> No <input type="checkbox"/>			<input type="checkbox"/>	<input type="checkbox"/>
Check economizer setting (Reference SSE Control Board LCD menu location)			<input type="checkbox"/>	<input type="checkbox"/>
Prove economizer open/close through SSE Board Setting			<input type="checkbox"/>	<input type="checkbox"/>

Reheat Mode	Normal <input type="checkbox"/>	or Alternate <input type="checkbox"/>	Not Applicable <input type="checkbox"/>
Humidity Sensor (2SH0401) _____			

Operating Measurements - Air Flow

Fan operates with proper rotation	ID Fans <input type="checkbox"/>	Exh. Fans <input type="checkbox"/>	Cond. Fans <input type="checkbox"/>
Pressure drop across dry evaporator coil (At maximum design CFM) ¹			
External Static Pressure	IWC		
Return Static Pressure	IWC		
Supply Static Pressure	IWC		
Supply Air CFM Using Dry Coil Chart	CFM		
Final Adjusted Supply Air CFM ²	CFM		

1. Consult the proper airflow to pressure drop table to obtain the actual airflow at the measured pressure differential.
2. Was a motor pulley adjustment or change required to obtain the correct airflow?
 Was it necessary to increase or decrease the airflow to meet the design conditions?
 If the motor pulley size was changed, measure the outside diameters of the motor and blower pulleys and record those diameters here;

Blower Motor HP _____ FLA _____ RPM _____

Pulley Pitch Diameter _____ Turns Out _____ Final Turns Out _____

Blower Pulley Pitch Diameter _____ Fixed Sheave _____

ELECTRICAL DATA

T1 - T2 _____ Volts T2 - T3 _____ Volts

Control Voltage _____ Volts T1 - T3 _____ Volts

Device	Nameplate	Measured List All Three Amperages
Supply Fan Motor ^{1, 2}	AMPS	AMPS
Exhaust Motor (Dampers 100%)	AMPS	AMPS
Condenser Fan #1	AMPS	AMPS
Condenser Fan #2 (if equipped)	AMPS	AMPS
Condenser Fan #3 (if equipped)	AMPS	AMPS
Condenser Fan #4 (if equipped)	AMPS	AMPS
Compressor #1	AMPS	AMPS
Compressor #2 (if equipped)	AMPS	AMPS
Compressor #3 (if equipped)	AMPS	AMPS
Compressor #4 (if equipped)	AMPS	AMPS

1. VAV units with heat section - simulate heat call to drive VAV boxes and VFD/IGV to maximum design airflow position.
2. VAV units without heat section - VAV boxes must be set to maximum design airflow position.

OPERATING MEASUREMENTS - COOLING

Stage	Discharge Pressure	Discharge Temp.	Liquid Line Temp. ¹	Subcooling ²	Suction Pressure	Suction Temp.	Superheat
First	#	°	°	°	#	°	°
Second (if equipped)	#	°	°	°	#	°	°
Third (if equipped)	#	°	°	°	#	°	°
Fourth (if equipped)	#	°	°	°	#	°	°
Reheat 1st Stage	#	°	°	°	#	°	°

1. Liquid temperature should be taken before filter/drier.
2. Subtract 10 psi from discharge pressure for estimated liquid line pressure

Outside air temperature _____ °F db _____ °F wb _____ %RH
 Return Air Temperature _____ °F db _____ °F wb _____ %RH
 Mixed Air Temperature _____ °F db _____ °F wb _____ %RH
 Supply Air Temperature _____ °F db _____ °F wb _____ %RH

REFRIGERANT SAFETIES

Action	Completed	See Notes
Prove Compressor Rotation (3 phase only) by gauge pressure	<input type="checkbox"/>	<input type="checkbox"/>
Prove High Pressure Safety, All Systems	<input type="checkbox"/>	<input type="checkbox"/>
Prove Low Pressure Safety, All Systems	<input type="checkbox"/>	<input type="checkbox"/>

OPERATING MEASUREMENTS - GAS HEATING

Fuel Type: Natural Gas LP Gas

Action	Completed	See Notes
Check for gas leaks	<input type="checkbox"/>	<input type="checkbox"/>
Prove Ventor Motor Operation	<input type="checkbox"/>	<input type="checkbox"/>
Prove Primary Safety Operation	<input type="checkbox"/>	<input type="checkbox"/>
Prove Auxiliary Safety Operation	<input type="checkbox"/>	<input type="checkbox"/>
Prove Rollout Switch Operation	<input type="checkbox"/>	<input type="checkbox"/>
Prove Smoke Detector Operation	<input type="checkbox"/>	<input type="checkbox"/>
Manifold Pressure	Stage 1	IWC <input type="checkbox"/>
	Stage 2 (If Equipped)	IWC <input type="checkbox"/>
	Stage 3 (If Equipped)	IWC <input type="checkbox"/>
Supply gas pressure at full fire	IWC	<input type="checkbox"/>
Check temperature rise ¹	<input type="checkbox"/> measured at full fire	°F <input type="checkbox"/>

1. Input X Eff. (BTU output)
1.08 X Temp. Rise

OPERATIONAL MEASUREMENTS - STAGING CONTROLS

Verify Proper Operation of Heating/Cooling Staging Controls	
Create a cooling demand at the Thermostat, BAS System or Simplicity SE Verify that cooling/economizer stages are energized.	<input type="checkbox"/>
Create a heating demand at the Thermostat, BAS System or Simplicity SE Verify that heating stages are energized.	<input type="checkbox"/>
Verify Proper Operation of the Variable Frequency Drive (If Required)	
Verify that motor speed modulates with duct pressure change.	<input type="checkbox"/>

FINAL - INSPECTION

Verify that all operational control set points have been set to desired value Scroll through all setpoints and change as may be necessary to suit the occupant requirements.	<input type="checkbox"/>
Verify that all option parameters are correct Scroll through all option parameters and ensure that all installed options are enabled in the software and all others are disabled in the software. (Factory software settings should match the installed options)	<input type="checkbox"/>
Verify that all access panels have been closed and secured	<input type="checkbox"/>

OBSERVED PRODUCT DIFFICIENCIES & CONCERNS:
