

# Historic Preservation Commission Meeting November 7, 2011



- Good Afternoon!  
Please sign in at the door
- If you wish to speak on an issue or have your opinion noted by the commission, please fill out a form at the door and hand it to us



— *M*ILWAUKEE —

**HISTORIC  
PRESERVATION  
COMMISSION**

---

LIVING WITH HISTORY

1230 E. Brady St.

*New Storefront*

**Brady Street Historic  
District**





REF  
SURROUND  
REF  
F  
F  
REMOVE SIGN COMP  
INCLUDING SUUPPOR  
ELECTRICAL CONNE  
REPAIR

REMOVE FABRIC AL  
AND FRAMINGS COM

REMOVE WINDOW CO

REMOVE APPLIED WO  
REMOVE ADHESIVE A

REMOVE BRICK VEN  
VERIFY SUBSTRATE  
BACK UP



**2** SOUTH ELEVATION  
 Scale: 1/4"=1'-0"

Proposed new storefront

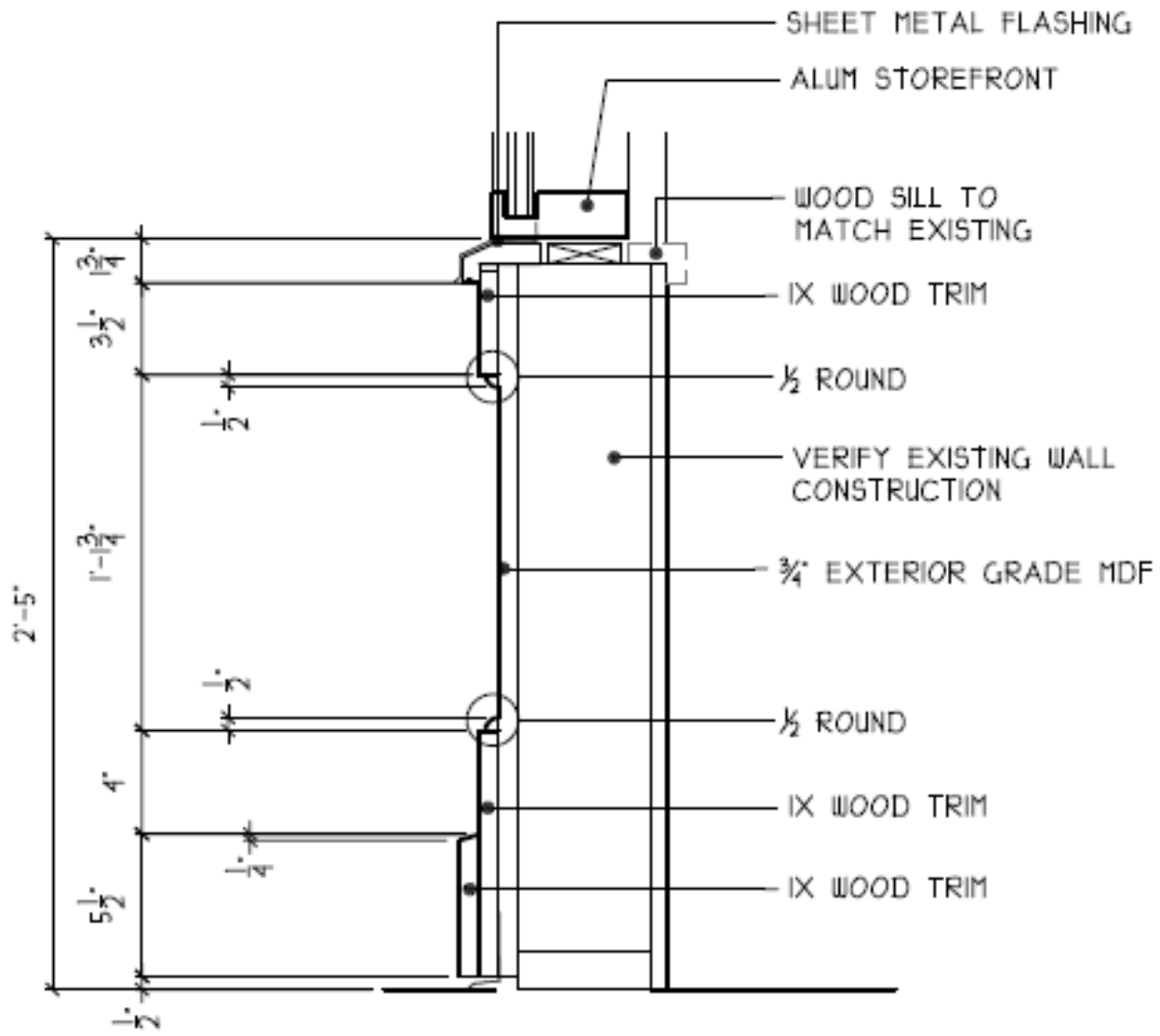

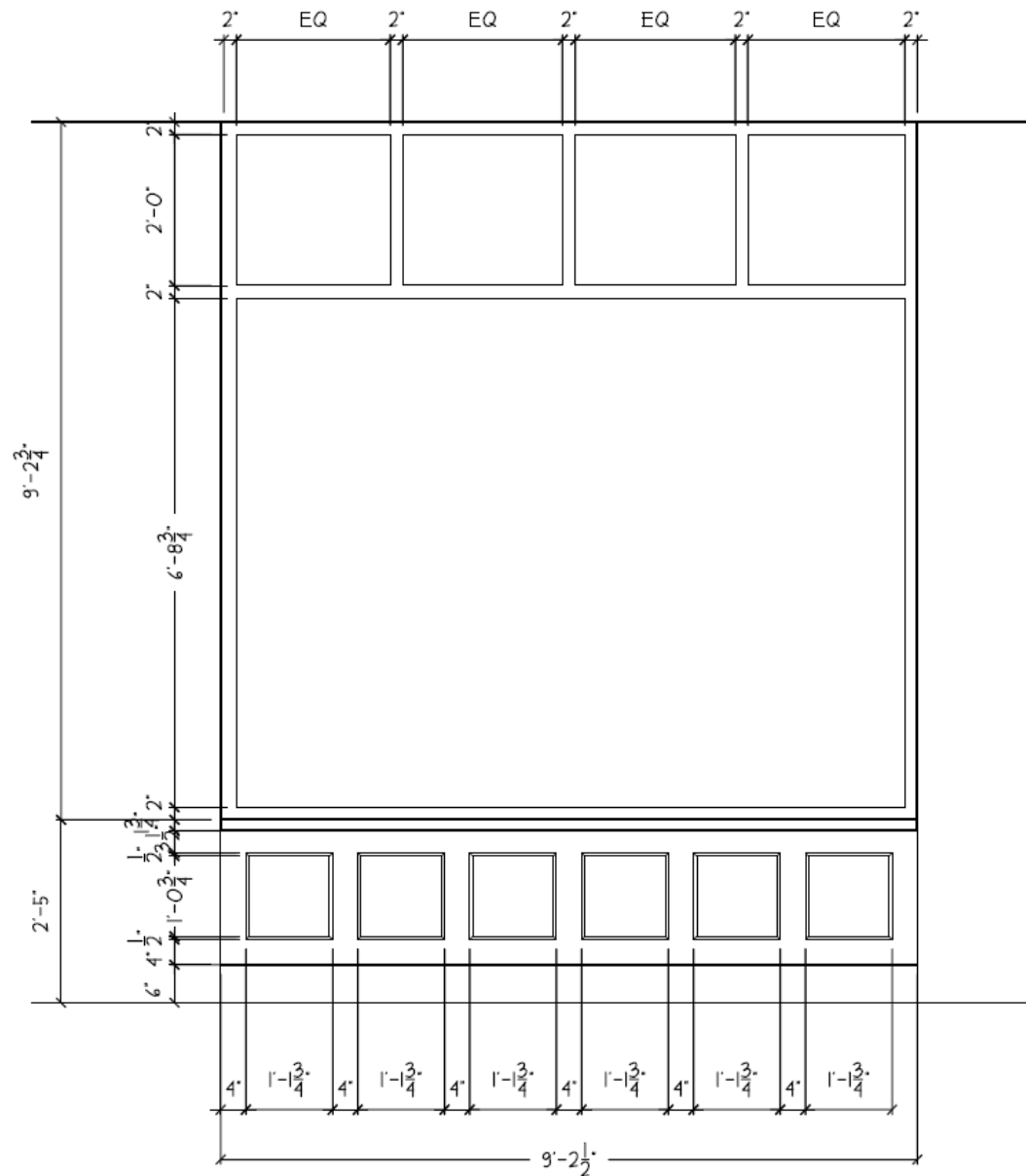

Elevation  
of new  
storefront  
window