



Certificate of Appropriateness

Milwaukee Historic Preservation Commission/200 E. Wells Street/Milwaukee, WI 53202/phone 414-286-5712/

Property
Description of work
Date issued

743 N. Water Street

First National / First Wisconsin Bank

Replace signage per attached documents on the following NINE PAGES. Sizes may be reduced to comply with zoning requirements without further HPC review.

10/24/22

PTS ID N/A

In accordance with the provisions of Section 320-21 (11) and (12) of the Milwaukee Code of Ordinances, the Milwaukee Historic Preservation Commission has issued a certificate of appropriateness for the work listed above. The work was found to be consistent with preservation guidelines. The following conditions apply to this certificate of appropriateness:

All work must be done in a craftsman-like manner, and must be completed within one year of the date this certificate was issued. Staff must approve any changes or additions to this certificate before work begins. Work that is not completed in accordance with this certificate may be subject to correction orders or citations. If you require technical assistance, please contact Historic Preservation staff as follows: Phone: (414) 286-5712 E-mail: hpc@milwaukee.gov.

If permits are required, you are responsible for obtaining them from the Milwaukee Development Center. If you have questions about permit requirements, please consult the Development Center's web site, www.milwaukee.gov/lms, or call (414) 286-8210.

City of Milwaukee Historic Preservation

Copies to: Development Center, Ald. R. Bauman

EXISTING SIGN SF:	4
PROPOSED SIGN SF:	4

±10'-0"
Install Centered
@ Same Location
As Existing



Existing 8" h x 6'-0" w sign to be removed & replaced. Wall patched and painted as required.

Install Centered
@ Same Location
As Existing

CLIENT:	CIBC	ORDER NUMBER:	1164642	PROJECT NUMBER:	4769
ADDRESS:	743 N. Water St. Milwaukee, WI 53202-4101	SITE NUMBER:	343	PROJECT MANAGER:	BILL DESTEFANO
PAGE NO.:	3	ELECTRONIC FILE NAME:	K:\ACCOUNTS\CIBC\LOCATIONS\SIG22\WIN		
			343_Milwaukee043_Milwaukee_RL.dwg		

StratusTM

stratusunlimited.com
8989 Tyler Boulevard
Mentor, Ohio 44060
888.503.1569

Rev #	Req #	Date/Artist	Description	Rev #	Req #	Date/Artist	Description
Original	370257	03/07/21 CR					
Rev 1	380151	04/26/21 CR	Removed w/line from logo. Non-illuminated sign				
Rev 2	400739	09/19/21 TC					
Rev 3	401857	09/28/21 CR					
Rev 4	404538	10/17/21 TC	Add measurements				

PRINT AS THE EXCLUSIVE PROPERTY OF STRATUS. THE MATERIAL SHALL NOT BE USED, DUPLICATED, OR OTHERWISE REPRODUCED WITHOUT THE PRIOR WRITTEN CONSENT OF STRATUS.

EXISTING SIGN SF:	4
PROPOSED SIGN SF:	4



Existing 8" x 6'-0" sign to be removed & replaced. Wall patched and painted as required.



±10'-0"
Install Centered @ Same Location As Existing

±9"
Install Centered @ Same Location As Existing



stratusunlimited.com
8959 Tyler Boulevard
Mentor, Ohio 44060
888.503.1569

CLIENT:	CIBCO	PROJECT NUMBER:	4769
ADDRESS:	743 N. Weber St. Milwaukee, WI 53202-4101	SITE NUMBER:	343
PAGE NO.:	4	ELECTRONIC FILE NAME:	K:\ACCOUNTS\CIBCO\LOCATIONS\2022\343_Milwaukee\343_Milwaukee_R4.cdr
ORDER NUMBER:	1164842	PROJECT MANAGER:	BILL DESTEFANO

Rev #	Rev #	Date/Artist	Description	Rev #	Rev #	Date/Artist	Description
Original	3/04/57	03/31/22CR					
Rev 1	3/30/57	04/26/22CR	Removed logo from logo. Non-laminated sign				
Rev 2	4/01/59	03/19/22TC					
Rev 3	4/01/57	03/28/22CR					
Rev 4	4/04/53	10/17/22TC					

NOT TO SCALE. THE EXISTING ELEVATION OF THE SITE IS ESTIMATED AND MAY NOT BE IDENTICAL TO THE EXISTING PHOTO. CONDITIONS SHOWN ARE FOR INFORMATION ONLY.

NON-ILLUM. PAN SIGN W/ PLATE LOGO

CUSTOM

Scale: 1-1/2"=1'-0"

4 square feet

E1

E2

LETTERS:

1/4" thick aluminum plate letters painted white w/ grey vinyl overlay for logo as shown.

BACKER:

3" deep pan formed .080 alum. backer with internal alum angle framework - all exposed surfaces painted Red

INSTALL:

Letters stud mounted flush to backer. Backer to be thru bolted flush to interior wall using internal clips and threaded rod as required. No visible fasteners.

QUANTITY:

(2) TWO Required

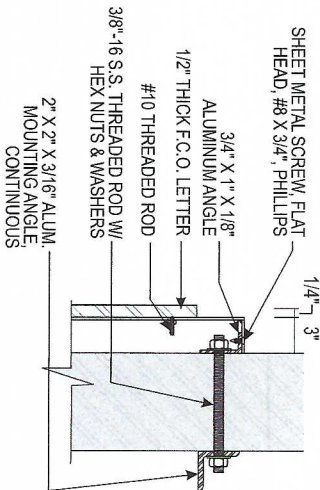
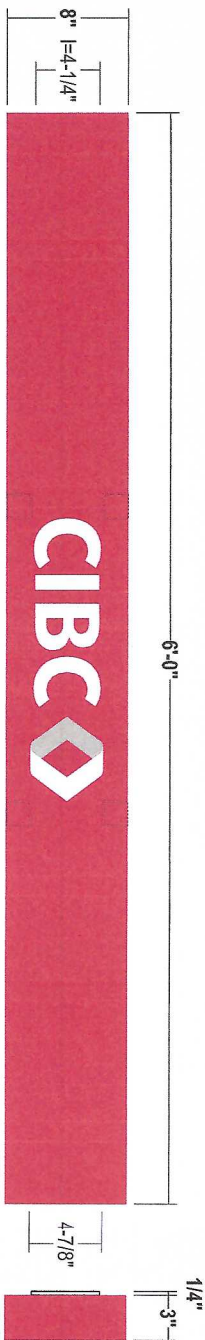

COLOR PALETTE

- PANEL:** Paint to match PMS 7638 C
- LETTERS & LOGO:** White
- LOGO:** 3M 3730-0387 CIBC Grey

CLIENT:	CIBCO	ORDER NUMBER:	1164642	PROJECT NUMBER:	4769
ADDRESS:	743 N. Water St Milwaukee, WI 53202-4101	SITE NUMBER:	343	PROJECT MANAGER:	BILL DESTEFANO
PAGE NO.:	5	ELECTRONIC FILE NAME:	K:\ACCOUNTS\CIBCO\LOCATIONS\022\WI 343_Milwaukee\343_Milwaukee_P4.cdr		

Rev #	Rev #	Date/Artist	Description	Rev #	Rev #	Date/Artist	Description
Original	370657	03/07/21CR					
Rev 1	380151	04/28/21CR	Removed letters from logo. Non-illuminated sign				
Rev 2	400739	09/19/21TC					
Rev 3	401657	09/29/21CR					
Rev 4	404538	10/17/21TC					

StratusTM

stratusunlimited.com

888.717.8474
888.503.1569

888.717.8474
888.503.1569

PRINTED IN THE USA BY WESTERN SIGN COMPANY. THE MATERIALS SHOWN ARE APPROXIMATE. ALL DIMENSIONS ARE IN INCHES UNLESS OTHERWISE SPECIFIED. © 2021

EXISTING SIGN SF:	13.2
PROPOSED SIGN SF:	13.2

Scale: 1"=1'-0"

13.2 square feet

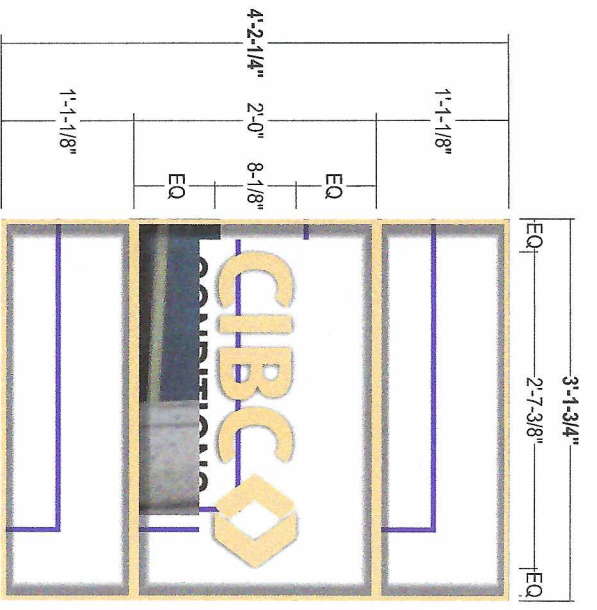

COLOR PALETTE

- Durandonic Bronze Finish
- Polished Bronze

SINGLE LINE BEVEL BORDER

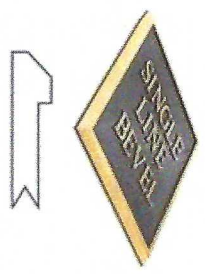

POLISHED BRONZE COPY & BORDER



SECTION DETAIL

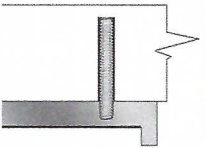

PEBBLE FINISH



EXISTING SIGNAGE TO BE REMOVED & REPLACED WALL TO BE REPAIRED AS REQUIRED

PROPOSED SIGNAGE



- CONSTRUCTION:** 5/16" Thick plaque with standard pebble texture, Durandonic Bronze finish w/ satin clear coat
- COPY & BORDER:** Raised from background w/ polished Bronze finish; 1/2" Border to be single line bevel
- INSTALL:** Plaque to be blind stud mounted to wall; Back of plaque to be drilled & tapped to receive threaded studs
- QUANTITY:** (1) ONE Set of (3) THREE Plaques required

StratusTM
stratusunlimited.com
8859 Tyler Boulevard
Menomonee Falls, WI 53051
888.503.11569

CLIENT	
ADDRESS	743 N. Water St. Milwaukee, WI 53202-4101
PAGE NO.	6
ORDER NUMBER	1164642
PROJECT NUMBER	4769
SITE NUMBER	343
PROJECT MANAGER	BILL DESTEFANO
ELECTRONIC FILE NAME	K:\ACCOUNTS\CIBCO\LOCATIONS\2022\W11343_Milwaukee\343_Milwaukee_R4.dwg

Rev #	Req #	Date/Artist	Description	Rev #	Req #	Date/Artist	Description
Original	37045	03/07/22 CR					
Rev 1	38015	04/06/22 CR	Updated to single-color logo and lettering				
Rev 2	40073	09/19/22 TC					
Rev 3	40160	09/28/22 CR					
Rev 4	40458	10/17/22 TC					

PRINTS ARE THE PROPERTY OF STRATUS UNLIMITED. NO PART OF THIS DOCUMENT IS TO BE REPRODUCED OR TRANSMITTED IN ANY FORM OR BY ANY MEANS, ELECTRONIC OR MECHANICAL, WITHOUT PERMISSION IN WRITING FROM STRATUS UNLIMITED.

EXISTING SIGN SF:	13.2
PROPOSED SIGN SF:	13.2



EXISTING SIGNAGE TO BE REMOVED & REPLACED WALL TO BE REPAIRED AS REQUIRED

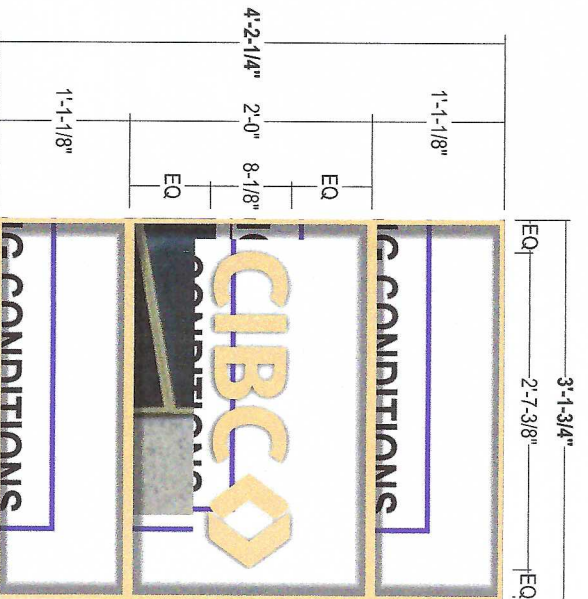

COLOR PALETTE

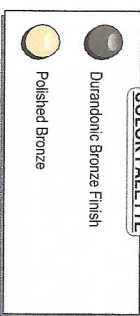

SINGLE LINE BEVEL BORDER

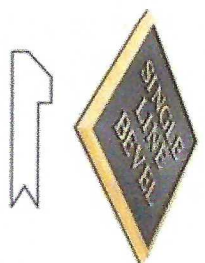

POLISHED BRONZE COPY & BORDER



PEBBLE FINISH



SECTION DETAIL

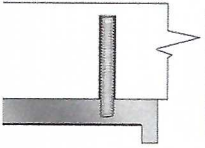

PROPOSED SIGNAGE



CONSTRUCTION: 5/16" Thick plaque with standard pebble texture; Durandonic Bronze finish w/ satin clear coat

COPY & BORDER: Raised from background w/ polished Bronze finish; 1/2" Border to be single line bevel

INSTALL: Plaque to be blind stud mounted to wall; Back of plaque to be drilled & tapped to receive threaded studs

QUANTITY: (1) ONE Set of (3) THREE Plaques required

StratusTM
stratusunlimited.com
8999 Tyler Boulevard
Mentor, Ohio 44060
888-508-1569

CLIENT:	CIBCO	ORDER NUMBER:	1164642	PROJECT NUMBER:	4769
ADDRESS:	743 N. Water St Milwaukee, WI 53202-4101	SITE NUMBER:	343	PROJECT MANAGER:	BILL DESTEFANO
PAGE NO.:	8	ELECTRONIC FILE NAME:	KAACOUNTS/CIBCO/LOCATIONS/0222/WI/343_Milwaukee/543_Milwaukee_Rx.dwg	BILL DESTEFANO	

Rev #	Req #	Date/Artist	Description	Rev #	Req #	Date/Artist	Description
Original	37057	03/01/22	CR				
Rev 1	380151	04/28/22	CR	Updated to single-color logo, no keyline			
Rev 2	400729	09/19/22	TC				
Rev 3	401657	09/29/22	CR				
Rev 4	404538	10/17/22	TC				

THIS DRAWING IS THE PROPERTY OF STRATUS UNLIMITED. IT IS TO BE USED ONLY FOR THE PROJECT AND SITE SPECIFICALLY IDENTIFIED HEREIN. IT IS TO BE KEPT IN STRICTLY CONFIDENTIAL AND NOT TO BE REPRODUCED OR TRANSMITTED IN ANY FORM OR BY ANY MEANS, ELECTRONIC OR MECHANICAL, INCLUDING PHOTOCOPYING, RECORDING, OR BY ANY INFORMATION STORAGE AND RETRIEVAL SYSTEM.

EXISTING SIGN SF:	13.2
PROPOSED SIGN SF:	13.2

TEMPORARY SIGN

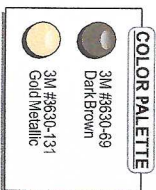
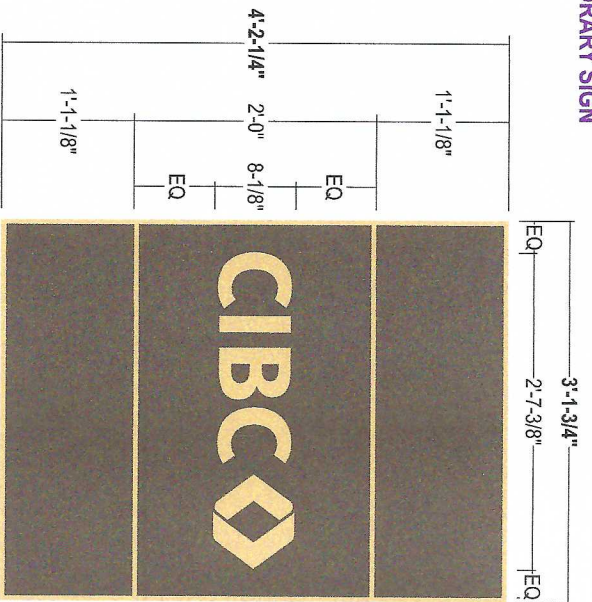

EXISTING SIGNAGE TO BE REMOVED & REPLACED WALL TO BE REPAIRED AS REQUIRED



PROPOSED SIGNAGE



- PANELS:** 3mm White Sintra
- GRAPHICS:** Surface applied digitally printed graphics to match colors shown
- INSTALL:** Mount flush to wall in same location as existing using D/F tape and silicone adhesive
- QUANTITY:** (1) ONE Panel required
- NOTE:** Temporary signage

stratusunlimited.com
8959 Tyler Boulevard
Mentor, Ohio 44060
888.503.1569

CLIENT: **CIBCO**

ADDRESS: 743 N. Water St.
Milwaukee, WI 53202-4101

PAGE NO.: 9

ORDER NUMBER: 1164642 PROJECT NUMBER: 4769

SITE NUMBER: 343 PROJECT MANAGER: BILL DESTEFANO

ELECTRONIC FILE NAME: K:\ACCOUNTS\CIBCO\LOCATIONS\3222\MW 343_Milwaukee\343_Milwaukee_R4.cdr

Rev #	Req #	Date/Artist	Description	Rev #	Req #	Date/Artist	Description
Original	370457	03/07/22CR					
Rev 1	380151	04/28/22CR					
Rev 2	400739	05/19/22TC	Temporary panel design added				
Rev 3	401857	06/28/22CR					
Rev 4	404538	10/17/22TC					

DO NOT SCALE THE EXISTING SIGNAGE OR PROPOSED SIGNAGE. THE PROPOSED SIGNAGE SHOULD BE SIZED ACCORDING TO THE ORIGINAL SIGNAGE. SEE THE EXISTING SIGNAGE FOR SIZES.

EXISTING SIGN SF:	6.3
PROPOSED SIGN SF:	6.3



EXISTING SIGNAGE TO BE REMOVED & REPLACED WALL TO BE REPAIRED AS REQUIRED

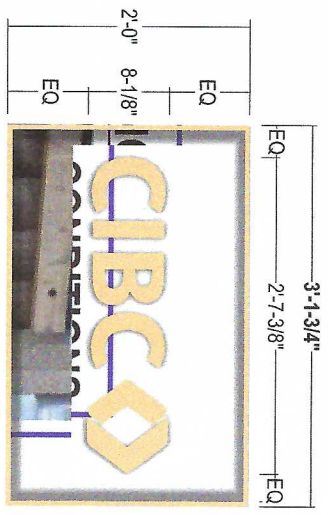

COLOR PALETTE

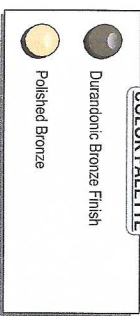

SINGLE LINE BEVEL BORDER

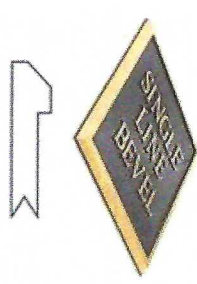

POLISHED BRONZE COPY & BORDER



PEBBLE FINISH



SECTION DETAIL

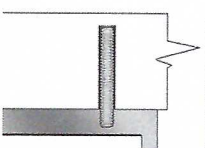

CONSTRUCTION: 5/16" Thick plaque with standard pebble texture; Duranodic Bronze finish w/ satin clear coat

COPY & BORDER: Raised from background w/ polished Bronze finish; 1/2" Border to be single line bevel

INSTALL: Plaque to be blind stud mounted to wall; Back of plaque to be drilled & tapped to receive threaded studs

QUANTITY: (1) ONE Plaque required

PROPOSED SIGNAGE



StratusTM

stratusunlimited.com
8959 Tyler Boulevard
Mentor, Ohio 44060
888.503.1569

CLIENT:	CIBCO
ADDRESS:	743 N. Water St. Milwaukee, WI 53202-4101
PAGE NO.:	10
ORDER NUMBER:	1164642
PROJECT NUMBER:	4769
SITE NUMBER:	343
PROJECT MANAGER:	BILL DESTEFANO
ELECTRONIC FILE NAME:	K:\ACCOUNTS\CIBCO\LOCATIONS\222\22\MI\343_Milwaukee\343_Milwaukee_R4.cdr

Rev #	Req #	Date/Artist	Description	Rev #	Req #	Date/Artist	Description
Original	37057	03/07/22 CR					
Rev 1	38051	04/26/22 CR	Updated to single-color logo, no keyline				
Rev 2	40079	09/19/22 CR					
Rev 3	40187	09/28/22 CR					
Rev 4	40493	10/17/22 TC					

THIS DRAWING IS THE PROPERTY OF STRATUS UNLIMITED. IT IS TO BE USED ONLY FOR THE PROJECT AND SITE SPECIFICALLY IDENTIFIED HEREIN. IT IS TO BE RETURNED TO STRATUS UNLIMITED UPON COMPLETION OF THE PROJECT.

E5

S/F SINTRIA PANEL

Scale: 1"=1'-0"

TEMPORARY SIGN

CUSTOM

6.3 square feet

EXISTING SIGN SF:

6.3

PROPOSED SIGN SF:

6.3

EXISTING

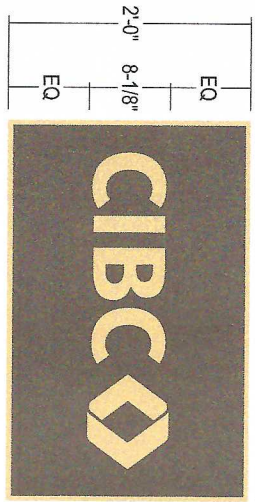
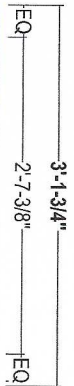

COLOR PALETTE

- 3M #3630-69 Dark Brown
- 3M #3630-131 Gold Metallic

EXISTING SIGNAGE TO BE REMOVED FROM WALL TO BE REPAIRED AS NECESSARY

PROPOSED

- PANELS:** 3mm White Sintria
- GRAPHICS:** Surface applied digitally printed graphics to match colors shown
- INSTALL:** Mount flush to wall in same location as existing using D/F tape and silicone adhesive
- QUANTITY:** (1) ONE Panel required
- NOTE:** Temporary signage

stratusunlimited.com
8959 Tyler Boulevard
Mentor, Ohio 44060
888.503.1569

CLIENT:	
ADDRESS:	743 N. Water St. Milwaukee, WI 53202-4101
PAGE NO.:	11
ORDER NUMBER:	1164642
PROJECT NUMBER:	4769
SITE NUMBER:	343
PROJECT MANAGER:	BILL DESTEFANO
ELECTRONIC FILE NAME:	K:\ACCOUNTS\CIBCO\LOCATIONS\2022\MW\343_Milwaukee\343_Milwaukee_TJ.cdr

Rev #	Req #	Date/Artist	Description	Rev #	Req #	Date/Artist	Description
Original	37057	03/07/22 CR					
Rev 1	380151	04/26/22 CR					
Rev 2	400739	09/19/22 TC					
Rev 3	401857	09/28/22 CR	Temporary panel large added				
Rev 4	404538	10/17/22 TC					

PRINTED IN POLY-UV. SCHEMATIC DRAWING IS INTENDED FOR VISUALIZATION ONLY. NOT FOR CONSTRUCTION. DO NOT REMOVE SIGN OR WITHOUT THE APPROVAL OF THE DESIGNER.

