

1 WEST ELEVATION
1/8" = 1'-0"



2 SOUTH ELEVATION
1/8" = 1'-0"



3 NORTH ELEVATION
1/8" = 1'-0"



4 EAST ELEVATION
1/8" = 1'-0"

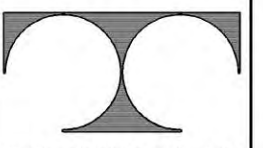

TDI ASSOCIATES, INC.
ARCHITECTS, ENGINEERS, PLANNERS

N8 W22350 JOHNSON DRIVE, SUITE B4
WAUKESHA, WISCONSIN 53186
PHONE 262-437-0400 FAX 262-437-0401

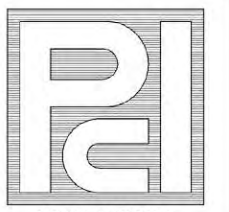

PROFESSIONAL
CONSULTANTS, INC.

300 COTTONWOOD AVE # 7
HARTLAND, WISCONSIN 53029
(262) 367-6080

RUSS DARROW NISSAN
METRO AUTO PARK
WEST METRO BOULEVARD
MILWAUKEE, WISCONSIN

TDI ASSOCIATES, INC
All Rights Reserved

OWNERSHIP OF DOCUMENTS

This document, and the ideas and design incorporated herein, as an instrument of professional service, is the sole property of TDI Associates, Inc., and is not to be used in whole or in part for any other project or purpose without the expressed written authorization of TDI Associates, Inc.

Sheet Title
ELEVATIONS

Issued For: _____ Date: _____

Date: 10-10-2011

Job NO.: 11172.000

Drawn By: RJH

Sheet No.

A2.1

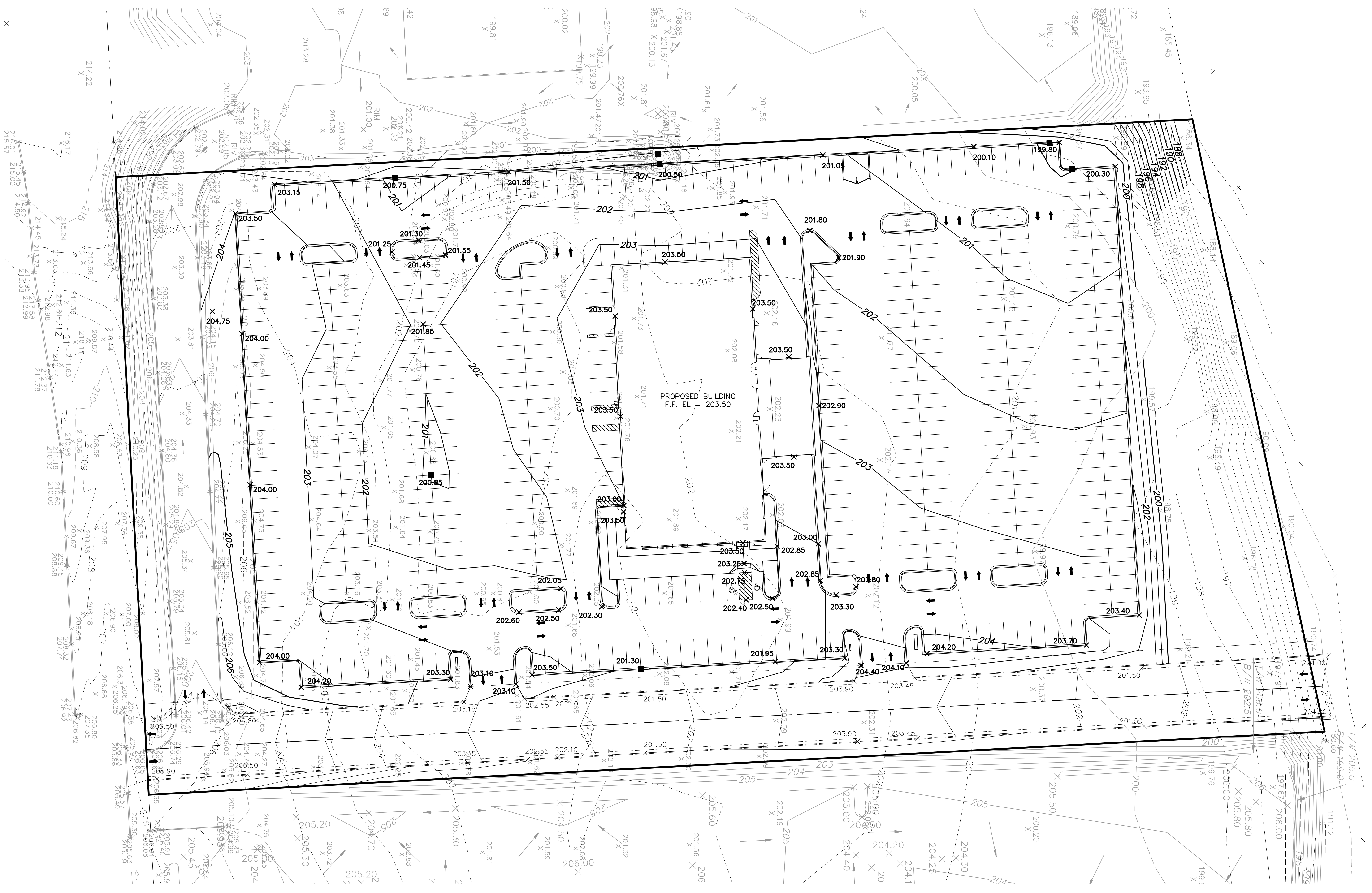

DATE	DESCRIPTION

R.A. Smith National
*Beyond Surveying
 and Engineering*

16745 W. Bluemound Road, Brookfield, WI 53005-5938
 262-781-0000 Fax: 262-781-8466, www.rasmithnational.com

RUSS DARROW NISSAN
 MILWAUKEE, WI
**PRELIMINARY
 GRADING PLAN**

© COPYRIGHT 2008
 R.A. Smith National, Inc.
 DATE: 09-23-11
 SCALE: 1" = 30"
 JOB NO. 3020273.04
 PROJECT MANAGER:
 RYAN J. LANCOUR, P.E.
 DESIGNED BY: JAH
 CHECKED BY: RJL

SHEET NUMBER
CE-2

P:\2020273.04\DWG\3020273.04.dwg 11/02/2011 10:01:20 AM

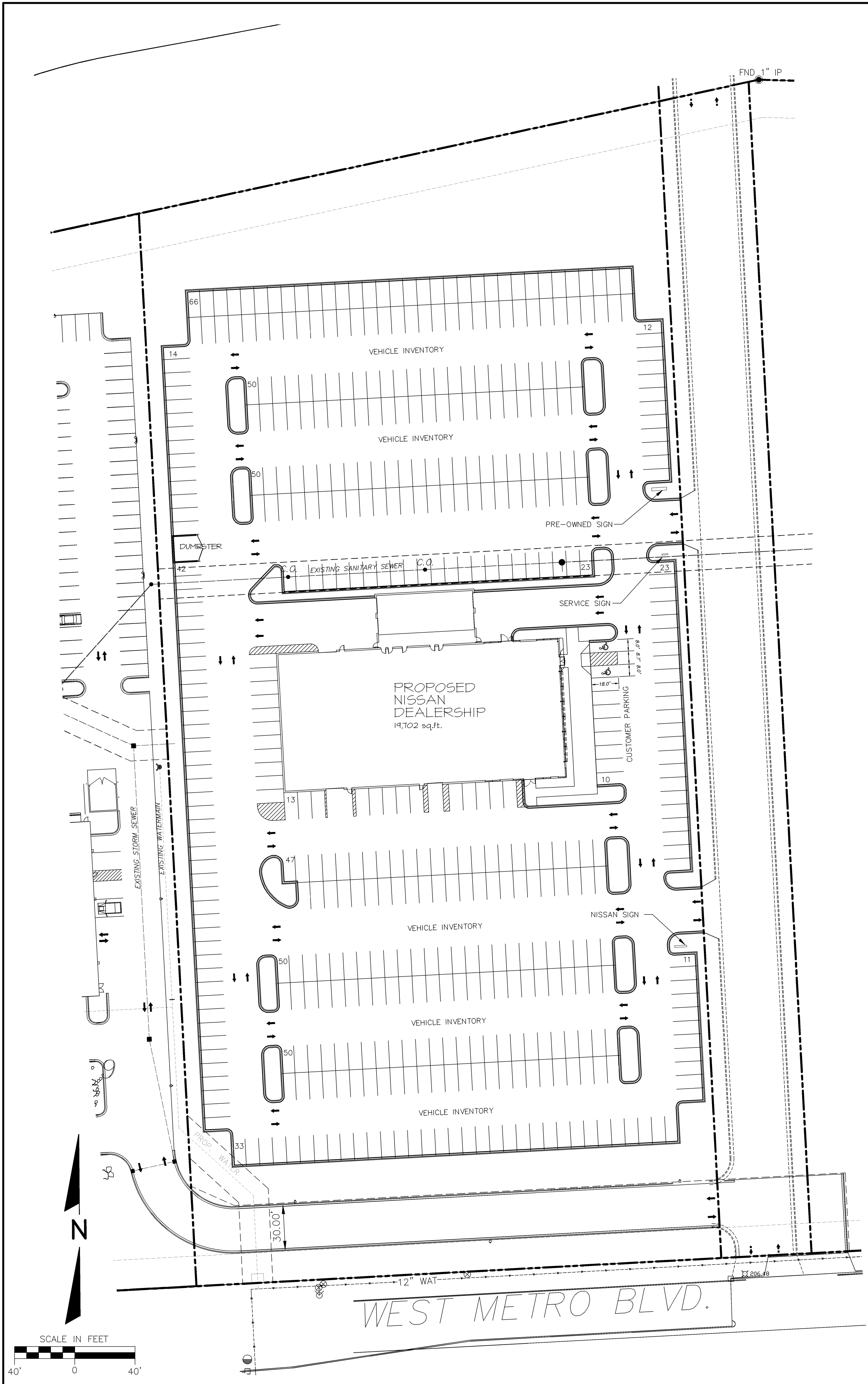

PARKING SPACE TABULATION	
CUSTOMER PARKING=	10 SPACES
INVENTORY / SERVICE PARKING =	484 S.F.
TOTAL PARKING =	494 S.F.

SIGN COPY AREA TABULATION	
SERVICE SIGN COPY AREA=	7 S.F.
PRE-OWNED SIGN COPY AREA =	80 S.F.
NISSAN SIGN COPY AREA =	23 S.F.
TOTAL COPY AREA =	110 S.F.

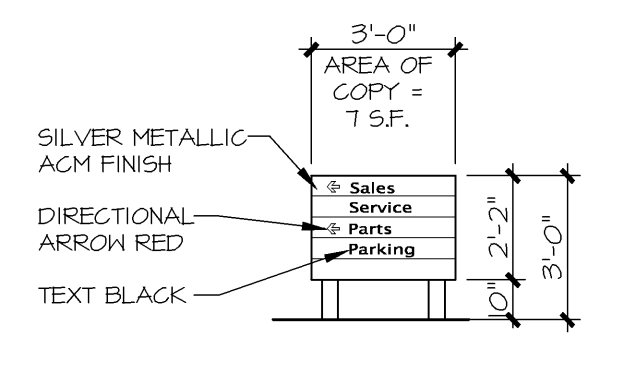

1 SERVICE MONUMENT SIGN
1/4" = 1'-0"

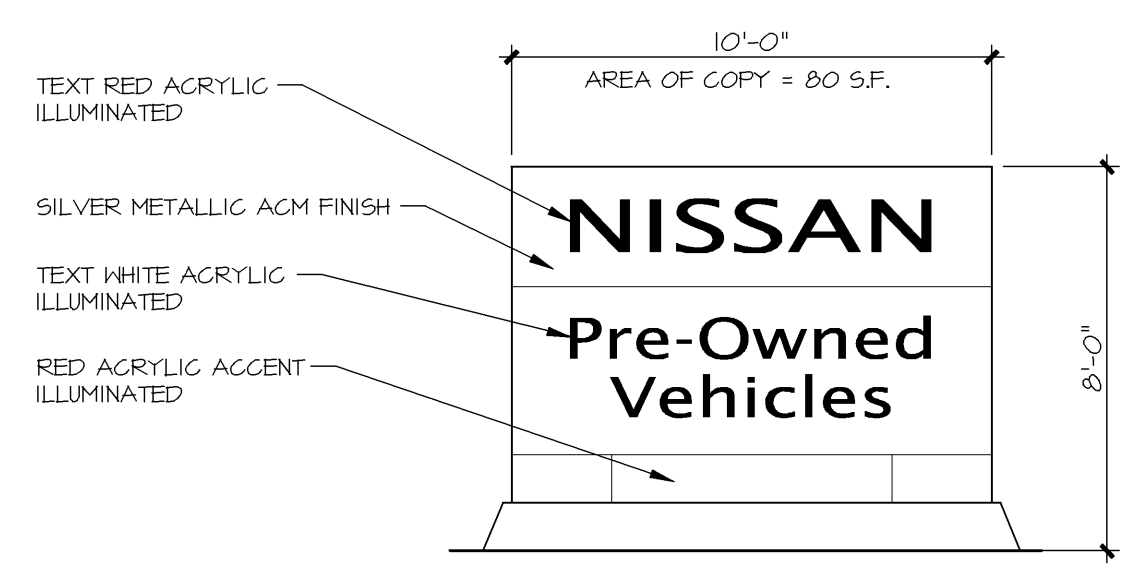

2 PRE-OWNED SIGN
1/4" = 1'-0"

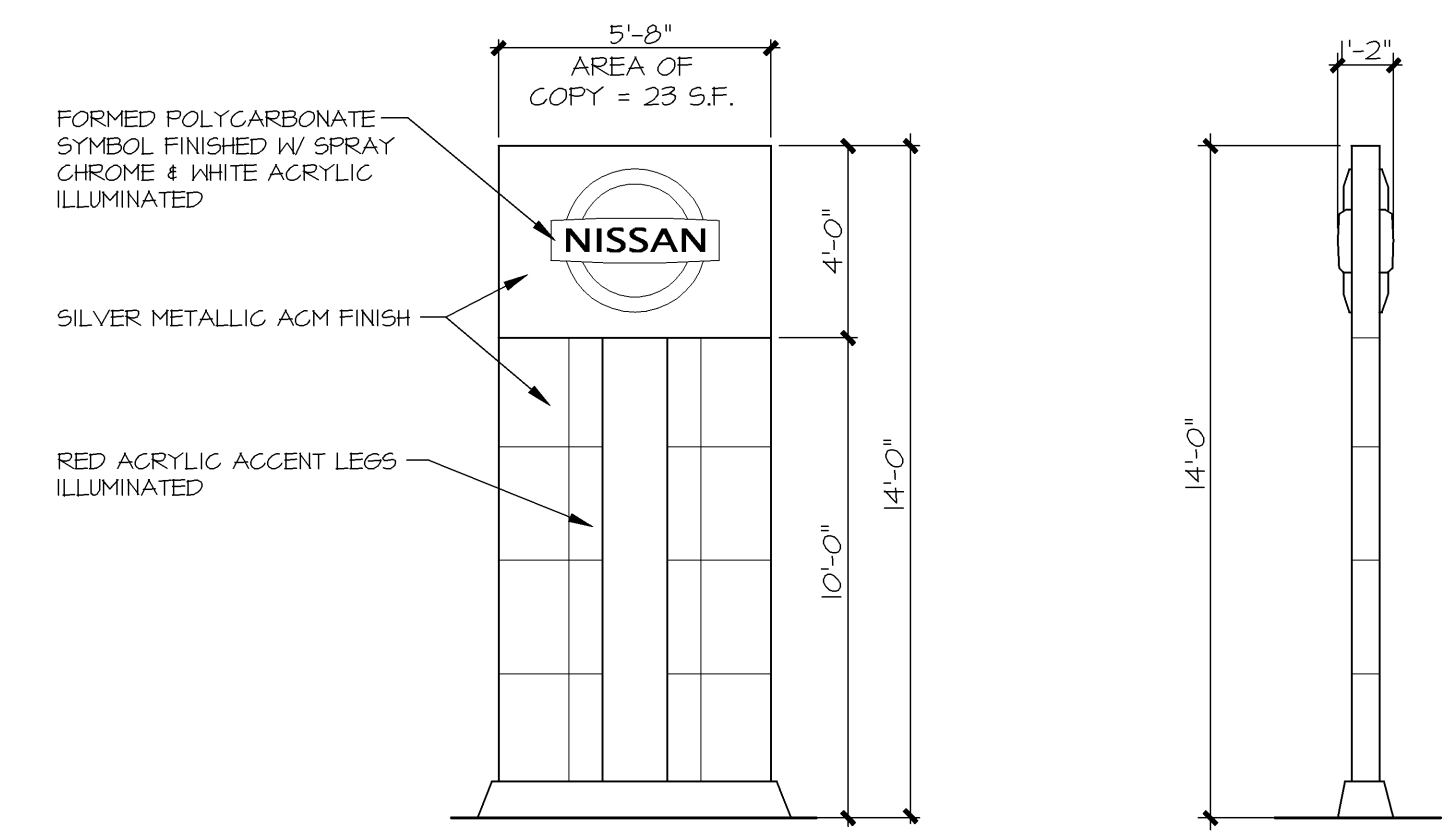

3 NISSAN SIGN
1/4" = 1'-0"

REVISIONS:		TDI ASSOCIATES, INC.		OWNERSHIP OF DOCUMENTS	
NOTE	DATE	All Rights Reserved		This document, and the ideas and design incorporated herein, are the sole property of TDI Associates, Inc. and are not to be used in whole or in part for any other project or purpose without the expressed written authorization of TDI Associates, Inc.	
		NW 22250 JOHNSON DRIVE, SUITE B4 WALWISHA, WISCONSIN 53186 PHONE 262-437-0400 FAX 262-437-0401		 TDI ASSOCIATES, INC. ARCHITECTS, ENGINEERS, PLANNERS	
		CITY OF MILWAUKEE, WI DARROW NISSAN			
SITE DEVELOPMENT PLAN					
SCALE: 1"= 40'-0"		JOB NO: 11-172.000		DATE: 10-20-11	
DESIGNED BY: ROB		DRAWN BY: ROB		CHECKED BY:	
APPROVED BY:		ENGINEER		DATE	
				SHEET SD-1.0	

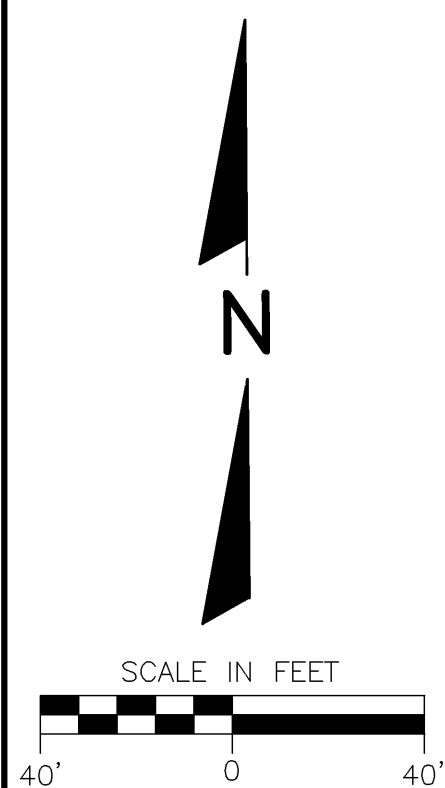
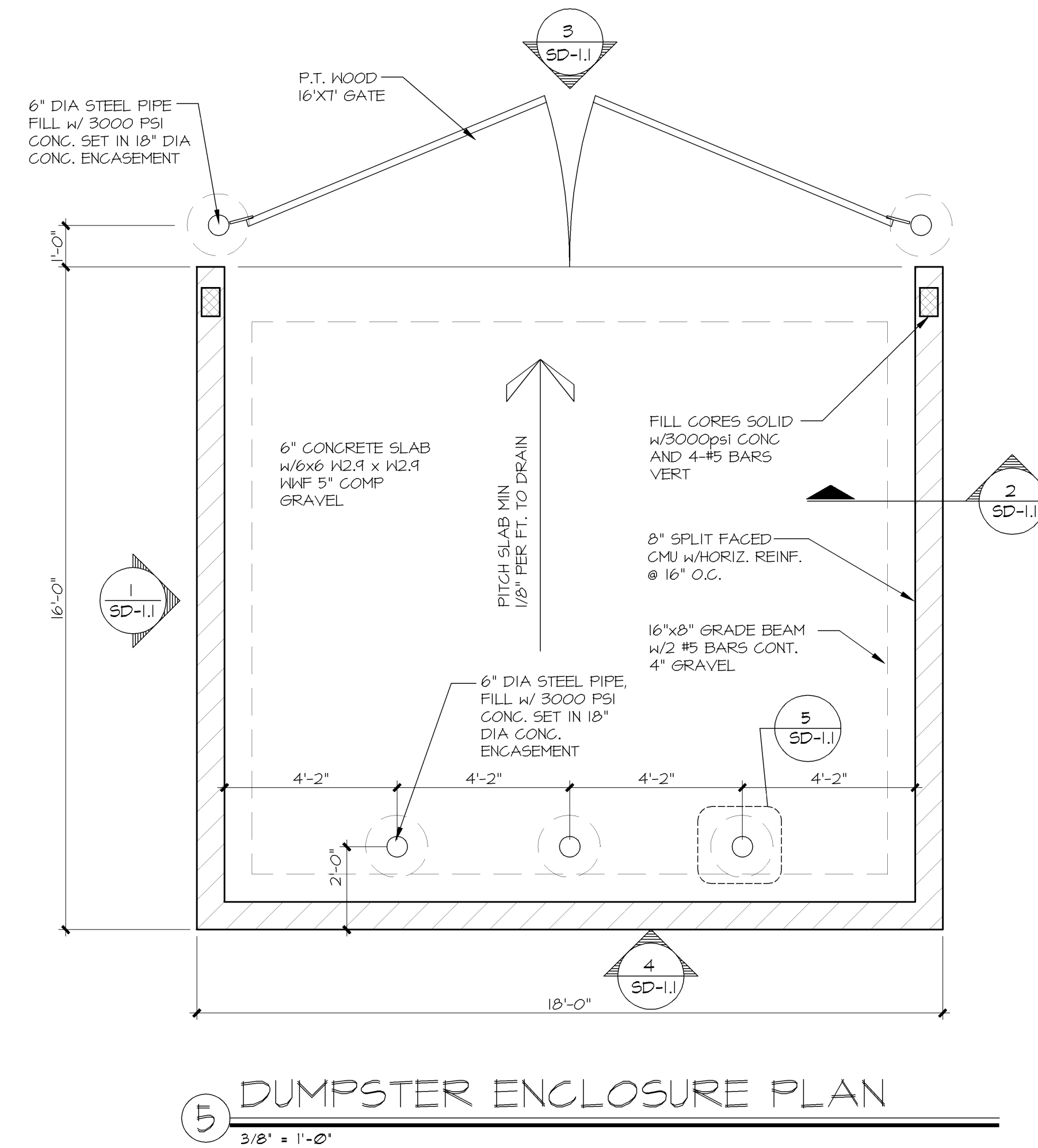
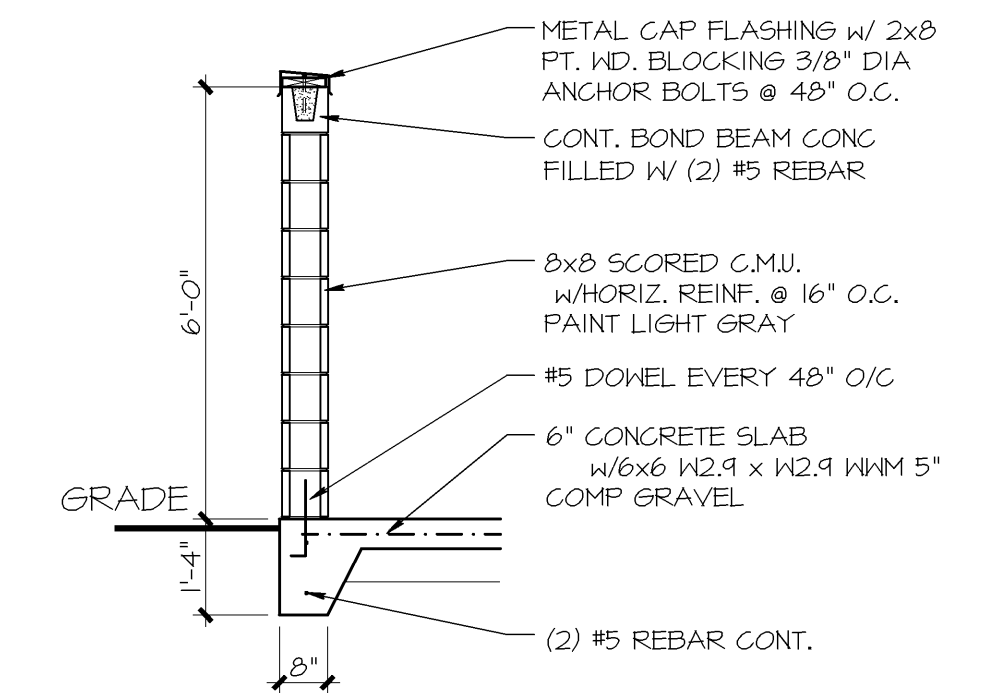
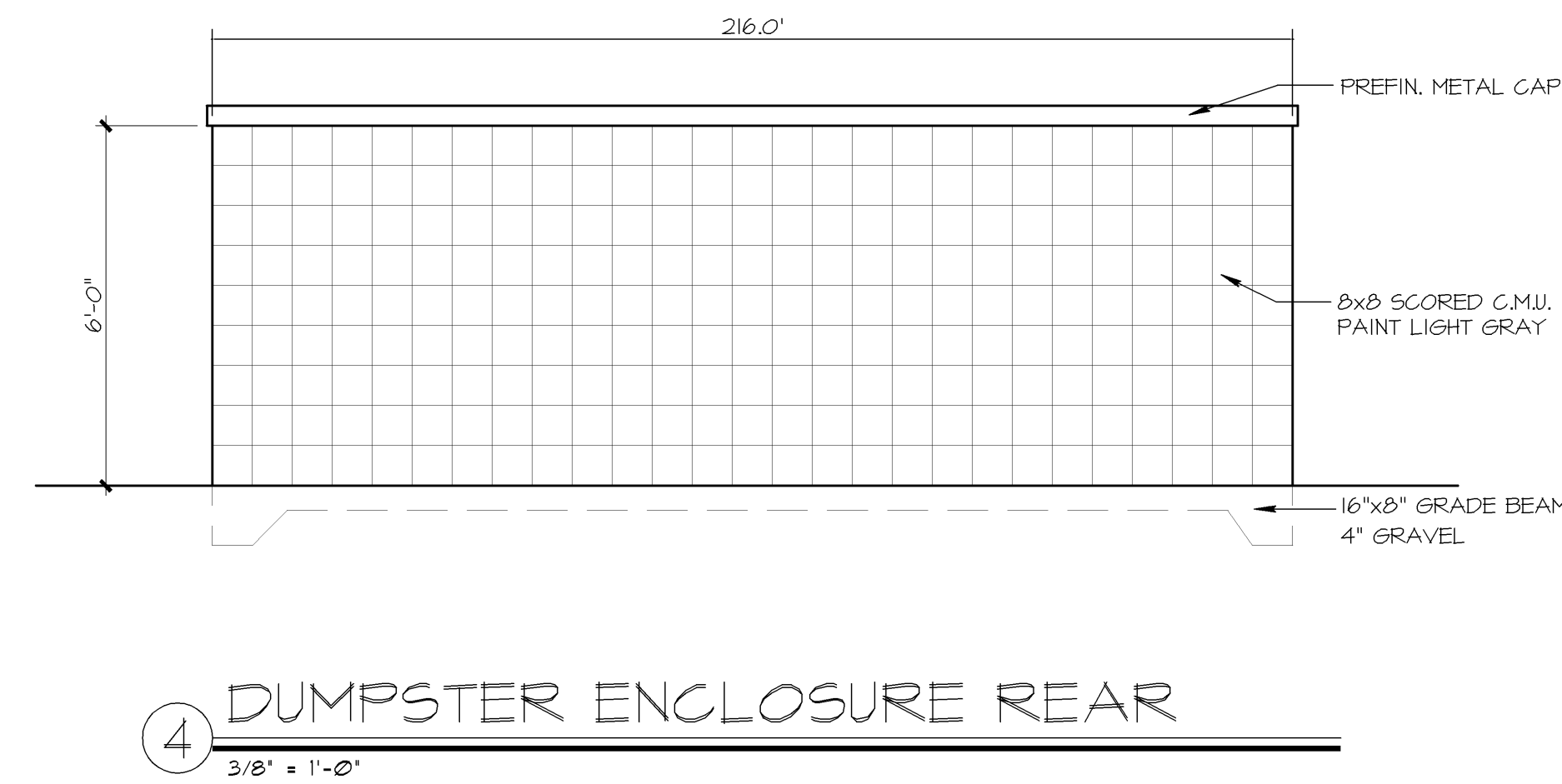
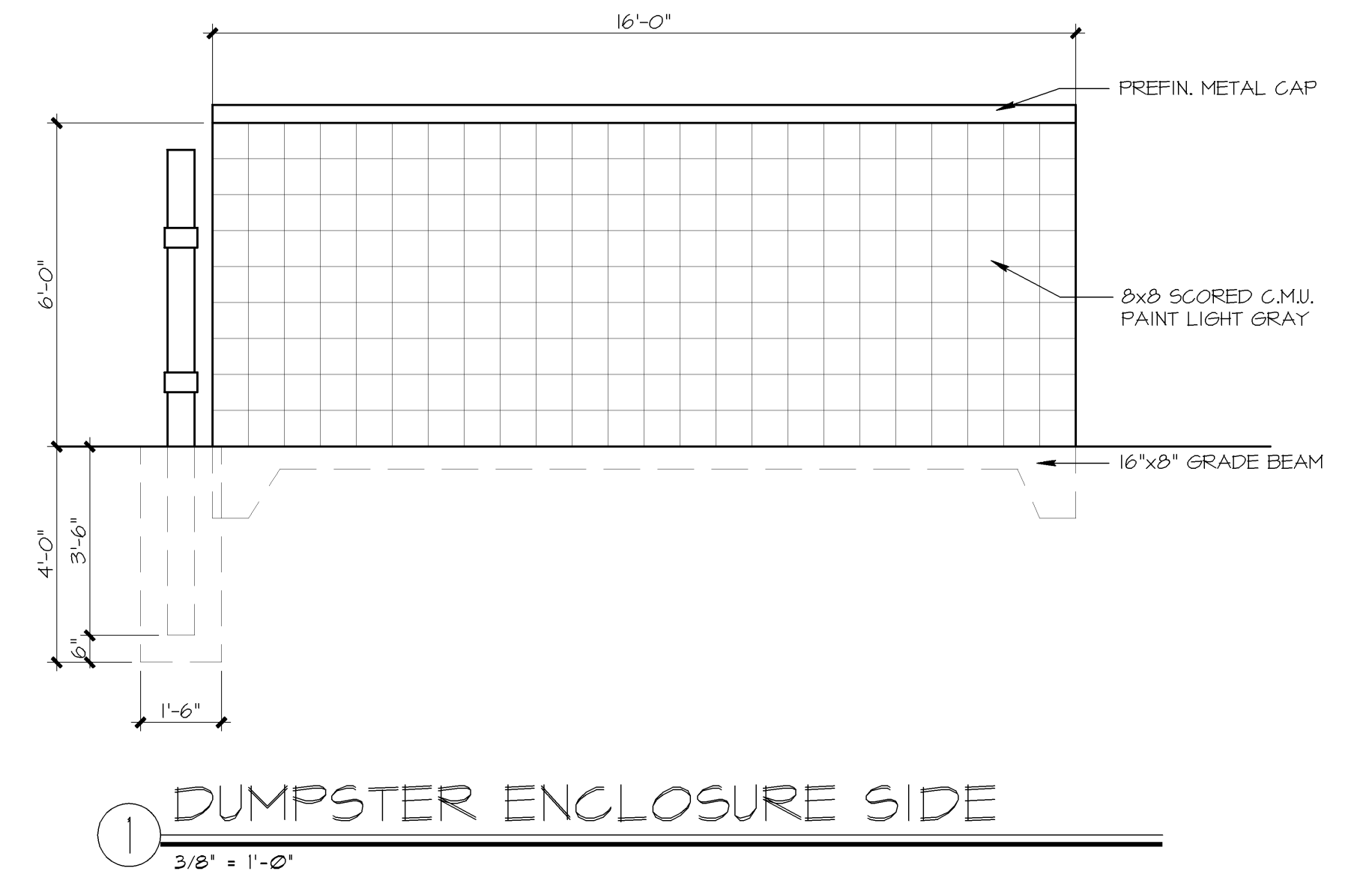
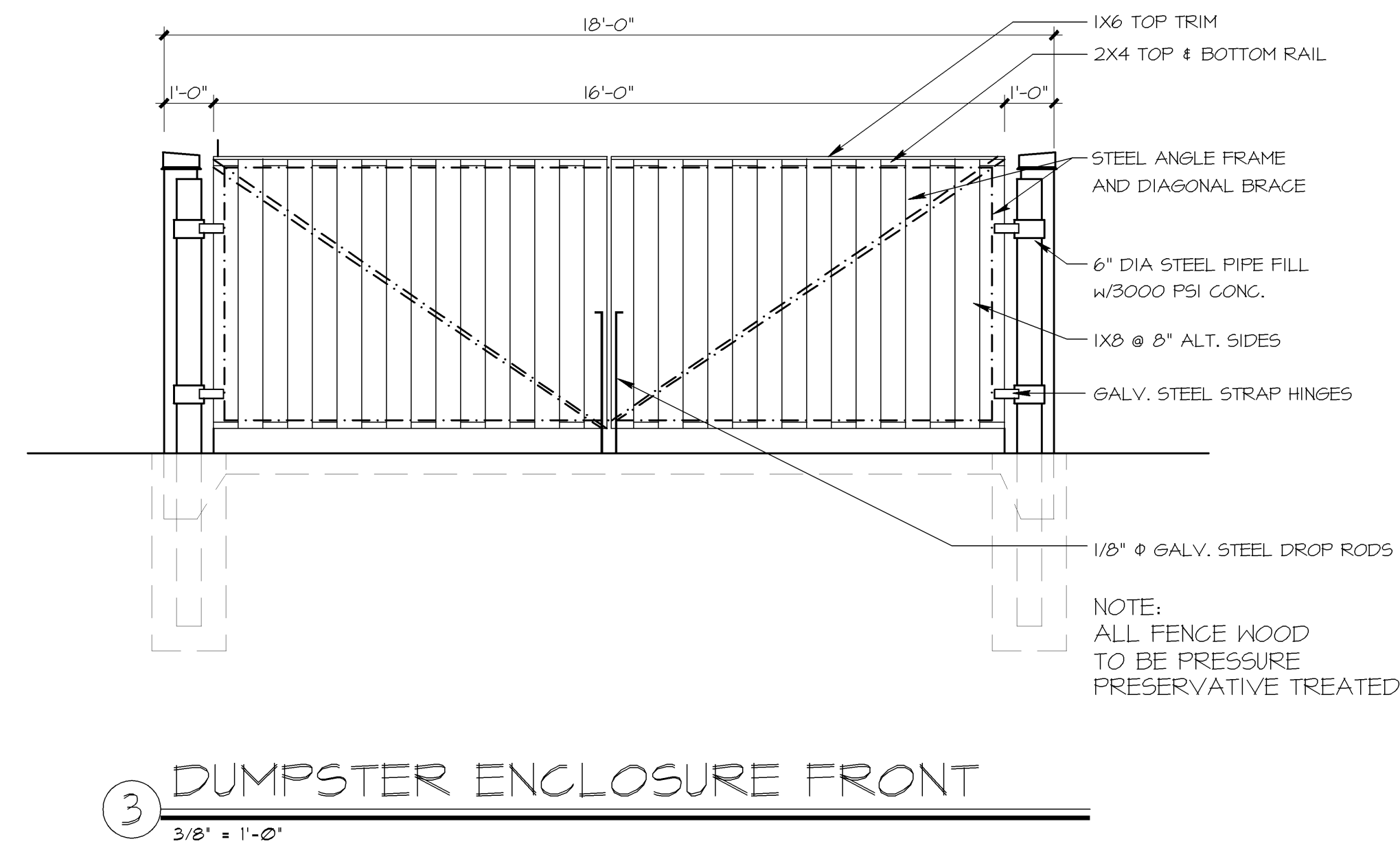
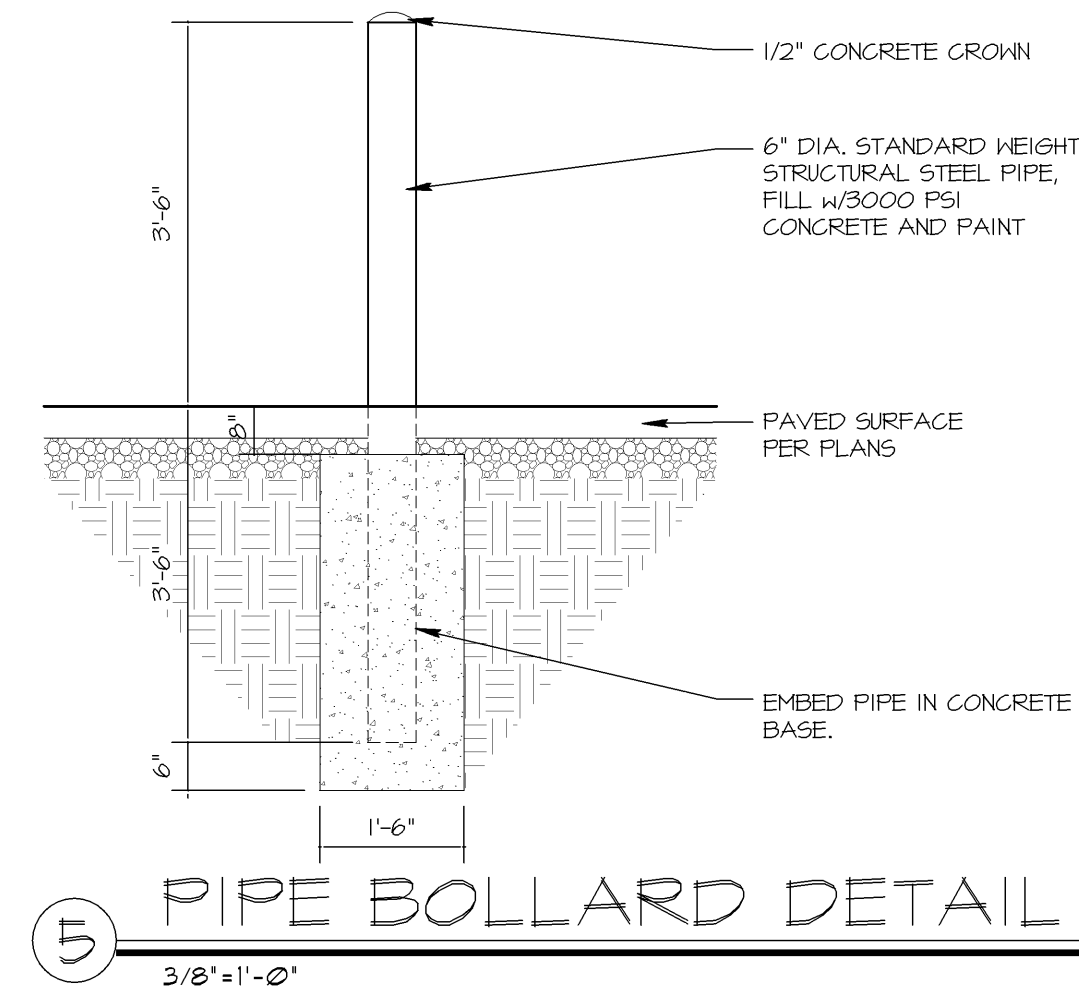

REVISIONS:		T&D ASSOCIATES, INC. All Rights Reserved N8 W2250 JOHNSON DRIVE, SUITE B4 WALWISHA, WISCONSIN 53186 PHONE 262-437-0400 FAX 262-437-0401	 T&D ASSOCIATES, INC. ARCHITECTS, ENGINEERS, PLANNERS	OWNERSHIP OF DOCUMENTS This document, and the ideas and design incorporated herein, are the instruments of professional service, the sole property of T&D Associates, Inc., and are not to be used in whole or in part for any other project or purpose without the expressed written authorization of T&D Associates, Inc.
NOTE	DATE			
		CITY OF MILWAUKEE, WI DARROW NISSAN		
		SITE DEVELOPMENT DETAILS		
		SCALE: 1" = 40'-0"	JOB NO: 11-172.000	DATE: 09-22-11
		DESIGNED BY: ROB	DRAWN BY: ROB	CHECKED BY:
		APPROVED BY:		
		ENGINEER	DATE	SHEET SD-1.1

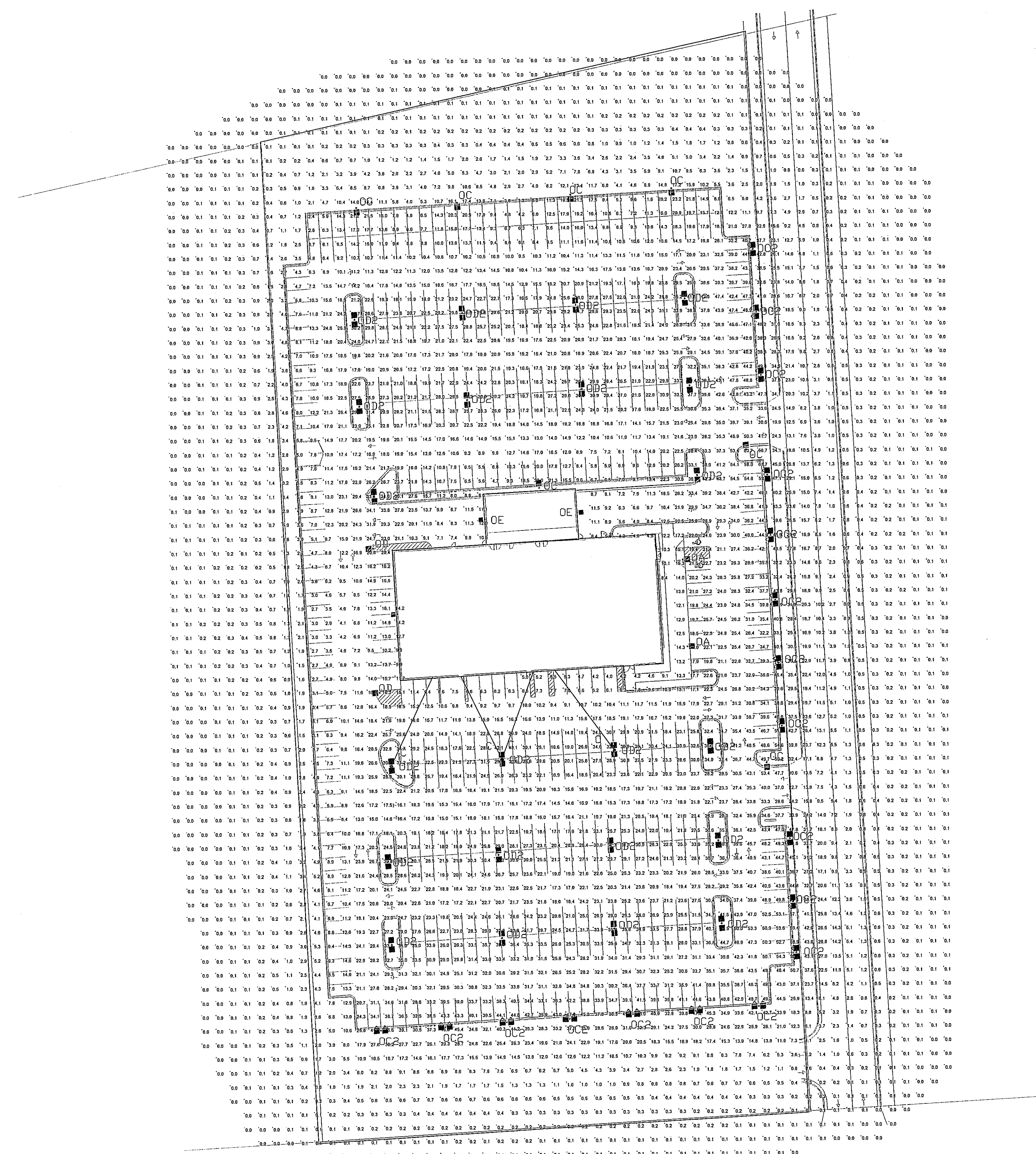

STATISTICS					
Description	Symbol	Avg	Max	Min	Max/Min
Calc Zone #1	+	11.9 ft	63.7 ft	0.0 ft	N/A
FRONT ROW	+	43.8 ft	63.7 ft	27.2 ft	2.3:1
LOT ONLY	+	22.8 ft	63.7 ft	2.4 ft	26.5:1

LUMINAIRE SCHEDULE					
Symbol	Label	Qty	Catalog Number	Description	File
OC	2	EA23-1-0H-1000MH	ECOLIME	CLEAR HORIZONTAL 1000M RATED FOR 10000 LUMENS	EA23-1H-1000MH
OC	7	EA23-1-FH-1000MH	ECOLIME	CLEAR HORIZONTAL 1000M RATED FOR 10000 LUMENS	EA23-FH-1000MH
OC	18	EA23-2-FH-1000MH	ECOLIME	CLEAR HORIZONTAL 1000M RATED FOR 10000 LUMENS	EA23-FH-1000MH
OD	2	EA23-1-0H-1000MH	ECOLIME	CLEAR HORIZONTAL 1000M RATED FOR 10000 LUMENS	EA23-1H-1000MH
OD	22	EA23-2-0H-1000MH	ECOLIME	CLEAR HORIZONTAL 1000M RATED FOR 10000 LUMENS	EA23-2H-1000MH
OE	3	EA18-FH-400PMH	ECOLIME	CLEAR HORIZONTAL 400PM RATED FOR 4000 LUMENS	EA18-FH-400PMH
A	4	FSL100M-MFP	DAYBRITE LARGE FLOODLIGHT	1000MH	FSL100M-MFP

LUMINAIRE LOCATIONS										
No.	Label	X	Y	Z	Mt	Orientation	TR	X	Y	Z
1	OC2	320.0	629.0	26.3	26.3	177.0	0.0			
2	OC2	320.0	425.0	26.3	26.3	177.0	0.0			
3	OC2	322.0	376.0	26.3	26.3	177.0	0.0			
4	OC2	325.0	324.0	26.3	26.3	177.0	0.0			
5	OC2	327.0	280.0	26.3	26.3	177.0	0.0			
6	OC2	332.0	209.0	26.3	26.3	177.0	0.0			
7	OC2	336.0	128.0	26.3	26.3	177.0	0.0			
8	OC	251.0	673.0	26.3	26.3	176.0	0.0	251.1	671.4	0.0
9	OC	179.0	699.0	26.3	26.3	176.0	0.0	179.1	697.4	0.0
10	OC	66.0	664.0	26.3	26.3	176.0	0.0	66.1	662.4	0.0
11	OC	26.0	601.0	26.3	26.3	176.0	0.0	26.1	599.4	0.0
12	OC2	24.0	591.0	26.3	26.3	-4.0	0.0			
13	OC2	29.0	524.0	26.3	26.3	-4.0	0.0			
14	OC2	27.0	519.0	26.3	26.3	-4.0	0.0			
15	OC2	25.0	532.0	26.3	26.3	-4.0	0.0			
16	OC2	27.0	455.0	26.3	26.3	-4.0	0.0			
17	OC2	155.0	490.0	26.3	26.3	-4.0	0.0	154.9	491.6	0.0
18	OC2	268.0	498.0	26.3	26.3	-4.0	0.0			
19	OC2	48.0	383.0	26.3	26.3	-4.0	0.0			
20	OC2	276.0	276.0	26.3	26.3	-4.0	0.0			
21	OC2	45.0	195.0	26.3	26.3	-4.0	0.0			
22	OC2	281.0	208.0	26.3	26.3	-4.0	0.0			
23	OC2	47.0	136.0	26.3	26.3	-4.0	0.0			
24	OC2	283.0	149.0	26.3	26.3	-4.0	0.0			
25	OA	290.0	345.0	26.3	26.3	86.0	0.0	291.6	346.1	0.0
26	OA	257.0	408.0	26.3	26.3	86.0	0.0	258.6	409.1	0.0
27	OE	162.0	442.0	20.0	20.0	86.0	0.0	163.4	442.1	0.0
28	OE	116.0	458.0	20.0	20.0	266.0	0.0	114.6	457.9	0.0
29	OD	36.0	416.0	26.3	26.3	266.0	0.0	34.4	417.9	0.0
30	OD	40.0	315.0	26.3	26.3	266.0	0.0	38.4	316.9	0.0
31	OC	59.0	371.0	20.0	20.0	266.0	0.0	57.4	371.9	0.0
32	OC2	314.0	539.0	26.3	26.3	177.0	0.0			
33	OC2	311.0	584.0	26.3	26.3	177.0	0.0			
34	OC2	334.0	164.0	26.3	26.3	177.0	0.0			
35	OC2	318.0	468.0	26.3	26.3	177.0	0.0			
36	OC	333.0	466.0	20.0	20.0	-4.0	0.0	332.9	467.6	0.0
37	OC	316.0	263.0	20.0	20.0	176.0	0.0	316.1	261.4	0.0
38	OC2	39.0	75.0	26.3	26.3	267.0	0.0			
39	OC2	65.0	77.0	26.3	26.3	267.0	0.0			
40	OC2	129.0	60.0	26.3	26.3	267.0	0.0			
41	OC2	174.0	62.0	26.3	26.3	267.0	0.0			
42	OC2	219.0	65.0	26.3	26.3	267.0	0.0			
43	OC2	264.0	67.0	26.3	26.3	267.0	0.0			
44	OC2	309.0	69.0	26.3	26.3	267.0	0.0			
45	OD2	127.0	267.0	26.3	26.3	-4.0	0.0			
46	OD2	126.0	140.0	26.3	26.3	-4.0	0.0			
47	OD2	124.0	199.0	26.3	26.3	-4.0	0.0			
48	OD2	207.0	273.0	26.3	26.3	-4.0	0.0			
49	OD2	290.0	146.0	26.3	26.3	-4.0	0.0			
50	OD2	204.0	265.0	26.3	26.3	-4.0	0.0			
51	OD2	191.0	265.0	26.3	26.3	-4.0	0.0			
52	OD2	164.0	233.0	26.3	26.3	-4.0	0.0			
53	OD2	162.0	590.0	26.3	26.3	-4.0	0.0			
54	OC2	195.0	530.0	26.3	26.3	-4.0	0.0			
55	A	49.0	263.0	20.0	20.0	25.5	85.1	78.0	326.0	14.0
56	A	127.0	267.0	20.0	20.0	25.2	84.8	68.0	326.0	14.0
57	A	127.0	20.0	20.0	20.0	20.4	84.8	150.0	329.0	14.0
58	A	207.0	273.0	20.0	20.0	25.4	85.2	165.0	330.0	14.0

Plan View
Scale 1"=30'

DARROW NISSAN
MILWAUKEE, WI

Designer
EH
Date
Oct 11 2011
Scale
36X48 PAPER
Drawing No.

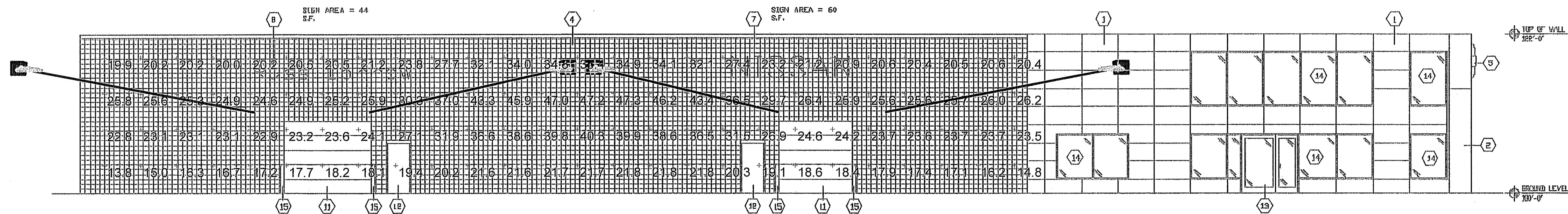

2 SOUTH ELEVATION
1/8" = 1'-0"

South Elevation
Scale 1" = 16'

STATISTICS						
Description	Symbol	Avg	Max	Min	Max/Min	Avg/Min
Calc Zone #1	+	26.1 fc	47.3 fc	13.8 fc	3.4:1	1.9:1

LUMINAIRE SCHEDULE									
Symbol	Label	Qty	Catalog Number	Description	Lamp	File	Lumens	LLF	Watts
■	C	4	FSL10XM-MHP	DAYBRITE LARGE FLOODLIGHT	1000MH	FSL1MMHP.ie s	110000	0.72	1100

LUMINAIRE LOCATIONS										
No.	Label	Location			MH	Orientation	Tilt	Aim		
		X	Y	Z				X	Y	Z
1	C	691.0	-484.0	20.0	20.0	28.1	85.0	723.0	-424.0	14.0
2	C	766.0	-484.0	20.0	20.0	-24.2	84.8	739.0	-424.0	14.0
3	C	842.0	-484.0	20.0	20.0	-28.1	85.0	810.0	-424.0	14.0
4	C	770.0	-484.0	20.0	20.0	22.6	84.7	795.0	-424.0	14.0

DARROW NISSAN
BUILDING FLOODLIGHTING

Designer
Date
Oct 10 2011
Scale
11X17 PAPER
Drawing No.

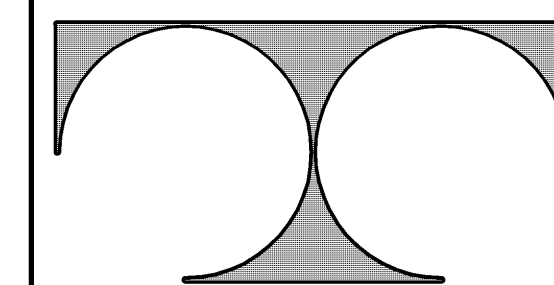

TDI ASSOCIATES, INC.
ARCHITECTS, ENGINEERS, PLANNERS

N8 W22350 JOHNSON DRIVE, SUITE B4
WAUKESHA, WISCONSIN 53186
PHONE 262-437-0400 FAX 262-437-0401

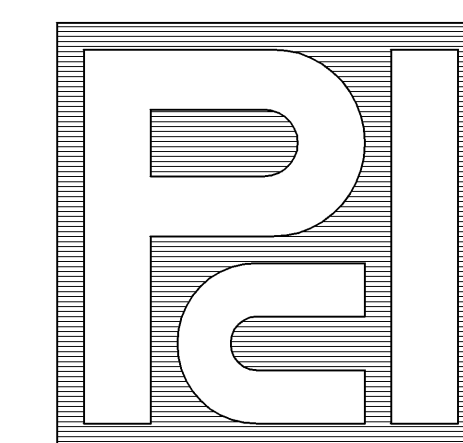

PROFESSIONAL
CONSULTANTS, INC.

300 COTTONWOOD AVE # 7
HARTLAND, WISCONSIN 53029
(262) 367-6080

RUSS DARROW NISSAN
METRO AUTO PARK

WEST METRO BOULEVARD
MILWAUKEE, WISCONSIN

TDI ASSOCIATES, INC
All Rights Reserved

OWNERSHIP OF DOCUMENTS

This document, and the ideas and design incorporated herein, as an instrument of professional service, is the sole property of TDI Associates, Inc., and is not to be used in whole or in part for any other project or purpose without the expressed written authorization of TDI Associates, Inc.

Sheet Title
FLOOR PLAN

Issued For: Date:

Date: 09-22-2011

Job NO.: 11172.000

Drawn By: RJH

Sheet No.

A1.1

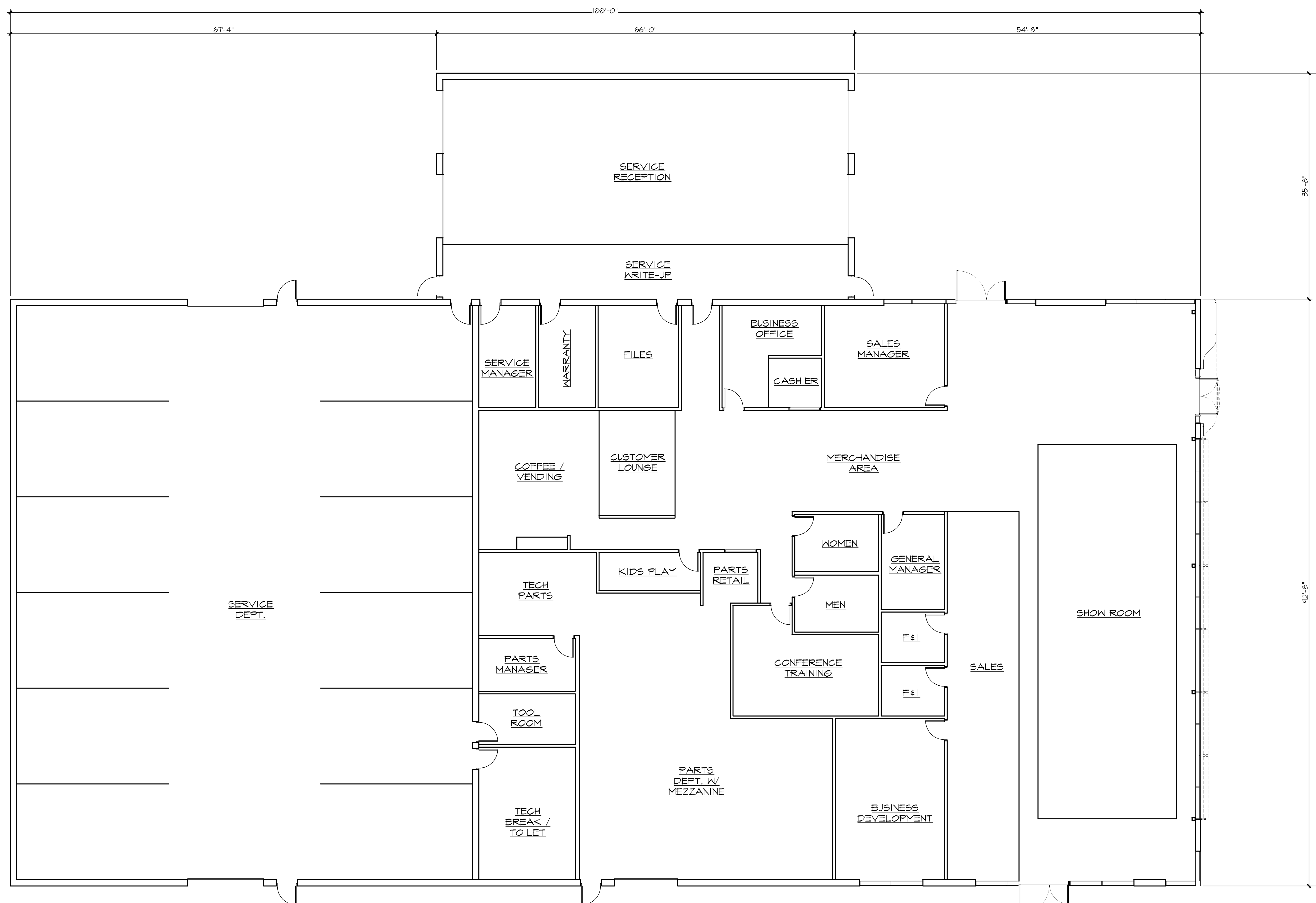

1 FLOOR PLAN
1/8"=1'-0"
NORTH

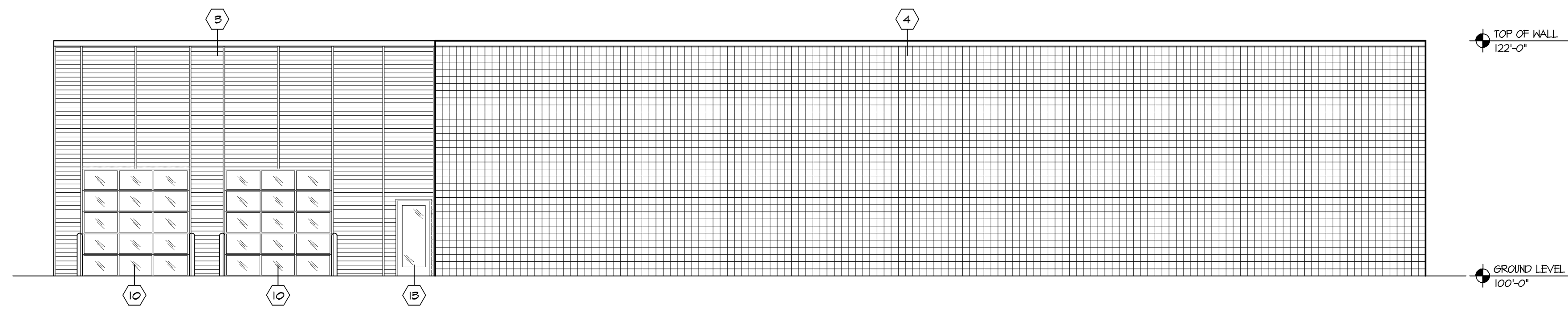

1 WEST ELEVATION
1/8" = 1'-0"

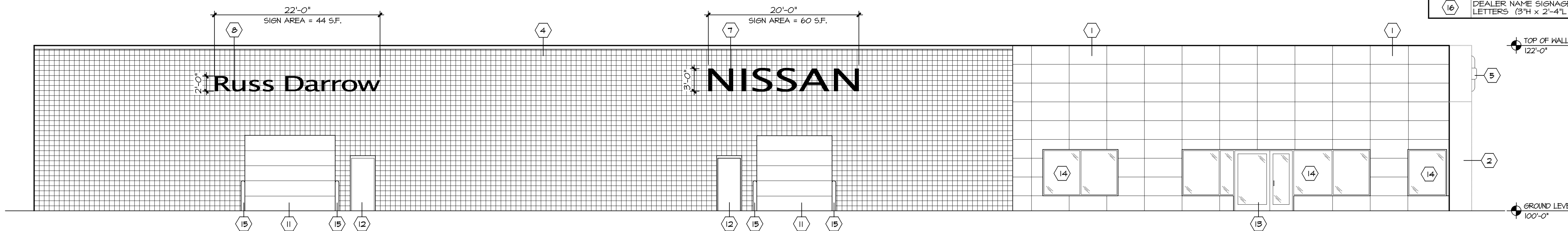

2 SOUTH ELEVATION
1/8" = 1'-0"

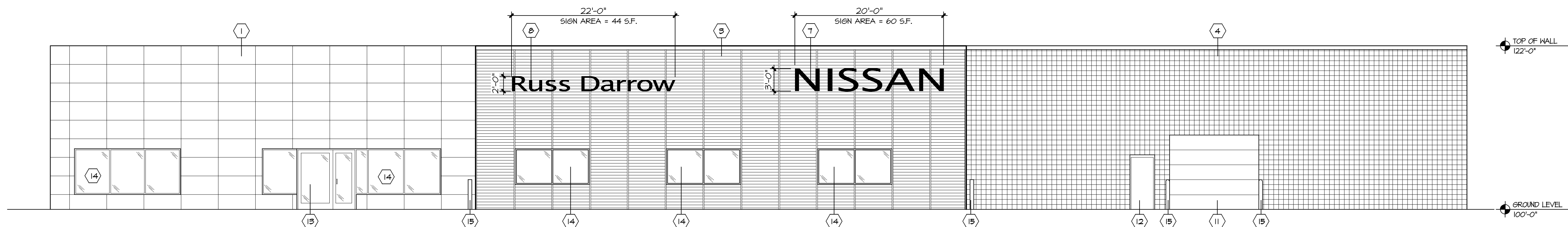

3 NORTH ELEVATION
1/8" = 1'-0"

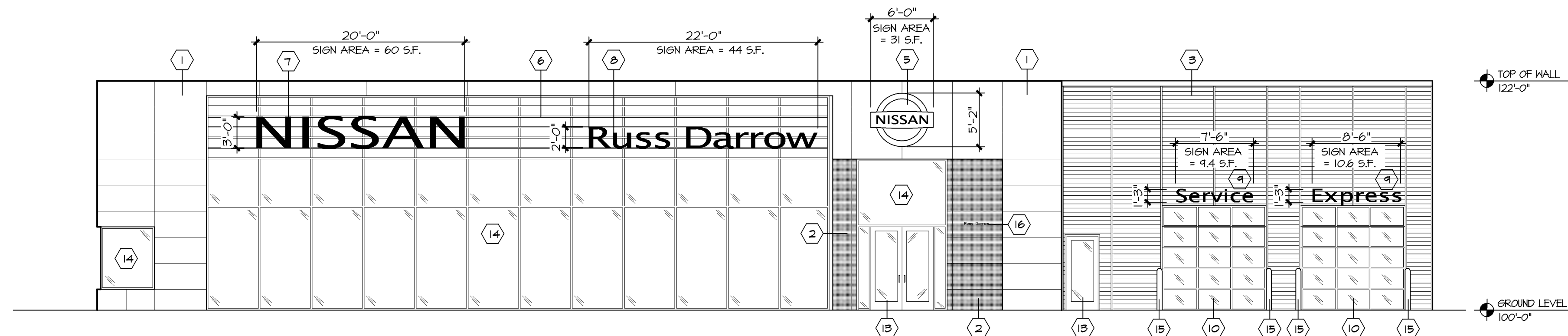

4 EAST ELEVATION
1/8" = 1'-0"

MATERIAL KEY

TAG	DESCRIPTION
1	ACM-1 SILVER ACM METALLIC PANELS
2	ACM-2 RED ACM TO MATCH NISSAN PANELS (ENTRANCE ELEMENT ONLY)
3	ARM-1 SILVER METALLIC RIBBED METAL PANELS
4	8 x 8 SCOURED CMU WALL PAINTED LIGHT GRAY
5	SHOWROOM ENTRY NISSAN BRAND SYMBOL SIGNAGE
6	SILVER METALLIC LOUVER FASCIA
7	NISSAN CHANNEL LETTERS SIGNAGE, RED ACRYLIC FACE, L.E.D. INTERNAL ILLUMINATION (36"H x 20'-0"L approx.)
8	DEALER NAME SIGNAGE, WHITE ACRYLIC FACE, L.E.D. INTERNAL ILLUMINATION (24"H x 22'-0"L approx.)
9	SERVICE CHANNEL LETTERS SIGNAGE, WHITE ACRYLIC FACE, L.E.D. INTERNAL ILLUMINATION (15"H)
10	OVERHEAD DOOR WITH VISION GLAZING IN ALUMINUM FRAMES
11	INSULATED OVERHEAD DOOR PAINTED LIGHT GRAY TO MATCH CMU WALLS
12	INSULATED HOLLOW METAL DOOR
13	PREFINISHED CLEAR ANODIZED ALUMINUM DOOR W/ LITE
14	1" CLEAR INSULATED GLASS W/ CLEAR ANODIZED ALUMINUM MULLIONS THERMALLY BROKEN
15	6" PIPE BOLLARD PAINTED DARK GRAY
16	DEALER NAME SIGNAGE, LETTERS (3"H x 2'-4"L approx.)

WALL SIGNAGE AREA

NISSAN SIGN EAST ELEVATION=	60 S.F.
RUSS DARROW SIGN EAST ELEVATION=	44 S.F.
NISSAN BRAND SYMBOL SIGN EAST ELEVATION=	31 S.F.
SERVICE SIGN EAST ELEVATION=	9.4 S.F.
EXPRESS SIGN EAST ELEVATION=	10.6 S.F.
RUSS DARROW SIGN @ ENTRANCE EAST ELEVATION=	0.5 S.F.
NISSAN SIGN NORTH ELEVATION=	60 S.F.
RUSS DARROW SIGN NORTH ELEVATION=	44 S.F.
NISSAN SIGN SOUTH ELEVATION=	60 S.F.
RUSS DARROW SIGN SOUTH ELEVATION=	44 S.F.
TOTAL SIGN AREA =	363.5 S.F.

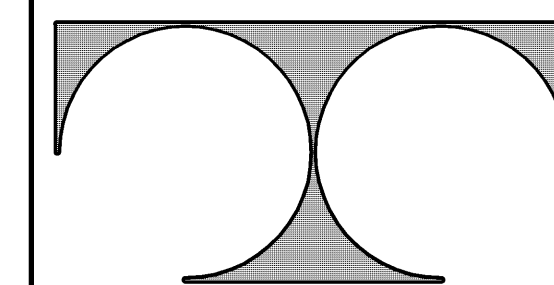

TDI ASSOCIATES, INC.
ARCHITECTS, ENGINEERS, PLANNERS

N8 W22350 JOHNSON DRIVE, SUITE B4
WAUKESHA, WISCONSIN 53186
PHONE 262-437-0400 FAX 262-437-0401

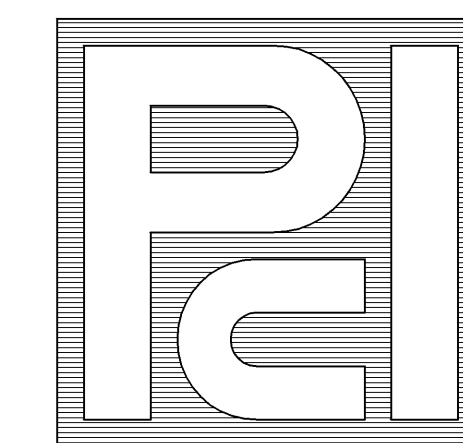

PROFESSIONAL
CONSULTANTS, INC.

300 COTTONWOOD AVE # 7
HARTLAND, WISCONSIN 53029
(262) 367-6080

RUSS DARROW NISSAN
METRO AUTO PARK
WEST METRO BOULEVARD
MILWAUKEE, WISCONSIN

TDI ASSOCIATES, INC
All Rights Reserved

OWNERSHIP OF DOCUMENTS

This document, and the ideas and design incorporated herein, as an instrument of professional service, is the sole property of TDI Associates, Inc., and is not to be used in whole or in part for any other project or purpose without the expressed written authorization of TDI Associates, Inc.

Sheet Title
ELEVATIONS

Issued For: Date:

Date: 10-10-2011

Job NO.: 11172.000

Drawn By: RJH

Sheet No.

A2.1