



Certificate of Appropriateness

LIVING WITH HISTORY

Milwaukee Historic Preservation Commission/200 E. Wells Street/Milwaukee, WI 53202/phone 414-286-5712/fax 414-286-3004

Property 2717 E. BELLEVUE PL., North Point North Historic District
Description of work Demolish existing 2-car frame garage and build a new, 2-car frame garage at southwest corner of lot.
Date issued 9/29/2010

PTS ID 68272 COA, demolish old garage; build new one

In accordance with the provisions of Section 308-81(9) of the Milwaukee Code of Ordinances, the Milwaukee Historic Preservation Commission has issued a certificate of appropriateness for the work listed above. The work was found to be consistent with preservation guidelines. The following conditions apply to this certificate of appropriateness:

All work will be done according to attached drawings. (NOTE: owner supplied with set of scale drawings). New garage will be built on roughly the same site as the old one. All exterior trim, windows, and siding will be made of wood. Overhead doors will be made to look like traditional sliding or swinging doors.

All work must be done in a craftsman-like manner, and must be completed within one year of the date this certificate was issued. Staff must approve any changes or additions to this certificate before work begins. Work that is not completed in accordance with this certificate may be subject to correction orders or citations. If you require technical assistance, please contact Paul Jakubovich of the Historic Preservation staff as follows: Phone: (414) 286-5712 Fax: (414) 286-3004 E-mail: pjakub@milwaukee.gov.

If permits are required, you are responsible for obtaining them from the Milwaukee Development Center. If you have questions about permit requirements, please consult the Development Center's web site, www.mkedcd.org/build, or call (414) 286-8210.

Paul Jakubovich
City of Milwaukee Historic Preservation

Copies to: Development Center, Ald. Nik Kovac, Inspector Jim Friedrichs (286-5982)

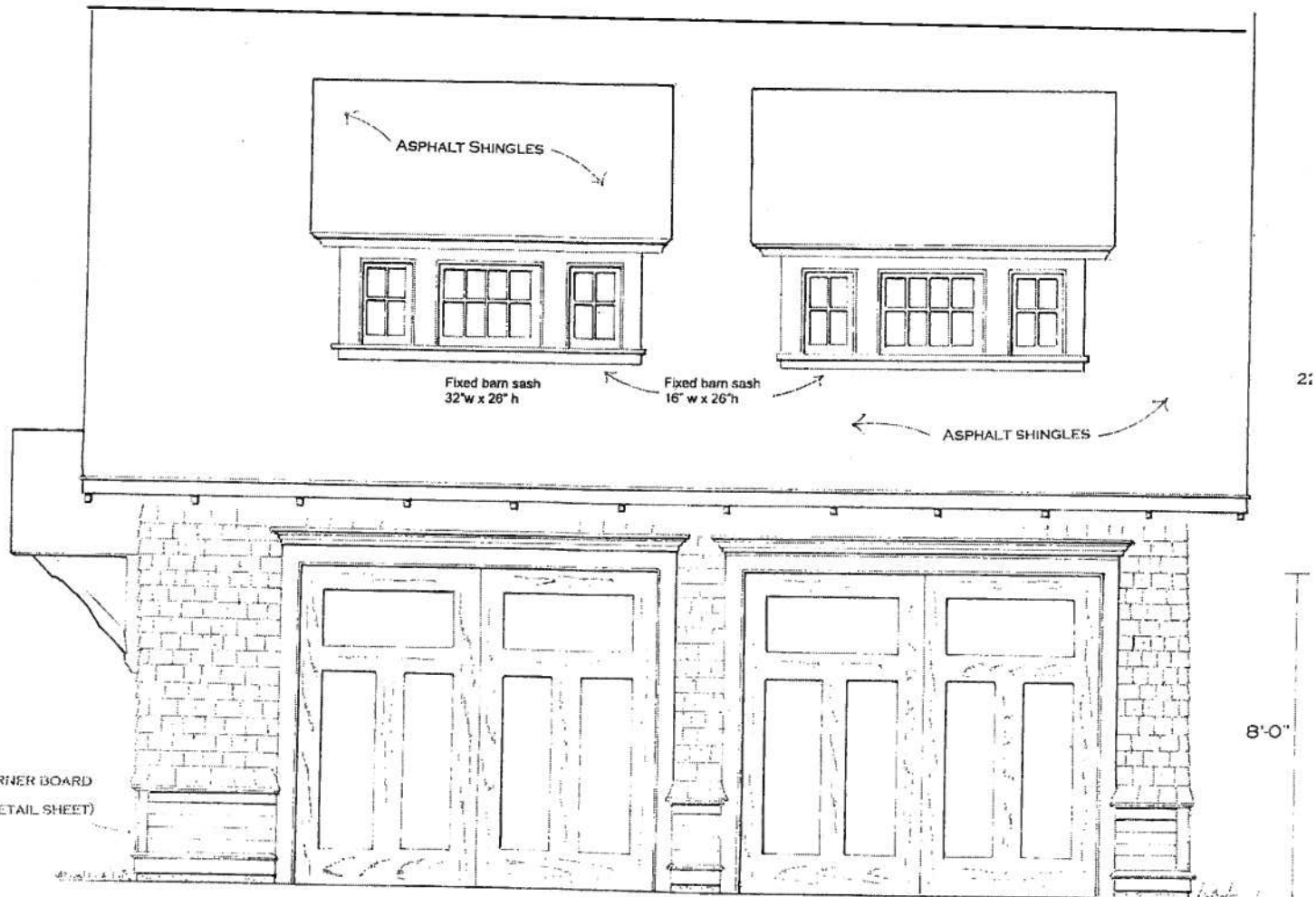

Front elevation

North elevation



East
Elevation

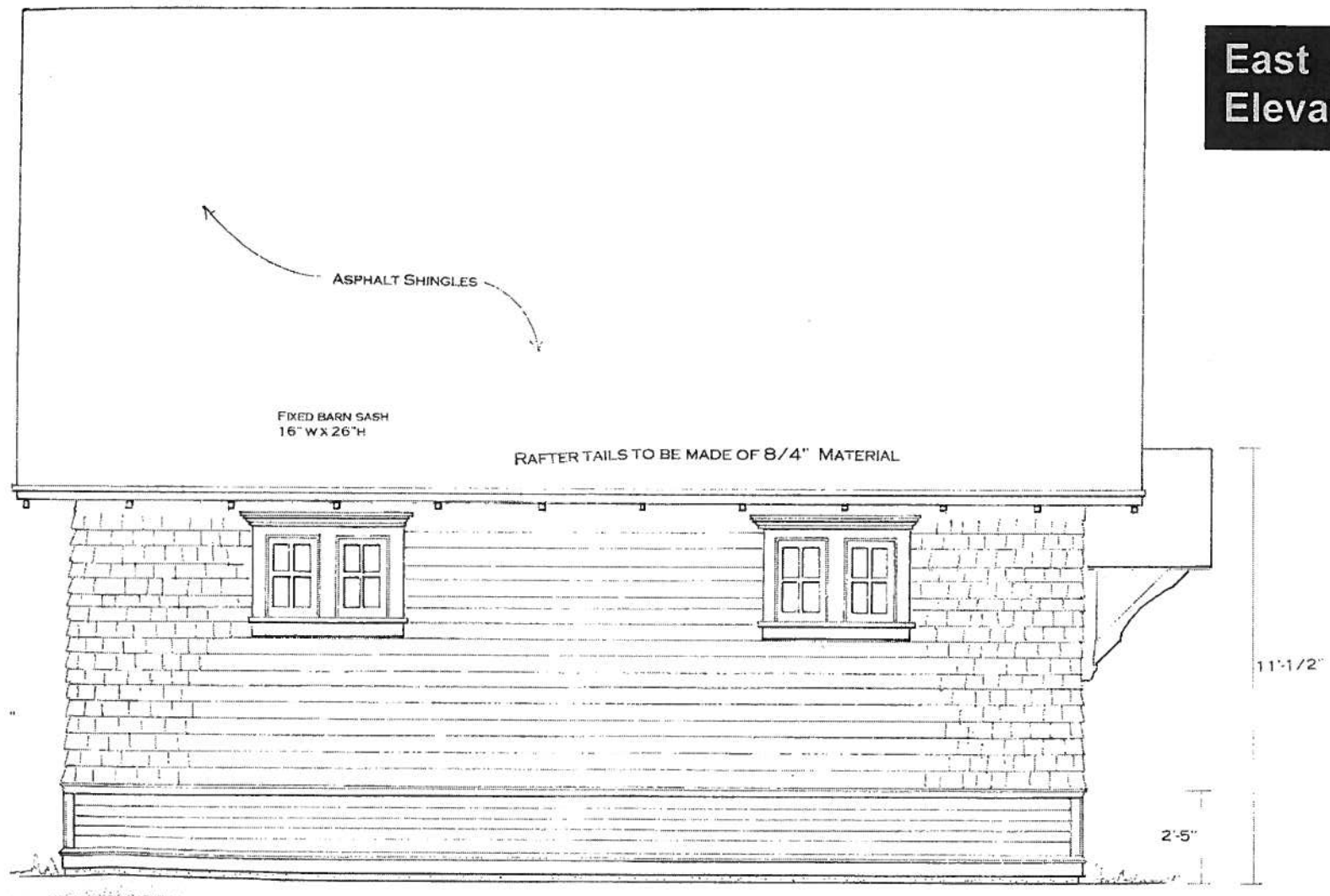

EVERY FOURTH COURSE OF WOOD SHINGLES IN GABLE ENDS TO BE DOUBLED IN THICKNESS WITH AN EXPOSURE OF 2-1/2"

ATTACHED AT THE FACTORY ALONG WITH EXTENDED SILL EARS. WINDOW AND DOOR TOP MOLDINGS CAN BE FIELD INSTALLED.

South Elevation

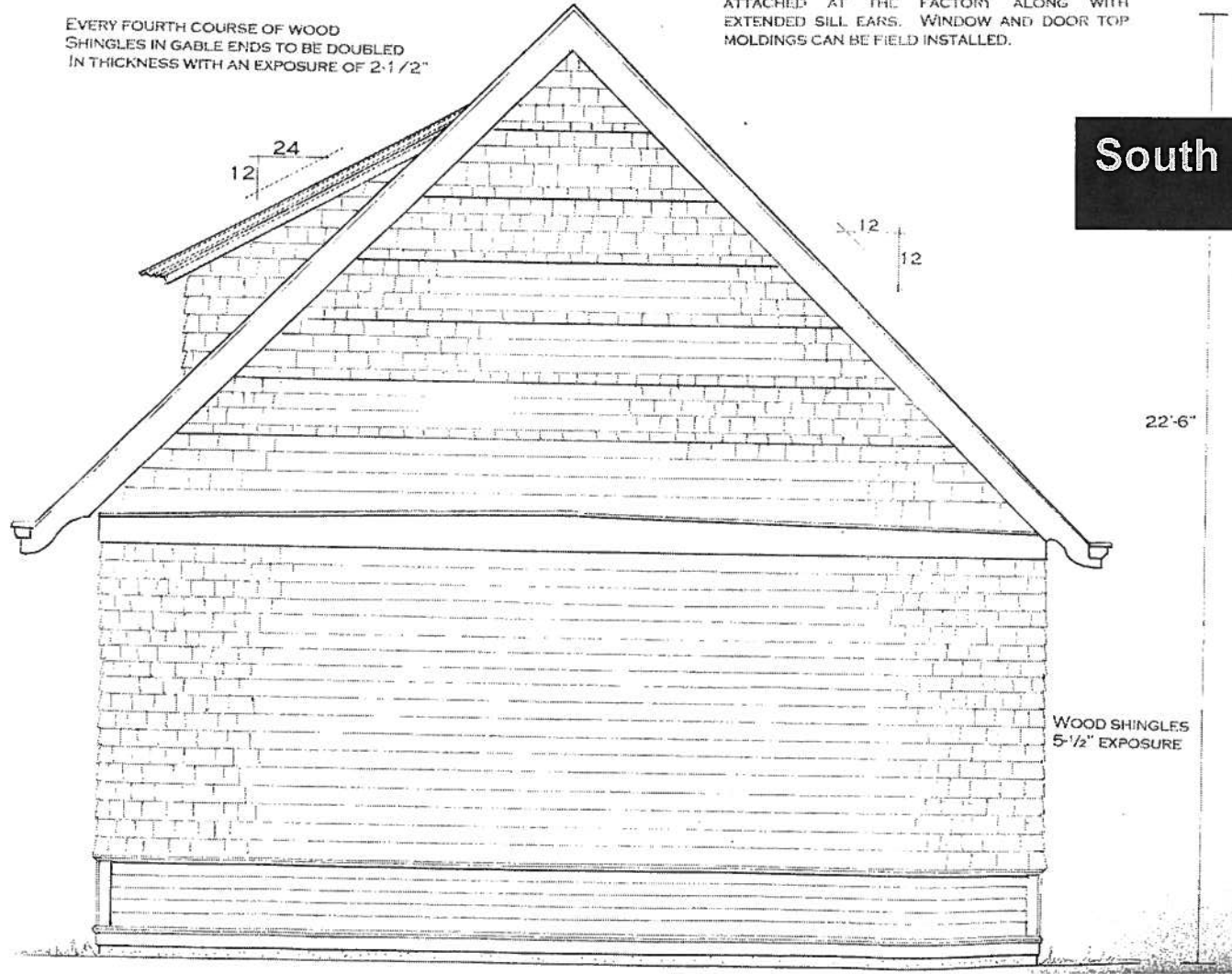

WOOD SHINGLES
5-1/2" EXPOSURE

Plan

1/2"

1/2"

1'-0"

3"

SERVICE DOOR 3'-0" x 7'-0"

2 x 12 HEADERS DOUBLED
OVERALL ALL WINDOW AND
DOOR OPENINGS

22'-0"

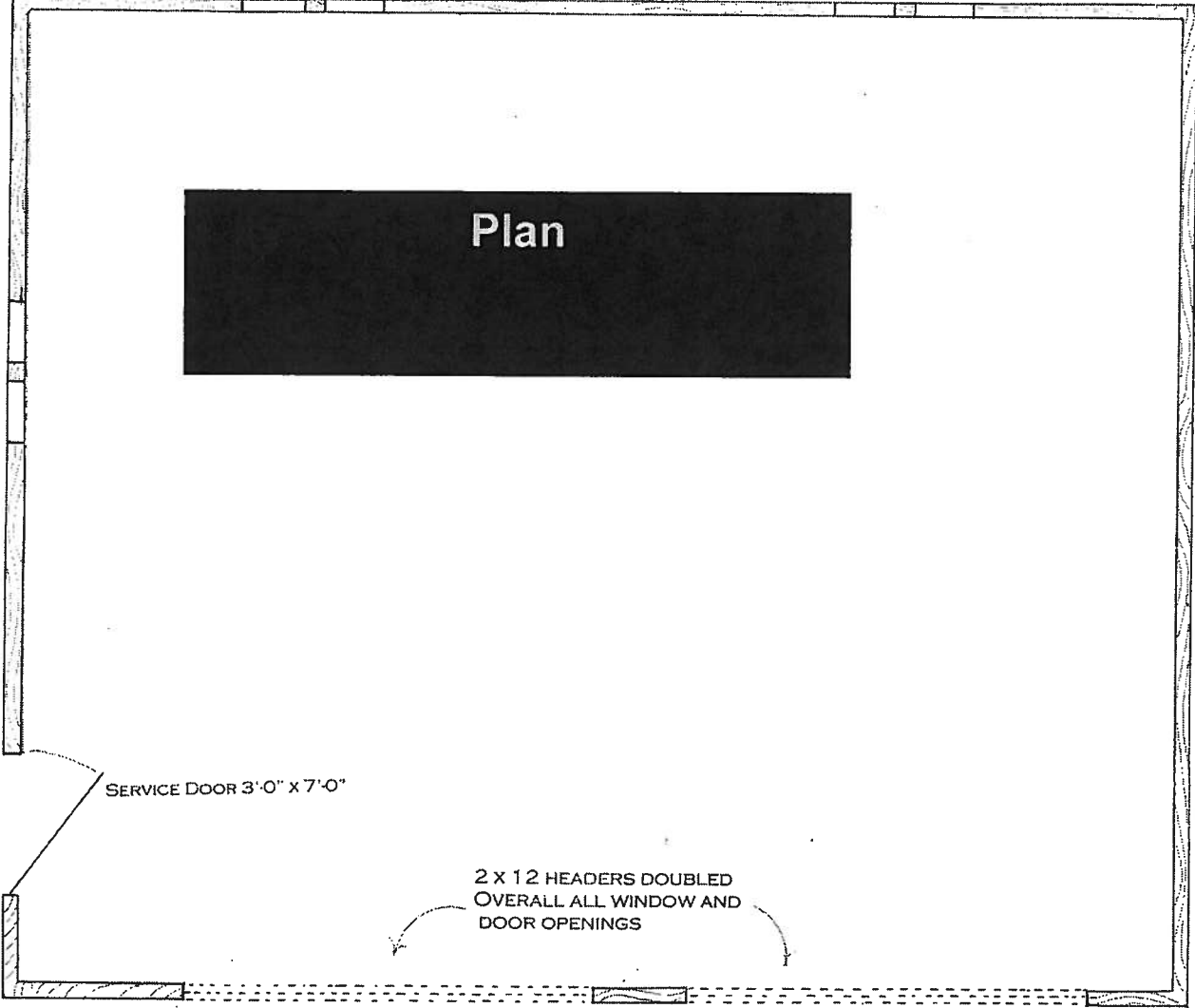

MILWAUKEE, WI 53202
(414) 286-5712

The Bellevue, a
2-1/2 car garage
Floor Plan
&
Section Details

FRIEZE BOARD
BETWEEN FIRST
AND SECOND STORY

FULL SIZE

WALL SHEATHING

FLARED WOOD SHINGLE WITH
BLOCKING BEHIND

#CN-593
CROWN SPECIALTY MOULDINGS

WATER TABLE

SECTION OF
FLARED COURSE

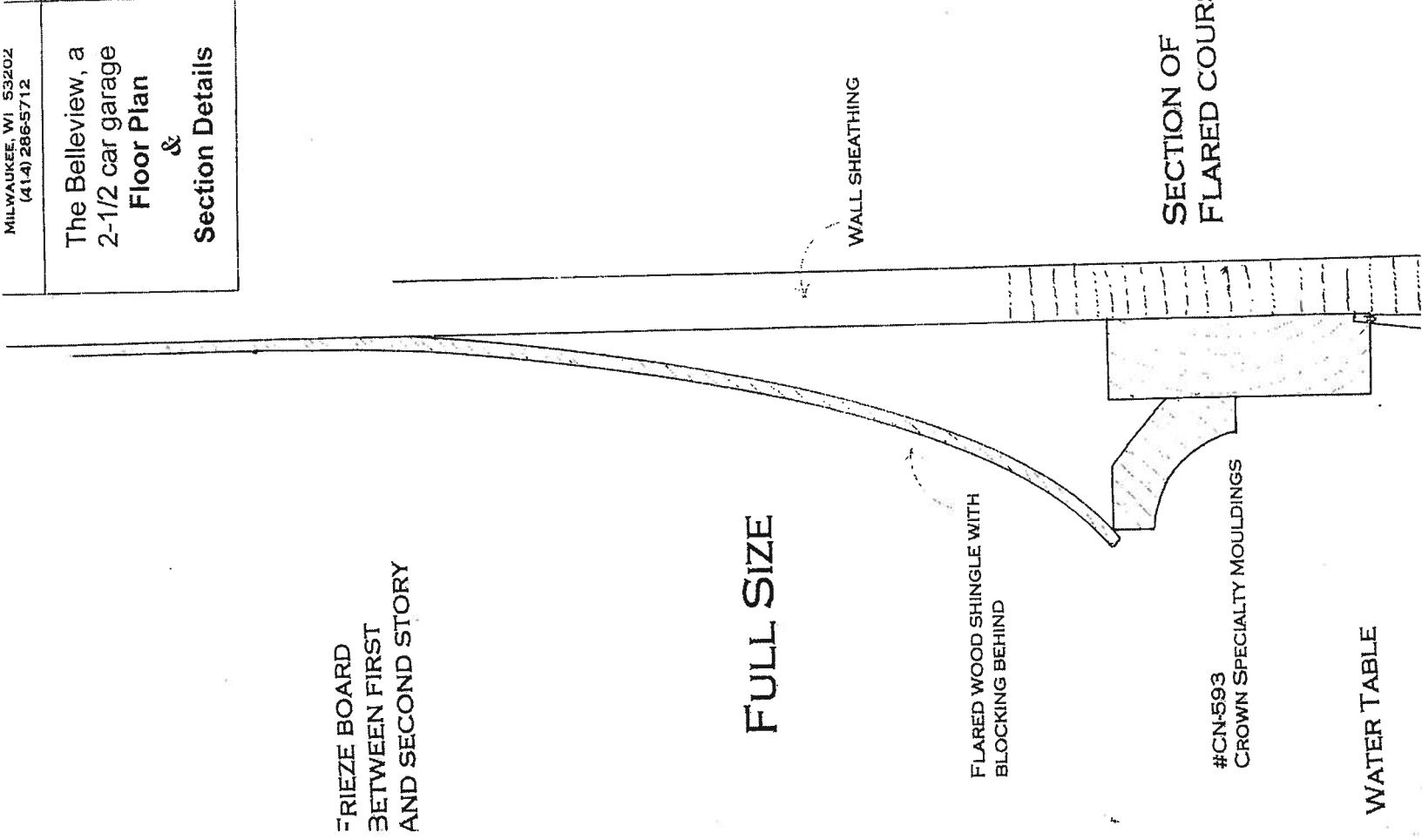

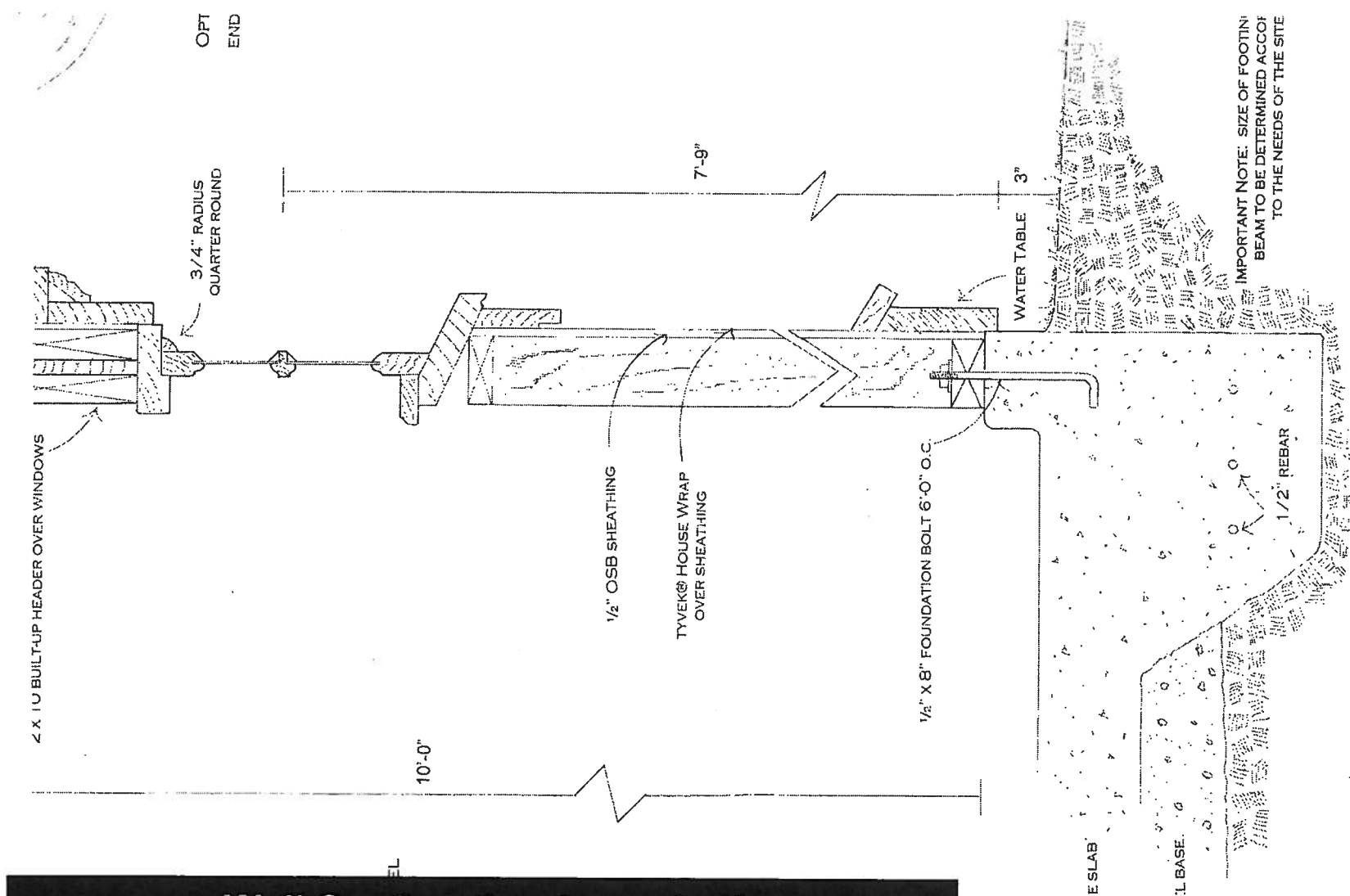

IMPORTANT NOTE: SIZE OF FOOTING BEAM TO BE DETERMINED ACCORDING TO THE NEEDS OF THE SITE

Wall Section thru lower half

Note: If roof is conventionally framed, 2 doug fir floor joists placed 12" on centre square foot load rating for the attic. If truss with the manufacturer to ensure trusses and that they can support at least 40# storage. If the attic is used for an office, rating is necessary and that can be engineered floor joists if the roof is framed by using the properly designed walk-thru

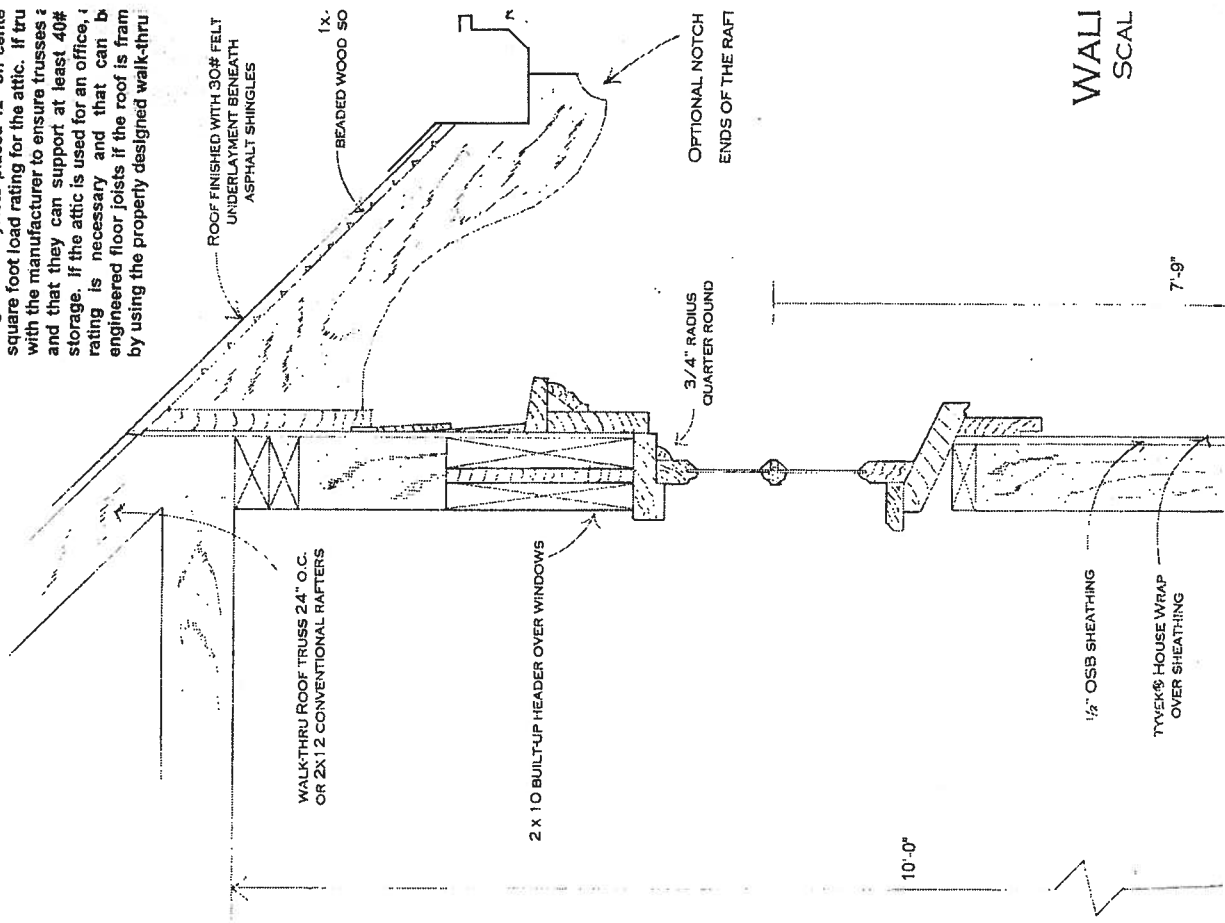

Wall Section thru upper half

WALL
SCAL

CHOOSE EITHER THE CORNER BEAD
DESIGN (R) OR THE 1/4 ROUND DETAIL (L).
THE CORNER BEAD DESIGN TYPICALLY
SPEEDS CONSTRUCTION AND GIVES A FINE
FINISHED APPEARANCE.

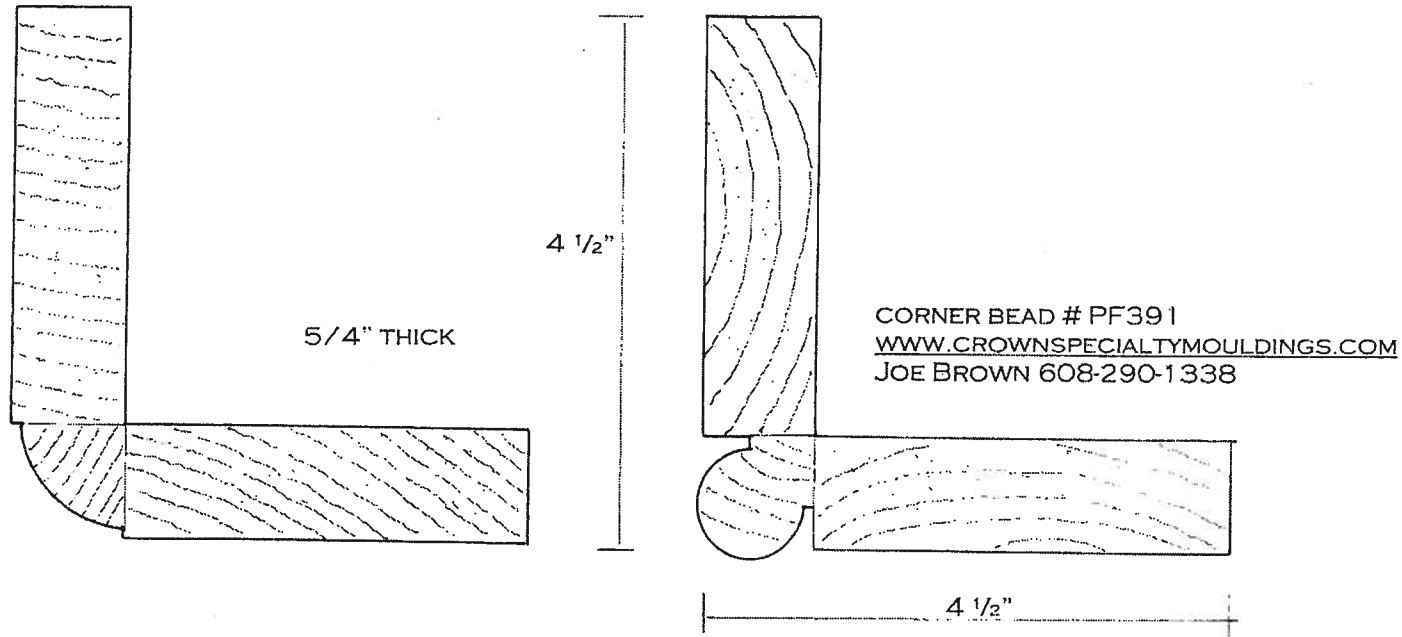

WINDOW AND DOOR TOP
SECTION AND ELEVATION
CORNER BOARD DETAIL

Detail of window and door top

