

Communications and Electrical Conduit and Manholes

Purpose:

Conduit protects and provides a path for communications, traffic and street lighting cables

Manholes provide access points to maintain and pull fiber and copper cables

Types of Conduit Systems

- 1. Communications** – This system provides a path for communications, traffic control and telecommunications and , cable TV cables.
 - Utilized by various City Agencies : DCD, DPW, Fire, Police, Health, Traffic Control.
 - Excess capacity leased to Telecommunications and Cable TV companies.

- 2. Electrical** - This system provides a path for traffic control and street lighting cables.

(Communication cables must remain separate from the higher voltage electrical cables)

Conduit Installations

- Conduit systems are relocated/replaced due to paving conflicts/geometric changes (curb relocation, bridge reconstruction, significant grade changes, etc.)
- Conduit projects are based on prioritized requests received from Communications and Traffic Engineering. These installations include new conduit paths as well as increasing capacity of existing conduit systems.
- Conduit is installed in conjunction with State, County, and local paving projects whenever possible to save on construction costs and cost sharing opportunities on DOT Connecting Highway projects.

Typical Conduit Package Cross-Section

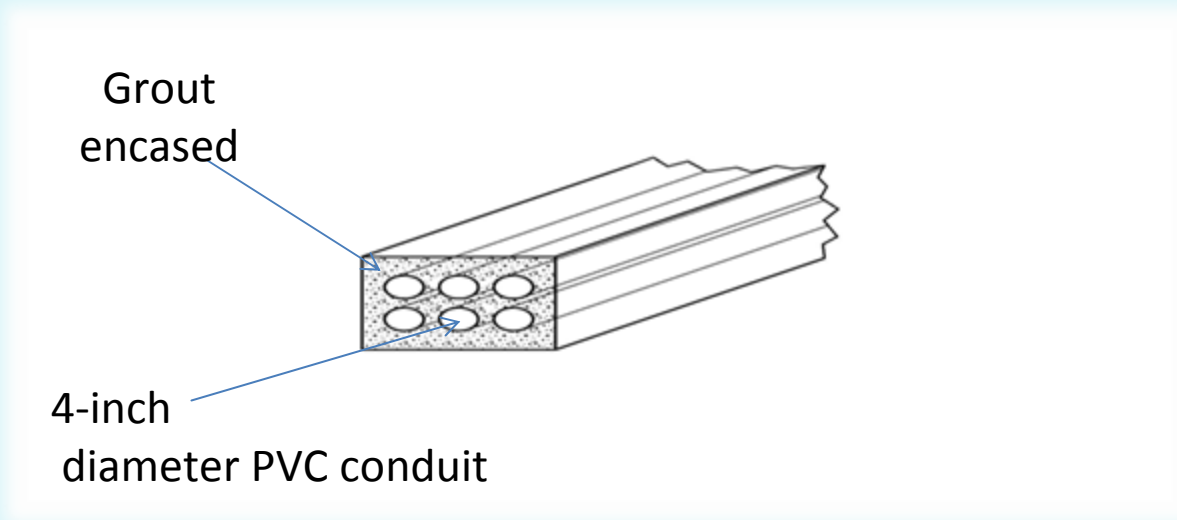

564 miles of conduit, measured end-to-end

9% Iron pile (1888—1905)

19% Clay tile (1905-1930)

55% Fiber (1930—1980)

17% PVC (1980- Present)

Ducts

PVC Pipe in Clay Duct



Fiber Duct



New Conduit with Pull Ropes



Manhole Information

7,543 Active Manholes

43% Brick Manholes (1888 – 1950)

40% Block Manholes (1950 – 1980)*

17% Precast Concrete Manholes (1980 – Present)

* Block manholes fail at a faster rate; no reinforcement used during installation

Block Manhole Repair



Manhole Condition Reports

- Currently manholes are not inspected on a regular schedule
- Inspection record data base created in 1988
- Over 50% of manhole inspection reports are at least 20 years old
- 400 Need to be repaired typically \$2,000 – \$14,000 per manhole
- 200 Need to be replaced typically \$20,000 - \$25,000 per manhole
- Manhole repair/replacement is done while fiber and cable are kept active
- 2011 – Manhole Inspection Contract Let. 301 manhole inspection were completed for paving projects at a cost of \$24,058.44. (\$80.00 per manhole)
- 2012 – Manhole Inspection Contract Let. Price increased to \$67.50/manhole plus \$67.50/dewatering of 70% of the manholes (\$114.75 per manhole)

Manhole Rehab Program

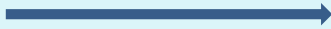
7543 Manhole  100 MHS annually
75 yrs

80 repair	80 @ \$4,700*	= \$376,000
20 replace	<u>20 @ \$23,500*</u>	= <u>\$470,000</u>
	100	\$846,000

Work based upon manhole condition reports:

Repair 400 manholes	@ \$4,700*	= \$1,880,000
Replace 200 manholes	@ \$23,500*	= <u>\$4,700,000</u>
		\$6,580,000

Work based upon useful life cycle (75 years)

Replace 2,000 manholes @ \$23,500* = \$47,000,000

*average cost per 2011 service orders

Budget History

Conduit Installations
New /Replacement

Manhole Rehab
(Repair/Replace)

2012	1,156,000	300,000
2011	800,000	200,000
2010	1,000,000	200,000
2009	400,000	200,000
2008	400,000	200,000
2007	400,000	200,000

Conduit Key Issues

- **Major Projects** in addition to the normal paving program
 - Streetcar Project
 - Zoo Interchange Project
 - DOT Bridge Rehab Projects
- **Manhole Inspection**
 - Develop manhole inspection program on a 5 to 10 year cycle
- **Manhole Maintenance**
 - Develop a regular replacement/repair program based on the manhole inspection condition reports