

# EIGHTEEN87 ON WATER

1887 N. WATER STREET  
MILWAUKEE, WI 53202

07/20/2021

## SPROZ SUBMITTAL



T 414.220.9640  
751 N Jefferson St.  
Suite 200  
Milwaukee, WI 53202

CONSULTANTS:

**CAP PROJECT #: 210502**

**OWNER:  
RULE ENTERPRISES**

1023 SOUTH 26TH STREET  
MILWAUKEE, WI 53204

**CONSULTING ARCHITECT:  
CONTINUUM ARCHITECTS + PLANNERS, S.C.**

751 N JEFFERSON ST - SUITE 200  
MILWAUKEE, WI 53202  
TEL. (414) 220-9640

**CONSULTING CIVIL ENGINEER:  
THE SIGMA GROUP**

1300 W. CANAL STREET  
MILWAUKEE, WI 53233  
TEL. (414) 643-4163

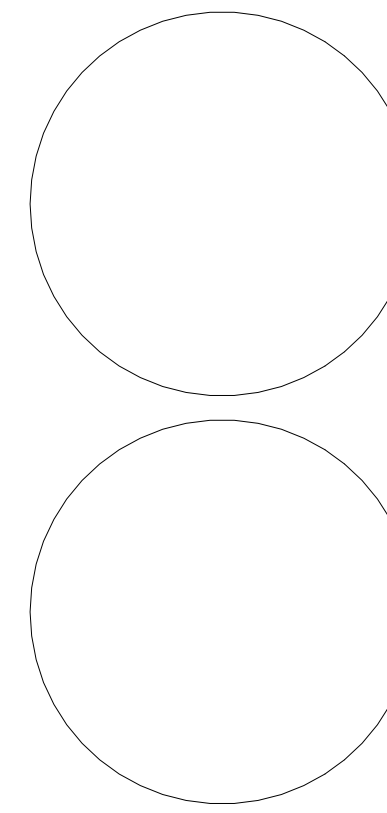

**SHEET INDEX:**

T000	TITLE SHEET
	PLAT OF SURVEY
C002	EROSION CONTROL
C100	SITE PLAN
C200	GRADING PLAN
L100	LANDSCAPE PLAN
EX1	RIVERWALK SITE PLAN EXHIBIT
A200	RIVERWALK STRUCTURAL FRAMING PLAN
A201	SITE PLAN
A202	RIVERWALK PERSPECTIVES
A203	RIVERWALK PERSPECTIVES
A204	RIVERWALK PERSPECTIVES
A205	RIVERWALK PERSPECTIVES
A400	WEST ELEVATIONS & BUILDING SECTIONS
A401	NORTH & EAST ELEVATIONS
A501	NOT USED
A502	WEST BUILDING PERSPECTIVE
A503	NORTH BUILDING PERSPECTIVE
A504	EAST BUILDING PERSPECTIVE

**continuum**  
ARCHITECTS + PLANNERS

**NOT FOR CONSTRUCTION**  
THESE DRAWINGS ARE RELEASED FOR  
DESIGN DEVELOPMENT PURPOSES  
ONLY. THEY ARE NOT TO BE USED FOR  
REGULATORY APPROVAL, PERMIT, OR  
CONSTRUCTION PURPOSES.

EIGHTEEN87 ON WATER

1887 N. WATER STREET  
MILWAUKEE, WI 53202

SHEET TITLE:  
TITLE SHEET SPROZ

REVISIONS:

SCALE	VARIES
PROJECT NUMBER	210502
SET TYPE	SPROZ SUBMITTAL
DATE ISSUED	07/20/2021
SHEET NUMBER	<b>T-000</b>

Programming  
Campus + Master Planning  
Interior Design  
Sustainable Design  
Historic Preservation/  
Renovation  
Project Management

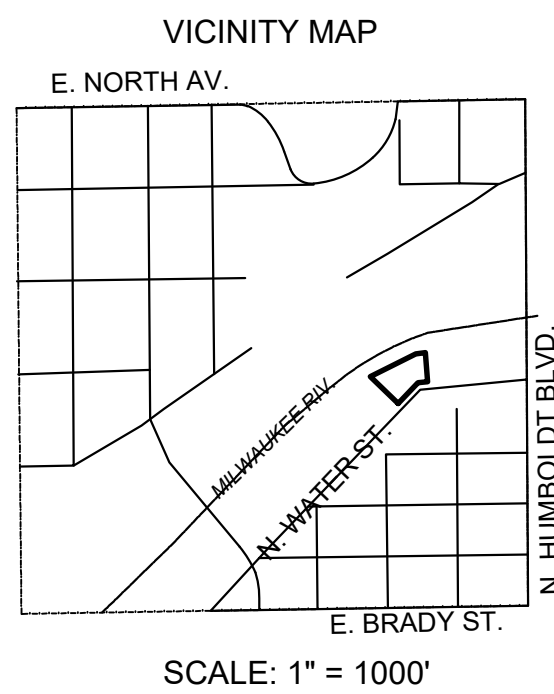

Legal description per First American Title Insurance Company Commitment No. NCS-1070057-MAD, effective date of May 17, 2021:

Water Lots 10, 11, 12, and 13 in Hubbard and Pearson's Addition to Milwaukee, in the Northwest 1/4 of Section 21, Town 7 North, Range 22 East, in the City of Milwaukee, County of Milwaukee, State of Wisconsin.

Tax Key No.: 354-0913-110-5

Address: 1887 N. Water Street

Per First American Title Insurance Company Commitment No. NCS-1070057-MAD, effective date of May 17, 2021, the following items appear in Schedule B II as exceptions:

9. Public or private rights in such portion of the subject premises as may be presently used, laid out or dedicated in any manner whatsoever, for street, highway, and or alley purposes.

10. Rights of the public in any portion of the subject premises lying below the ordinary high water mark of any creek, river, stream, pond, lake or other public body of water. The policy will not insure the exact location of any portion of the land created by the gradual buildup of the shore (accretion), or the lowering of the water level (reliction); the title to the land cut off by a change in course of the water body (avulsion); or ownership of artificially filled land. DOCK LINE SHOWN PER CH. 118-1 CITY OF MILWAUKEE ORDINANCE.

11. Easements, dedications, reservations, provisions, relinquishments, recitals, certificates, and any other matters as provided for or delineated on Plat of Hubbard and Pearson's Addition recorded December 27, 1838 as Document No. PL001009 referenced in the legal description contained herein. Reference is hereby made to said plat for particulars. **BLANKET IN NATURE, NOT PLOTTABLE.**

12. Sewer Easement to City of Milwaukee, a municipal corporation, dated April 26, 1915, recorded/ filed January 18, 1963 in Reel 64, Image 908 as Document No. 4000144. **SHOWN ON MAP.**

13. Utility Easement to Wisconsin Electric Power Company and Wisconsin Telephone Company, dated April 05, 1963, recorded/ filed April 19, 1963 in Reel 95, Image 868 as Document No. 4017101. **SHOWN ON MAP.**

14. Sewer Easement to Milwaukee Metropolitan Sewerage District (MMSD), dated July 25, 1988, recorded/ filed October 31, 1988 in Reel 2269, Image 1078 as Document No. 6222410. **SHOWN ON MAP.**

15. Terms, provisions, restrictions, obligations as set forth in Redevelopment Plan for the Beer Line Redevelopment Project "B" Area adopted on May 03, 1993 by the Redevelopment Authority of the City of Milwaukee recorded on August 17, 1993 in Reel 3099, Image 1747 as Document No. 6813328. Modification and/or amendment by instrument: Redevelopment Plan Amendment No. 1 Recording Information: August 25, 2000 as Document No. 7953564 **BLANKET IN NATURE, NOT PLOTTABLE.**

**NOTES:**

- Bearings are referenced to the East line of the NW 1/4 of Section 21-7-22, bearing North 0°18'59" West.
- Flood Zone classification: Part of the property lies within flood Zone AE. The Zone AE line is shown per FEMA FIRM Panel 55079C0092E, dated 9/26/08 with a Base Flood Elevation determined to be 584.55 NGVD.
- Parcel Area: 41,104 SQUARE FEET OR 0.944 ACRES.
- Vertical Datum: Elevations referenced to the City of Milwaukee Datum with the City Standard Benchmark located 180' north of the north curb of E. Kane Place and 5' west of the west curb of N. Warren St. having a published elevation of 67.824.
- No Zoning Report provided.

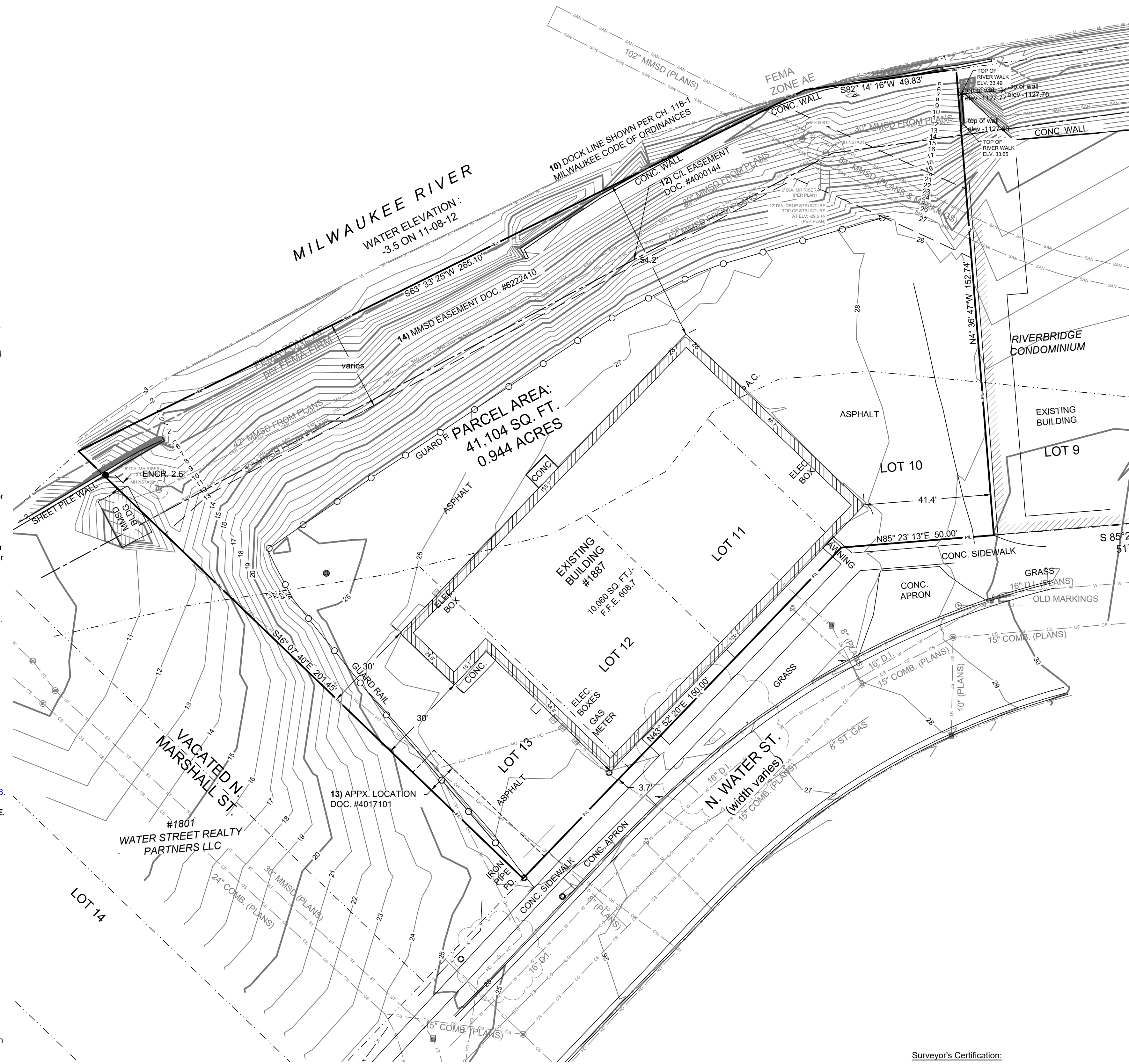

**LEGEND**

---	SECTION 1/4 SECTION LINE	---	EXISTING CONTOUR
---	PROPERTY LINE	○	MANHOLE
---	EASEMENT	○	CATCH BASIN
-x-x-	CHAIN LINK FENCE	○	CATCH BASIN (ROUND)
~	TREE LINE	○	ROOF DRAIN
OH	OVERHEAD UTILITY LINE	○	HYDRANT
E	ELECTRIC	○	WATER VALVE
T	TELEPHONE	○	GAS VALVE
FO	FIBER OPTIC	○	UTILITY POLE
CTV	CABLE TV	○	GUY WIRE
SAN	SANITARY SEWER	○	GAS METER
FM	FORCE MAIN	○	ELECTRIC METER
ST	STORM SEWER	○	UTILITY PEDESTAL
W	WATER MAIN	○	TRAFFIC SIGNAL
G	GAS	○	LIGHT POLE
		○	SOIL BORING
		○	MONITORING WELL
		○	IRON PIPE FOUND/SET
		○	REBAR FOUND/SET
		○	CHISELED CROSS FOUND/SET
		○	PK NAIL FOUND/SET
		○	SPIKE/NAIL
		○	MONUMENT
		○	BENCHMARK
		○	SIGN
		○	DECIDUOUS TREE
		○	CONIFEROUS TREE
		○	BUSH
		○	POST

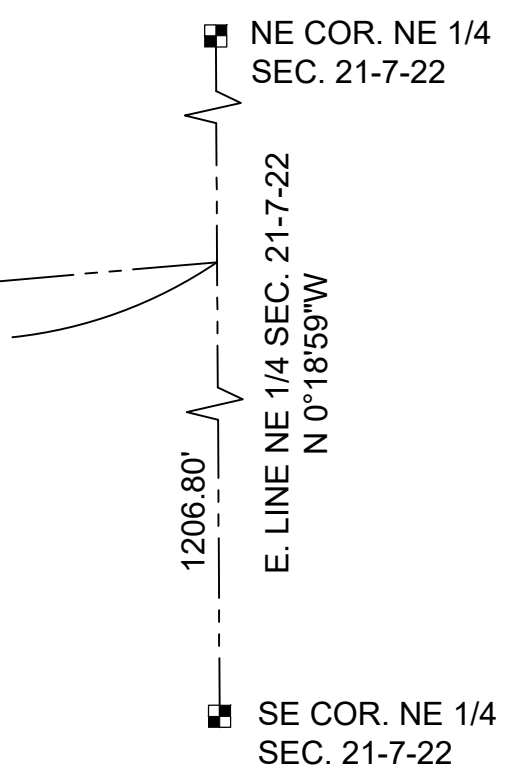

**MANHOLE INFORMATION**

MH NS7A01	RIM: 11.95
	SW 42" INV. -28.06
	NW 102" INV. -41.51
	SE 84" INV. -41.51
MH NS7A02	RIM: 10.14
	NE 42" INV. -9.01
	SW 42" INV. -9.01
MH 00812	RIM: 10.55
	NE 30" INV. -3.41
	SW 30" INV. -3.41

**Surveyor's Certification:**  
 To: Rule Enterprises LLC, a Wisconsin limited liability company  
 First American Title Insurance Company  
 Carl Tomich

This is to certify that this map or plat and the survey on which it is based were made in accordance with the 2021 Minimum Standard Detail Requirements for ALTA/NSPS Land Title Surveys, jointly established and adopted by ALTA and NSPS, and includes items 1, 2, 3, 4, 5, 6(a), 7(a), 8, 11 and 13 of Table A thereof. The field work was completed on March 23, 2021

Date of Map June 2, 2021

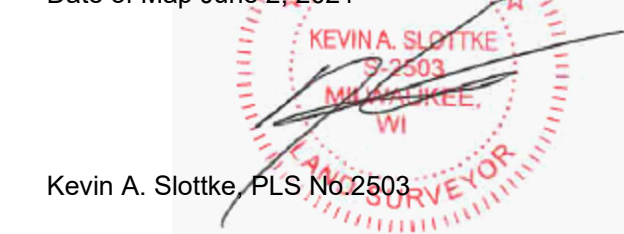

Kevin A. Slotke, PLS No. 2503

**THE SIGMA GROUP**  
 Single Source. Sound Solutions.  
 www.thesigmagroup.com  
 1300 West Canal Street  
 Milwaukee, WI 53233  
 Phone: 414-643-4200  
 Fax: 414-643-4210



1887 N. WATER STREET  
 MILWAUKEE, WISCONSIN

ALTANSPS LAND TITLE SURVEY

NO.	REVISION	DATE	BY
-----	----------	------	----

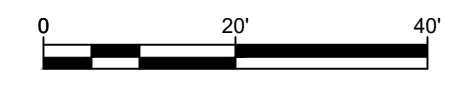

DRAWING NO.	19863-ALTA.dwg
DRAWN BY:	B.M.R.
DATE:	6/02/2021
PROJECT NO:	19863
CHECKED BY:	
APPROVED BY:	
SHEET NO.:	

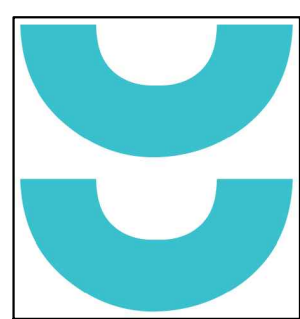

T 414.220.9640  
751 N Jefferson St.  
Suite 200  
Milwaukee, WI 53202

CONSULTANTS:

©COPYRIGHT 2020, CONTINUUM ARCHITECTS + PLANNERS, S.C.

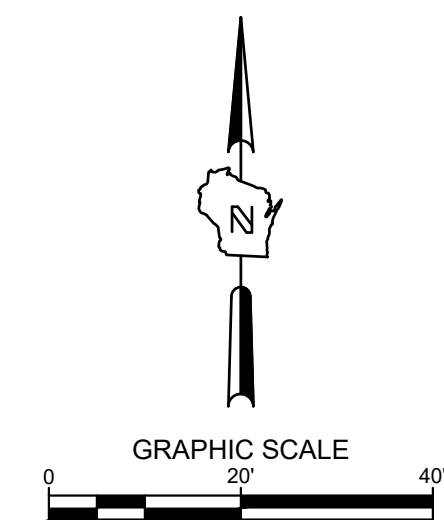
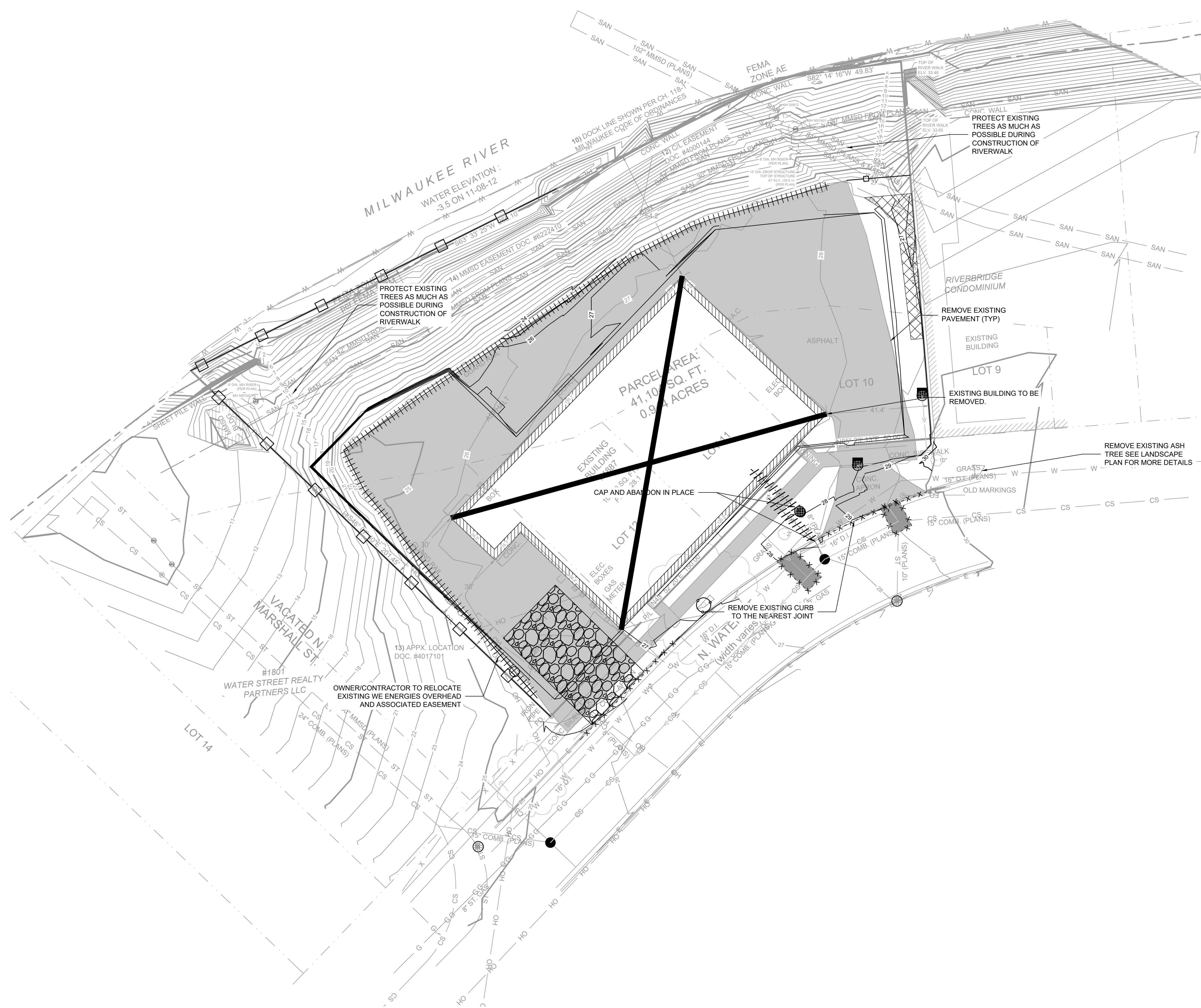

- LEGEND:**
- PROPOSED SILT FENCE (B/C400)
  - PROPOSED INLET PROTECTION (A/C400)
  - PROPOSED TRACKING PAD (E/C400)
  - SEDIMENT LOG/ SILT SOCK (D/C400)
  - PROPOSED EROSION MATTING WISDOT APPROVED CLASS 1 TYPE B (C/C400)
  - EXISTING CONTOUR
  - PROPOSED CONTOUR
  - UTILITY REMOVAL
  - GUARD RAIL REMOVAL
  - STRUCTURE REMOVAL
  - PAVEMENT REMOVAL
  - TREE PROTECTION (F/C400)
  - LIMITS OF RIVERWALK OVERLAY ZONE (50' LANDWARD OF EXISTING DOCK WALL)
  - EXTENTS OF PROPOSED RIVERWALK
- NOTE: ALL EXISTING STREET SIGNS IN R.O.W. SHALL REMAIN IN PLACE, UNLESS NEEDED TO BE REMOVED FOR CONSTRUCTION ACTIVITIES. IF SIGNS ARE REMOVED FOR CONSTRUCTION ACTIVITIES, THE SIGN SHALL BE REPLACED WHEN CONSTRUCTION ACTIVITIES HAVE COMMENCED.

- GENERAL NOTES:**
- THE UNDERGROUND UTILITY INFORMATION SHOWN ON THIS DRAWING IS BASED ON FIELD LOCATIONS AND/OR RECORDS FURNISHED BY MUNICIPALITIES AND UTILITY COMPANIES. THE LOCATION AND ACCURACY OF WHICH CANNOT BE GUARANTEED. THERE MAY BE ADDITIONAL UNDERGROUND UTILITY INSTALLATIONS WITHIN THE PROJECT AREA THAT ARE NOT SHOWN.
  - VERIFY ACTUAL LOCATIONS AND INVERTS IN THE FIELD. ANY POTENTIAL ERRORS, OMISSIONS, OR DISCREPANCIES SHALL BE BROUGHT TO THE ATTENTION OF THE ENGINEER PRIOR TO PROCEEDING WITH CONSTRUCTION.
  - WORK TO BE COMPLETED IS INDICATED IN BOLD TYPE LINES AND EXISTING CONDITIONS ARE INDICATED BY LIGHT TYPE LINES.
  - ELECTRONIC CIVIL FILES ARE AVAILABLE UPON WRITTEN REQUEST. DO NOT USE ELECTRONIC CIVIL FILES TO LAYOUT FOUNDATIONS, COLUMN LINES, LIGHT POLES, OR OTHER NON CIVIL SITE WORK. REFER TO ARCHITECTURAL DRAWINGS FOR DIMENSIONS OF BUILDING AND ARCHITECTURAL FEATURES.
  - SEE SHEET C400 FOR A COMPLETE LIST OF EROSION CONTROL NOTES AND DETAILS. EROSION CONTROL MEASURES SHALL BE INSTALLED PRIOR TO START OF LAND DISTURBING ACTIVITIES.
  - DO NOT BEGIN LAND DISTURBING ACTIVITIES UNTIL AN EROSION CONTROL PERMIT IS OBTAINED FROM LOCAL JURISDICTION.

**NOT FOR CONSTRUCTION**  
THESE DRAWINGS ARE RELEASED FOR DESIGN DEVELOPMENT PURPOSES ONLY. THEY ARE NOT TO BE USED FOR REGULATORY APPROVAL, PERMIT, OR CONSTRUCTION PURPOSES.

**EIGHTEEN87 ON WATER**  
1887 N WATER STREET  
MILWAUKEE, WI 53202  
SHEET TITLE: EROSION CONTROL

REVISIONS:

SCALE	1" = 20'-0"
PROJECT NUMBER	210502
SET TYPE	SPROZ SUBMITTAL
DATE ISSUED	07/20/21
SHEET NUMBER	<b>C002</b>

**PRELIMINARY  
NOT FOR  
CONSTRUCTION**

SIGMA PROJECT NUMBER 19863



CALL DIGGERS HOTLINE  
1-800-242-8511  
TOLL FREE  
WE STRONGLY RECOMMEND  
NOTICE BEFORE YOU EXCAVATE  
MILW. AREA 259-1181

THE UNDERGROUND UTILITY INFORMATION SHOWN ON THIS MAP IS BASED ON FIELD MARKINGS AND INFORMATION FURNISHED BY UTILITY COMPANIES AND THE LOCAL MUNICIPALITY. WHILE THIS INFORMATION IS BELIEVED TO BE RELIABLE, ITS ACCURACY AND COMPLETENESS CANNOT BE GUARANTEED.

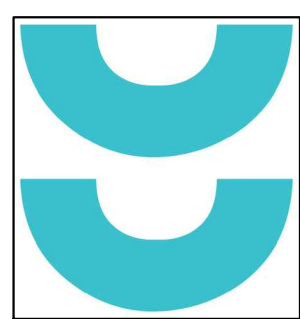

T 414.220.9640  
751 N Jefferson St.  
Suite 200  
Milwaukee, WI 53202

CONSULTANTS:

©COPYRIGHT 2020, CONTINUUM ARCHITECTS + PLANNERS S.C.

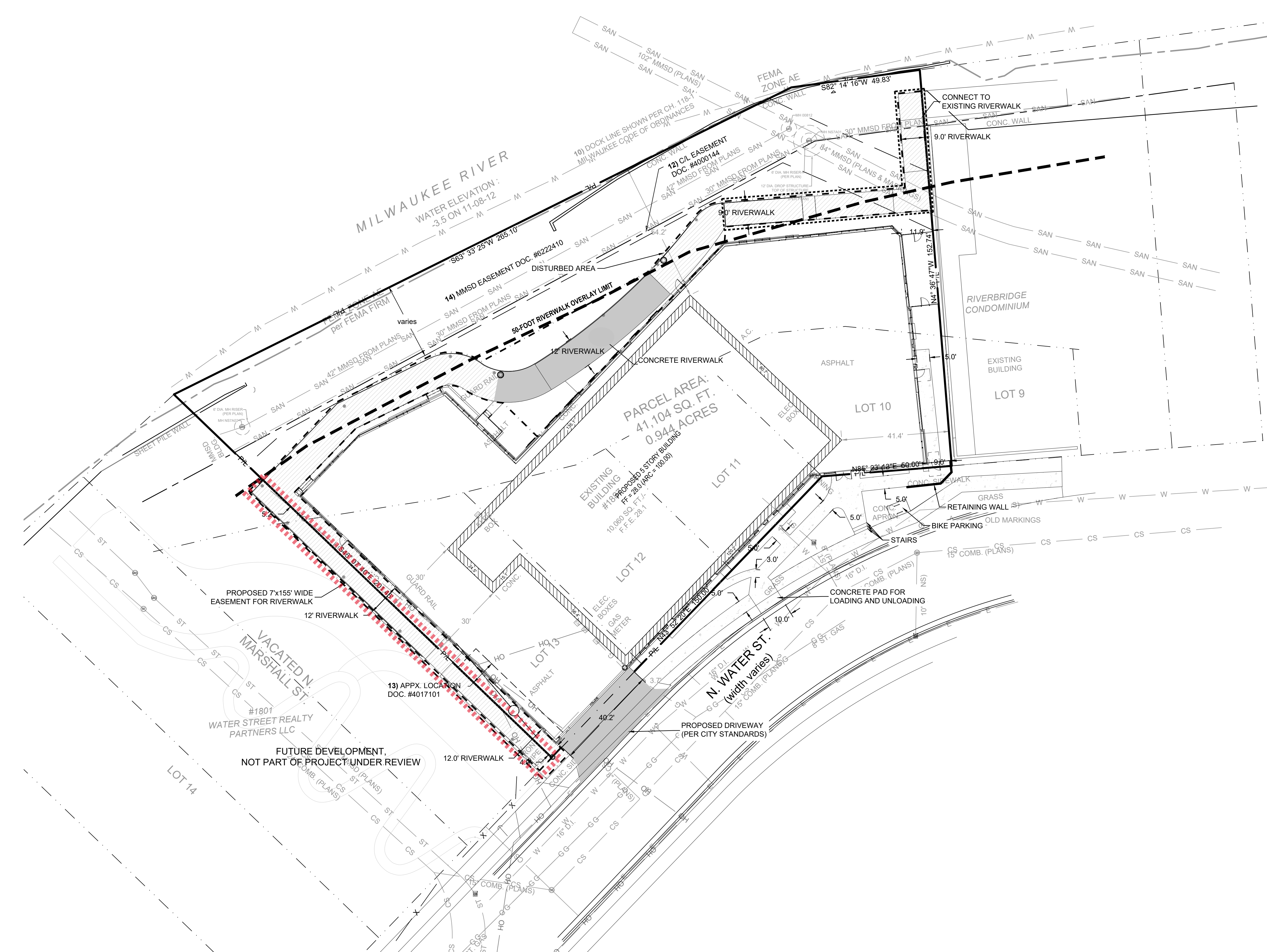
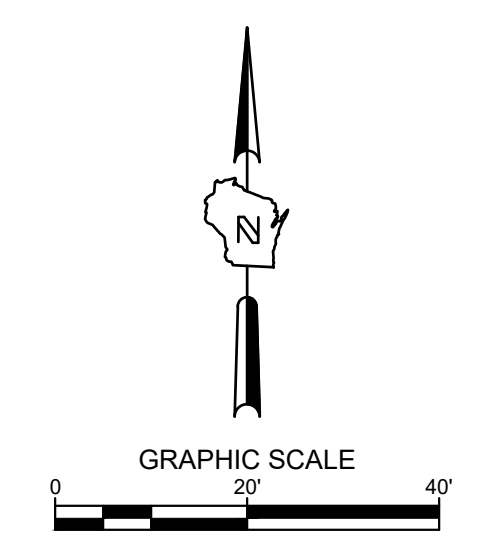

**SITE INFORMATION**

SITE AREA = 41,104 SF (0.944 AC)  
SITE DISTURBED AREA = 34,332 SF (0.788 AC)  
EXISTING IMPERVIOUS AREA = 26,223 SF (0.602 AC)  
PROPOSED IMPERVIOUS AREA = 26,267 SF (0.603 AC)  
PROPOSED RIVERWALK DECK = 3,580 SF (0.082 AC)  
TOTAL PARKING SPACES = 53 SPACES (ALL INSIDE PROPOSED BUILDING)

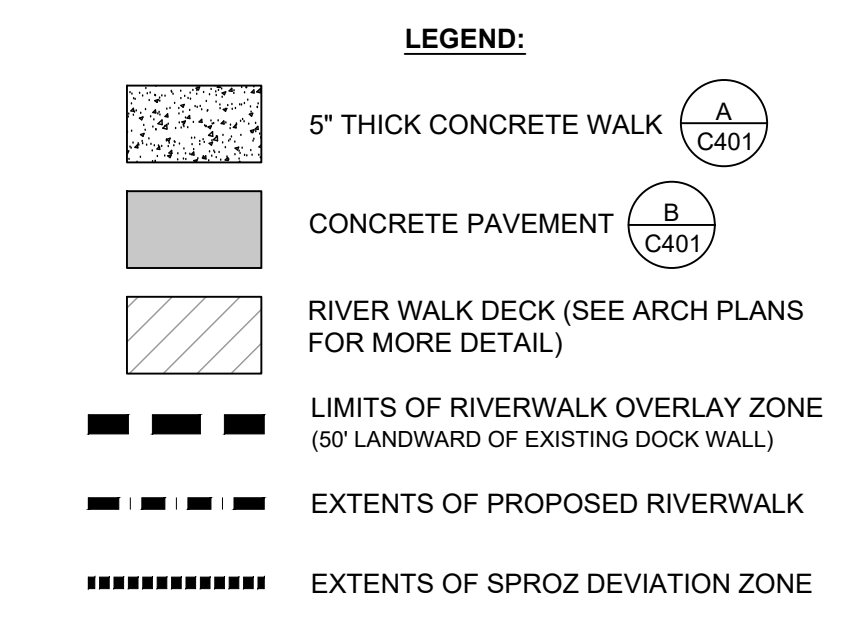

**GENERAL NOTES:**

1. THE UNDERGROUND UTILITY INFORMATION SHOWN ON THIS DRAWING IS BASED ON FIELD LOCATIONS AND/OR RECORDS FURNISHED BY MUNICIPALITIES AND UTILITY COMPANIES. THE LOCATION AND ACCURACY OF WHICH CANNOT BE GUARANTEED. THERE MAY BE ADDITIONAL UNDERGROUND UTILITY INSTALLATIONS WITHIN THE PROJECT AREA THAT ARE NOT SHOWN.
2. VERIFY ACTUAL LOCATIONS AND INVERTS IN THE FIELD. ANY POTENTIAL ERRORS, OMISSIONS, OR DISCREPANCIES SHALL BE BROUGHT TO THE ATTENTION OF THE ENGINEER PRIOR TO PROCEEDING WITH CONSTRUCTION.
3. WORK TO BE COMPLETED IS INDICATED IN BOLD TYPE LINES AND EXISTING CONDITIONS ARE INDICATED BY LIGHT TYPE LINES.
4. ELECTRONIC CIVIL FILES ARE AVAILABLE UPON WRITTEN REQUEST. DO NOT USE ELECTRONIC CIVIL FILES TO LAYOUT FOUNDATIONS, COLUMN LINES, LIGHT POLES, OR OTHER NON CIVIL SITE WORK. REFER TO ARCHITECTURAL DRAWINGS FOR DIMENSIONS OF BUILDING AND ARCHITECTURAL FEATURES.
5. DIMENSIONS ARE FROM FACE OF CURB OR EDGE OF PAVEMENT.
6. WORK WITHIN THE PUBLIC RIGHT OF WAY, INCLUDING BUT NOT LIMITED TO DRIVEWAY OPENINGS, SIDEWALK AND RAMPS, PAVING, AND CURB AND GUTTER SHALL BE COMPLETED PER MUNICIPAL AND/OR COUNTY REQUIREMENTS AND STANDARDS.

**NOT FOR CONSTRUCTION**  
THESE DRAWINGS ARE RELEASED FOR DESIGN DEVELOPMENT PURPOSES ONLY. THEY ARE NOT TO BE USED FOR REGULATORY APPROVAL, PERMIT, OR CONSTRUCTION PURPOSES.

**EIGHTEEN87 ON WATER**

1827 N WATER STREET  
MILWAUKEE, WI 53202  
SHEET TITLE: **SITE PLAN**

REVISIONS:

SCALE	1" = 20'-0"
PROJECT NUMBER	210502
SET TYPE	SPROZ SUBMITTAL
DATE ISSUED	07/20/21
SHEET NUMBER	<b>C100</b>

**PRELIMINARY NOT FOR CONSTRUCTION**

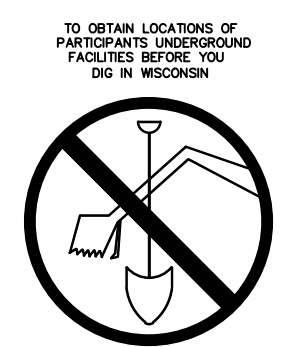

CALL DIGGERS HOTLINE  
TOLL FREE  
1-800-242-8511

THE UNDERGROUND UTILITY INFORMATION SHOWN ON THIS MAP IS BASED ON FIELD MARKINGS AND INFORMATION FURNISHED BY UTILITY COMPANIES AND THE LOCAL MUNICIPALITY. WHILE THIS INFORMATION IS BELIEVED TO BE RELIABLE, ITS ACCURACY AND COMPLETENESS CANNOT BE GUARANTEED.

MILWAUKEE AREA 259-1181

SIGMA PROJECT 19863 NUMBER

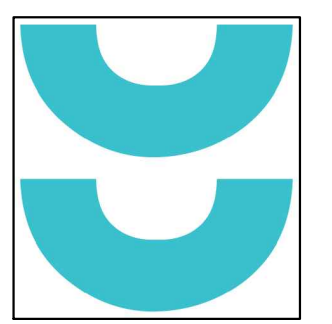

T 414.220.9640  
751 N Jefferson St.  
Suite 200  
Milwaukee, WI 53202

CONSULTANTS:

© COPYRIGHT 2020. CONTINUUM ARCHITECTS + PLANNERS S.C.

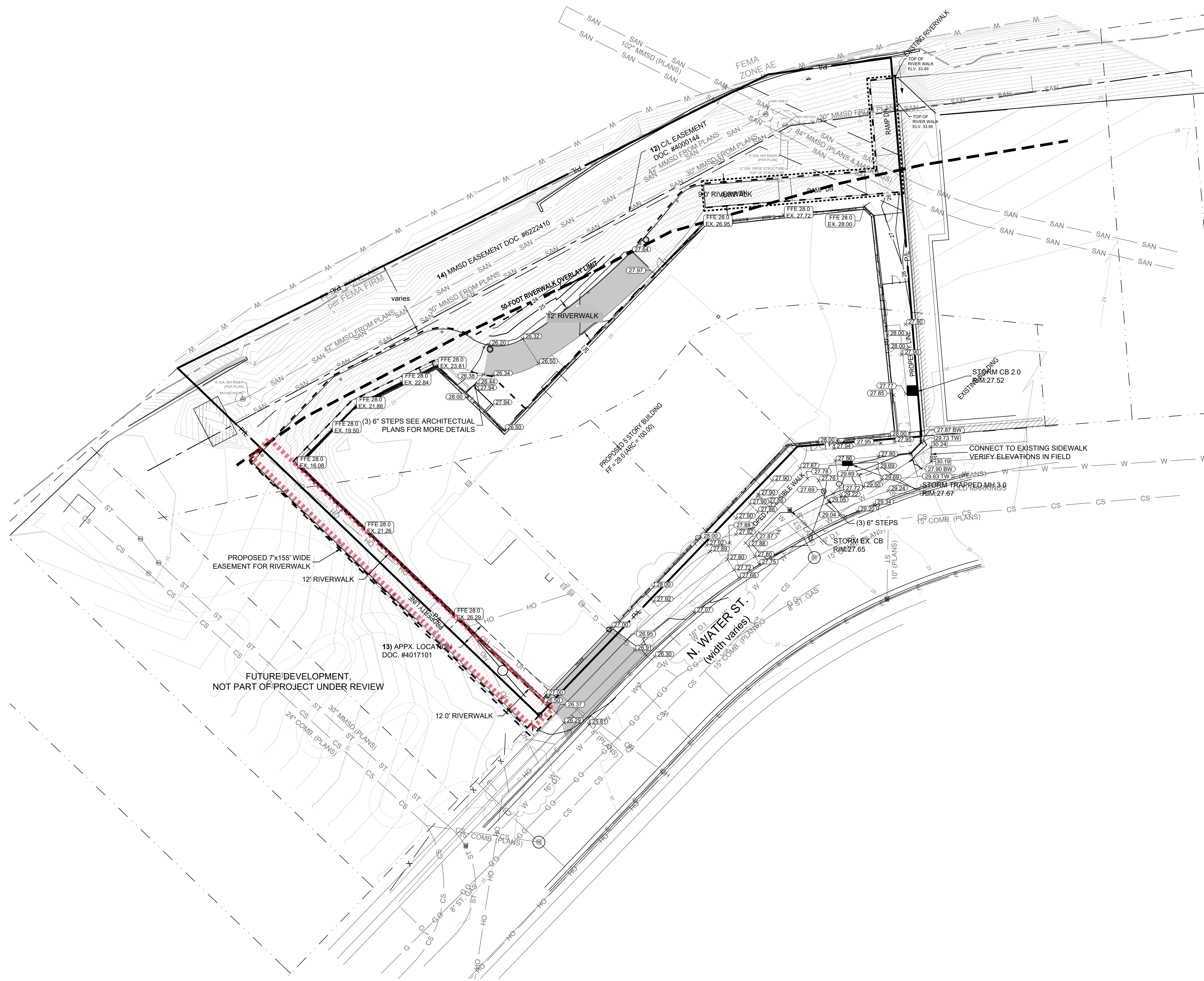

- LEGEND:**
- 5' THICK CONCRETE WALK (A C401)
  - CONCRETE PAVEMENT (B C401)
  - RAISED RIVER WALK (SEE ARC PLANS FOR MORE DETAIL)
  - EXISTING CONTOUR
  - PROPOSED CONTOUR
  - PROPOSED CURB & GUTTER SPOT GRADE  
T/C: TOP OF CURB GRADE  
F/L: FLOW LINE CURB GRADE
  - PROPOSED ASPHALT SPOT GRADE
  - EXISTING SURFACE SPOT GRADE (MATCH)
  - LIMITS OF RIVERWALK OVERLAY ZONE (50' LANDWARD OF EXISTING DOCK WALL)
  - EXTENTS OF PROPOSED RIVERWALK
  - EXTENTS OF SPROZ DEVIATION ZONE

- GENERAL NOTES:**
1. THE UNDERGROUND UTILITY INFORMATION SHOWN ON THIS DRAWING IS BASED ON FIELD LOCATIONS AND/OR RECORDS FURNISHED BY MUNICIPALITIES AND UTILITY COMPANIES. THE LOCATION AND ACCURACY OF WHICH CANNOT BE GUARANTEED. THERE MAY BE ADDITIONAL UNDERGROUND UTILITY INSTALLATIONS WITHIN THE PROJECT AREA THAT ARE NOT SHOWN.
  2. VERIFY ACTUAL LOCATIONS AND INVERTS IN THE FIELD. ANY POTENTIAL ERRORS, OMISSIONS, OR DISCREPANCIES SHALL BE BROUGHT TO THE ATTENTION OF THE ENGINEER PRIOR TO PROCEEDING WITH CONSTRUCTION.
  3. WORK TO BE COMPLETED IS INDICATED IN BOLD TYPE LINES AND EXISTING CONDITIONS ARE INDICATED BY LIGHT TYPE LINES.
  4. ELECTRONIC CIVIL FILES ARE AVAILABLE UPON WRITTEN REQUEST. DO NOT USE ELECTRONIC CIVIL FILES TO LAYOUT FOUNDATIONS, COLUMN LINES, LIGHT POLES, OR OTHER NON CIVIL SITE WORK. REFER TO ARCHITECTURAL DRAWINGS FOR DIMENSIONS OF BUILDING AND ARCHITECTURAL FEATURES.
  5. DIMENSIONS ARE FROM FACE OF CURB OR EDGE OF PAVEMENT.
  6. WORK WITHIN THE PUBLIC RIGHT OF WAY, INCLUDING BUT NOT LIMITED TO DRIVEWAY OPENINGS, SIDEWALK AND RAMPS, PAVING, AND CURB AND GUTTER SHALL BE COMPLETED PER MUNICIPAL AND/OR COUNTY REQUIREMENTS AND STANDARDS.
  7. EARTHWORK SHALL BE IN ACCORDANCE WITH GEOTECHNICAL ENGINEER'S RECOMMENDATIONS.

**NOT FOR CONSTRUCTION**  
THESE DRAWINGS ARE RELEASED FOR DESIGN DEVELOPMENT PURPOSES ONLY. THEY ARE NOT TO BE USED FOR REGULATORY APPROVAL, PERMIT, OR CONSTRUCTION PURPOSES.

EIGHTEEN87 ON WATER

1827 N. WATER STREET  
MILWAUKEE, WI 53202

SHEET TITLE:  
GRADING PLAN

REVISIONS:

SCALE	1" = 20'-0"
PROJECT NUMBER	210502
SET TYPE	SPROZ SUBMITTAL
DATE ISSUED	07/20/21
SHEET NUMBER	<b>C200</b>

SIGMA PROJECT NUMBER 19863

**PRELIMINARY  
NOT FOR  
CONSTRUCTION**

THE UNDERGROUND UTILITY INFORMATION SHOWN ON THIS MAP IS BASED ON FIELD MARKINGS AND INFORMATION FURNISHED BY UTILITY COMPANIES AND THE LOCAL MUNICIPALITY. WHILE THIS INFORMATION IS BELIEVED TO BE RELIABLE, ITS ACCURACY AND COMPLETENESS CANNOT BE GUARANTEED.



CALL DIGGERS HOTLINE  
1-800-242-8511  
TOLL FREE  
WE STRIVE TO GIVE YOU THE MOST ACCURATE AND COMPLETE INFORMATION AVAILABLE. MILWAUKEE AREA 259-1181

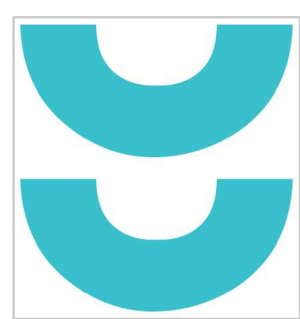

T 414.220.9640  
751 N Jefferson St.  
Suite 200  
Milwaukee, WI 53202

CONSULTANTS:

©COPYRIGHT 2020, CONTINUUM ARCHITECTS + PLANNERS S.C.

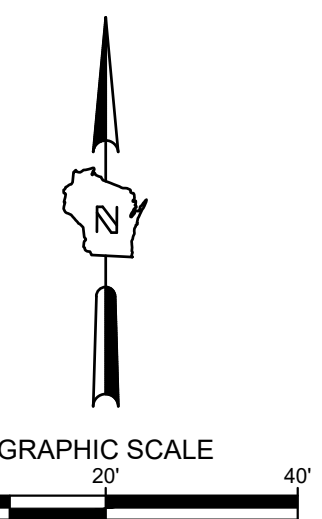
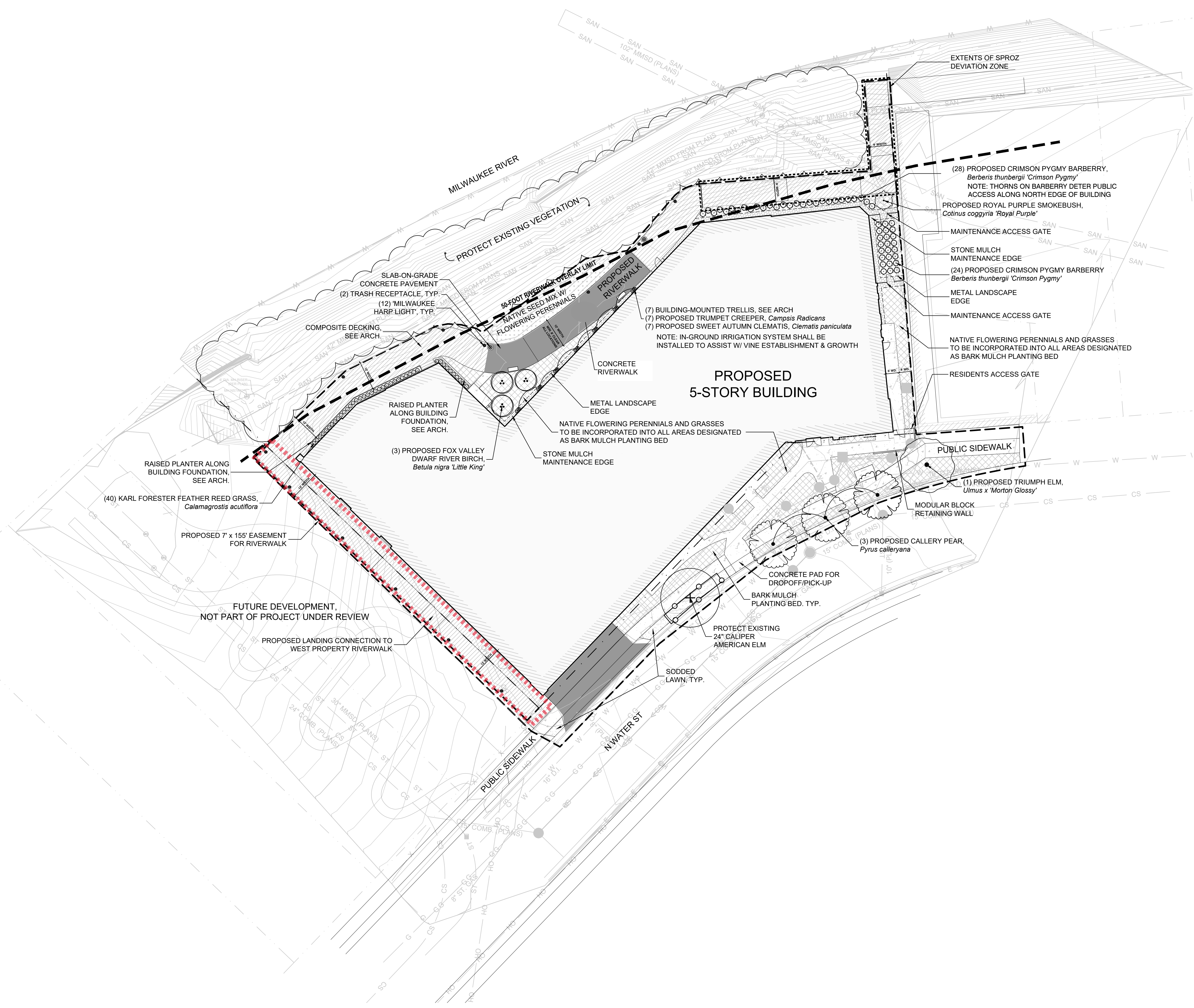

- GENERAL NOTES:**
- IT IS THE CONTRACTORS RESPONSIBILITY TO FIELD VERIFY SURVEY INFORMATION AND SITE CONDITIONS PRIOR TO START OF CONSTRUCTION AND REPORT ANY DISCREPANCIES. CONTRACTOR SHALL CONTACT DIGGER'S HOTLINE TO LOCATE ALL PUBLIC AND PRIVATE UTILITIES PRIOR TO THE START OF CONSTRUCTION. ANY DAMAGE CAUSED TO EXISTING UTILITIES, EITHER SHOWN OR NOT, SHALL BE REPAIRED AND PAID FOR AT THE CONTRACTORS EXPENSE.
  - CONTRACTOR SHALL PROTECT ALL BENCHMARKS.
  - ALL EXISTING PLANT MATERIAL IS SHOWN AT EXISTING, APPROXIMATED SIZE.
  - ALL WRAPPINGS, WIRE BASKETS, BURLAP, AND OTHER MISCELLANEOUS MATERIAL SHALL BE COMPLETELY REMOVED FROM ALL SHRUB AND TREE ROOT BALLS PRIOR TO INSTALLATION.
  - ANY LAWN OR LANDSCAPED AREAS OUTSIDE OF THE CONSTRUCTION BOUNDARY THAT ARE DISTURBED SHALL BE RE-SEEDDED AND/OR REPAIRED WITH ORIGINAL MATERIALS AND PRE-DISTURBANCE STANDARDS AT NO COST TO THE OWNER OR CITY.
  - CONTRACTOR IS RESPONSIBLE FOR WATERING AND MAINTENANCE OF PLANT MATERIAL.

- LEGEND:**
- LIMITS OF DISTURBANCE
  - - - PROPERTY LINE
  - - - METAL LANDSCAPE EDGE
  - + EXISTING DECIDUOUS CANOPY TREE
  - PROPOSED DECIDUOUS CANOPY TREE
  - ⊕ PROPOSED DECIDUOUS ORNAMENTAL TREE
  - TREE PROTECTION FENCE
  - ▨ BARK MULCH PLANTING BED
  - ▤ NATIVE SEED MIX
  - ▥ SEEDED LAWN
  - ▧ STONE MULCH

**NOT FOR CONSTRUCTION**  
THESE DRAWINGS ARE RELEASED FOR DESIGN DEVELOPMENT PURPOSES ONLY. THEY ARE NOT TO BE USED FOR REGULATORY APPROVAL, PERMIT, OR CONSTRUCTION PURPOSES.

EIGHTEEN87 ON WATER  
1887 N WATER STREET  
MILWAUKEE, WI 53202  
SHEET TITLE: LANDSCAPE OVERVIEW

REVISIONS:

SCALE	1" = 20'-0"
PROJECT NUMBER	210502
SET TYPE	SPROZ SUBMITTAL
DATE ISSUED	07/20/21
SHEET NUMBER	<b>L100</b>

**PRELIMINARY  
NOT FOR  
CONSTRUCTION**

SIGMA PROJECT NUMBER 19863



CALL DIGGER'S HOTLINE  
TOLL FREE  
1-800-242-8011

THE UNDERGROUND UTILITY INFORMATION SHOWN ON THIS MAP IS BASED ON FIELD MARKINGS AND INFORMATION FURNISHED BY UTILITY COMPANIES AND THE LOCAL MUNICIPALITY. WHILE THIS INFORMATION IS BELIEVED TO BE RELIABLE, ITS ACCURACY AND COMPLETENESS CANNOT BE GUARANTEED.

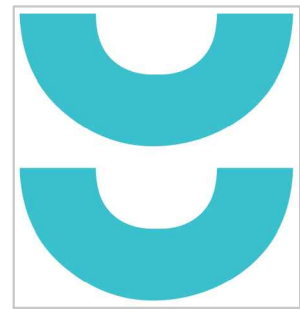

T 414.220.9640  
751 N Jefferson St.  
Suite 200  
Milwaukee, WI 53202

CONSULTANTS:

**NOT FOR CONSTRUCTION**  
THESE DRAWINGS ARE RELEASED FOR DESIGN DEVELOPMENT PURPOSES ONLY. THEY ARE NOT TO BE USED FOR REGULATORY APPROVAL, PERMIT, OR CONSTRUCTION PURPOSES.

EIGHTEEN87 ON WATER  
1887 N WATER STREET  
MILWAUKEE, WI 53202  
SHEET TITLE:  
RIVERWALK SITE PLAN EXHIBIT

REVISIONS:

SCALE	1" = 20'-0"
PROJECT NUMBER	210502
SET TYPE	SPROZ SUBMITTAL
DATE ISSUED	07/20/21
SHEET NUMBER	<b>EX1</b>

**LEGEND:**

- LIMITS OF RIVERWALK OVERLAY ZONE (5' LANDWARD OF EXISTING DOCK WALL)
- EXTENTS OF PROPOSED RIVERWALK
- SPROZ DEVIATION ZONE
- PROPERTY LINE
- METAL LANDSCAPE EDGE
- + EXISTING DECIDUOUS CANOPY TREE
- PROPOSED DECIDUOUS CANOPY TREE
- ⊙ PROPOSED DECIDUOUS ORNAMENTAL TREE
- TREE PROTECTION FENCE
- ▨ BARK MULCH PLANTING BED
- ▩ NATIVE SEED MIX
- ▩ SEEDED LAWN
- ▩ STONE MULCH

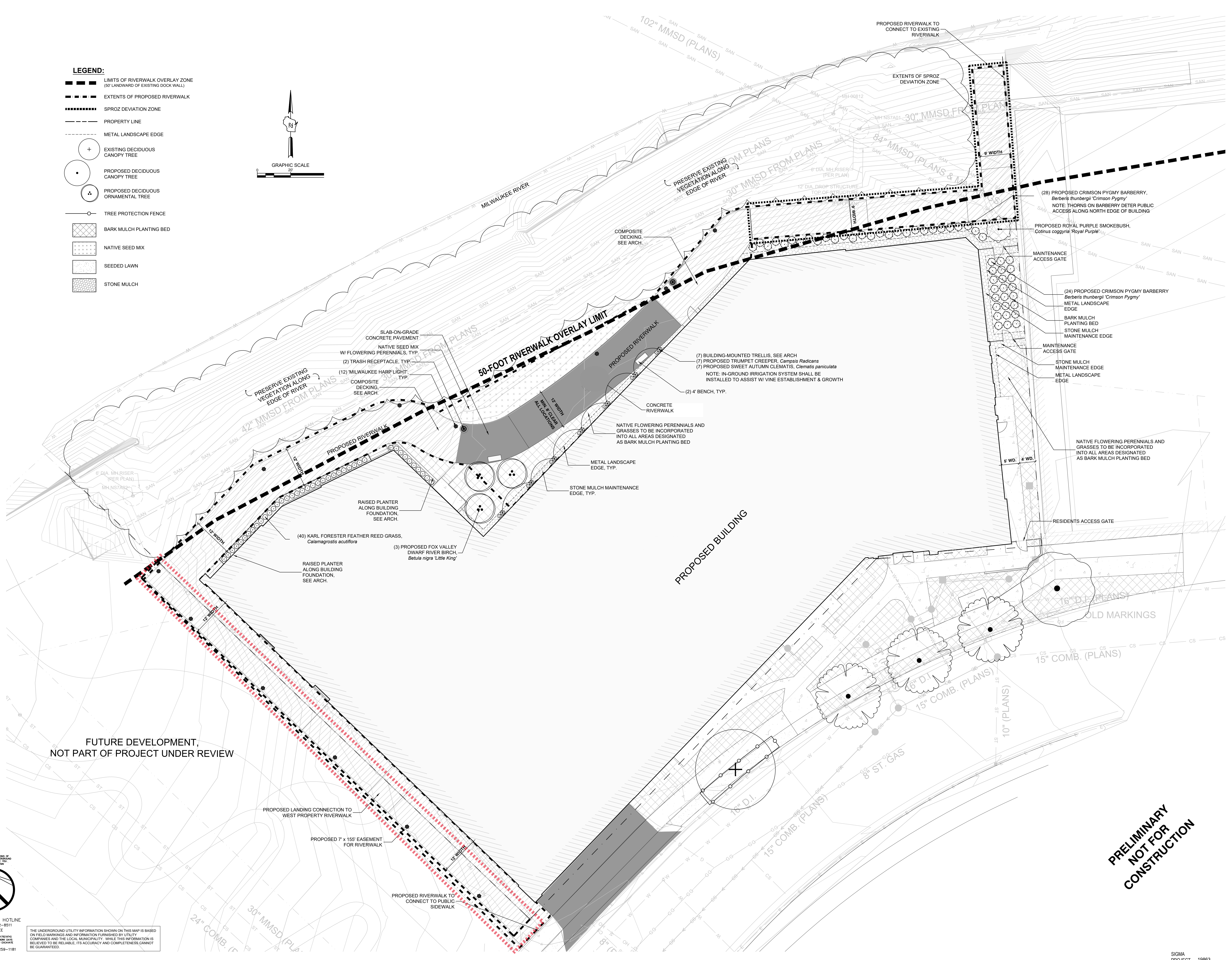
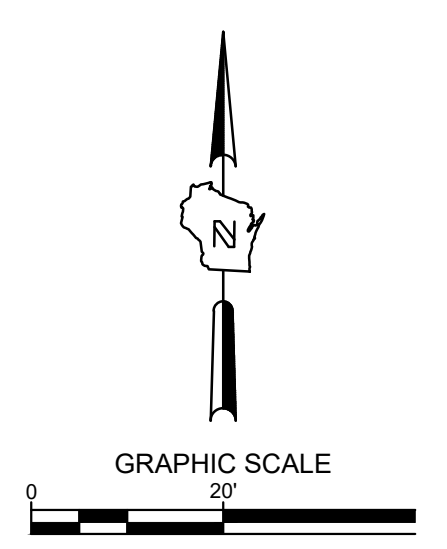

FUTURE DEVELOPMENT,  
NOT PART OF PROJECT UNDER REVIEW

**PRELIMINARY  
NOT FOR  
CONSTRUCTION**



CALL DIGGERS HOTLINE  
1-800-242-8011  
TOLL FREE  
WE STATE NO WARRANTY  
REGARDING THE LOCATION,  
DEPTH, OR CHARACTER OF  
UTILITIES SHOWN ON THIS MAP.  
MILW. AREA 259-1181

THE UNDERGROUND UTILITY INFORMATION SHOWN ON THIS MAP IS BASED ON FIELD MARKINGS AND INFORMATION FURNISHED BY UTILITY COMPANIES AND THE LOCAL MUNICIPALITY. WHILE THIS INFORMATION IS BELIEVED TO BE RELIABLE, ITS ACCURACY AND COMPLETENESS CANNOT BE GUARANTEED.

SIGMA PROJECT NUMBER 19863



T 414.220.9640  
751 N Jefferson St.  
Suite 200  
Milwaukee, WI 53202

CONSULTANTS:

**NOT FOR CONSTRUCTION**  
THESE DRAWINGS ARE RELEASED FOR DESIGN DEVELOPMENT PURPOSES ONLY. THEY ARE NOT TO BE USED FOR REGULATORY APPROVAL, PERMIT, OR CONSTRUCTION PURPOSES.

EIGHTEEN87 ON WATER

1887 N WATER STREET  
MILWAUKEE, WI 53202

SHEET TITLE  
RIVERWALK STRUCTURAL FRAMING PLAN

REVISIONS:

SCALE	VARIES
PROJECT NUMBER	210502
SET TYPE	DPD SUBMITTAL
DATE ISSUED	07/20/21
SHEET NUMBER	<b>A-200</b>

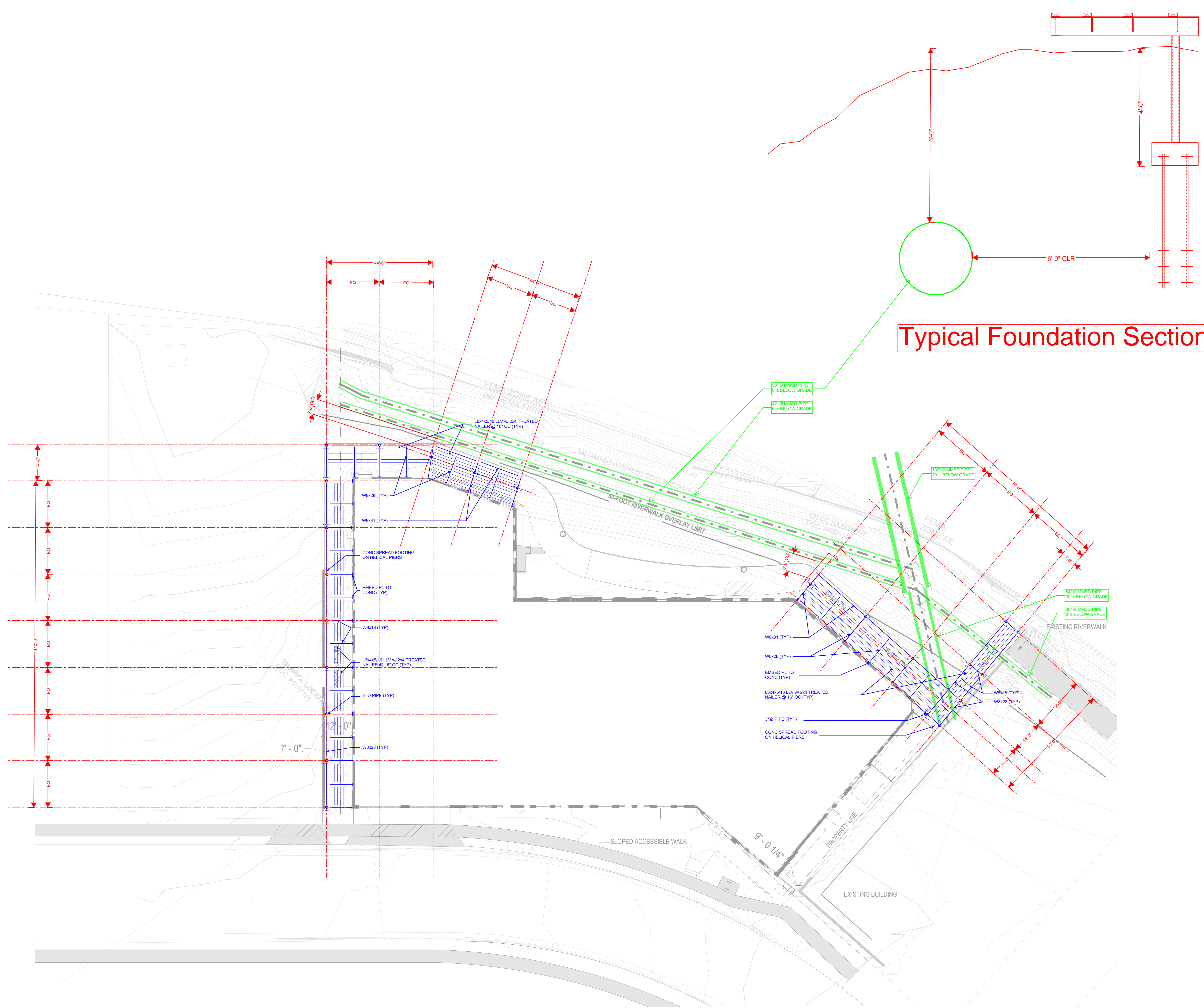

**Typical Foundation Section**

**Riverwalk Structural Framing Plan**  
Structural Members shown in blue

**1 RIVERWALK STRUCTURAL FRAMING PLAN**  
Scale: 1/16" = 1'-0"

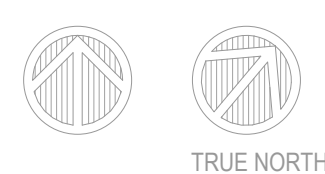

© COPYRIGHT 2020, CONTINUUM ARCHITECTS + PLANNERS, S.C.





T 414.220.9640  
 751 N Jefferson St.  
 Suite 200  
 Milwaukee, WI 53202

CONSULTANTS:

**NOT FOR CONSTRUCTION**  
 THESE DRAWINGS ARE RELEASED FOR DESIGN DEVELOPMENT PURPOSES ONLY. THEY ARE NOT TO BE USED FOR REGULATORY APPROVAL, PERMIT, OR CONSTRUCTION PURPOSES.

EIGHTEEN87 ON WATER  
 1887 N WATER STREET  
 MILWAUKEE, WI 53202

SHEET TITLE  
 SITE PLAN

REVISIONS:

SCALE	VARIES
PROJECT NUMBER	210502
SET TYPE	SPROZ SUBMITTAL
DATE ISSUED	07/20/2021
SHEET NUMBER	<b>A-201</b>



REFUSE COLLECTION AT THIS GARAGE ENTRY  
 GARBAGE CARTS LOCATED INTERNALLY

**WATER STREET**  
 (3) PROPOSED CALLERY PEAR  
 (4) BIKE PARKING  
 PROTECT EXISTING TREE  
 RECONNECT W/ EXISTING SIDEWALK

© COPYRIGHT 2020, CONTINUUM ARCHITECTS + PLANNERS, SC



**PERSPECTIVE VIEW 1**

**continum**  
ARCHITECTS + PLANNERS



**PERSPECTIVE VIEW 2**

**continum**  
ARCHITECTS + PLANNERS

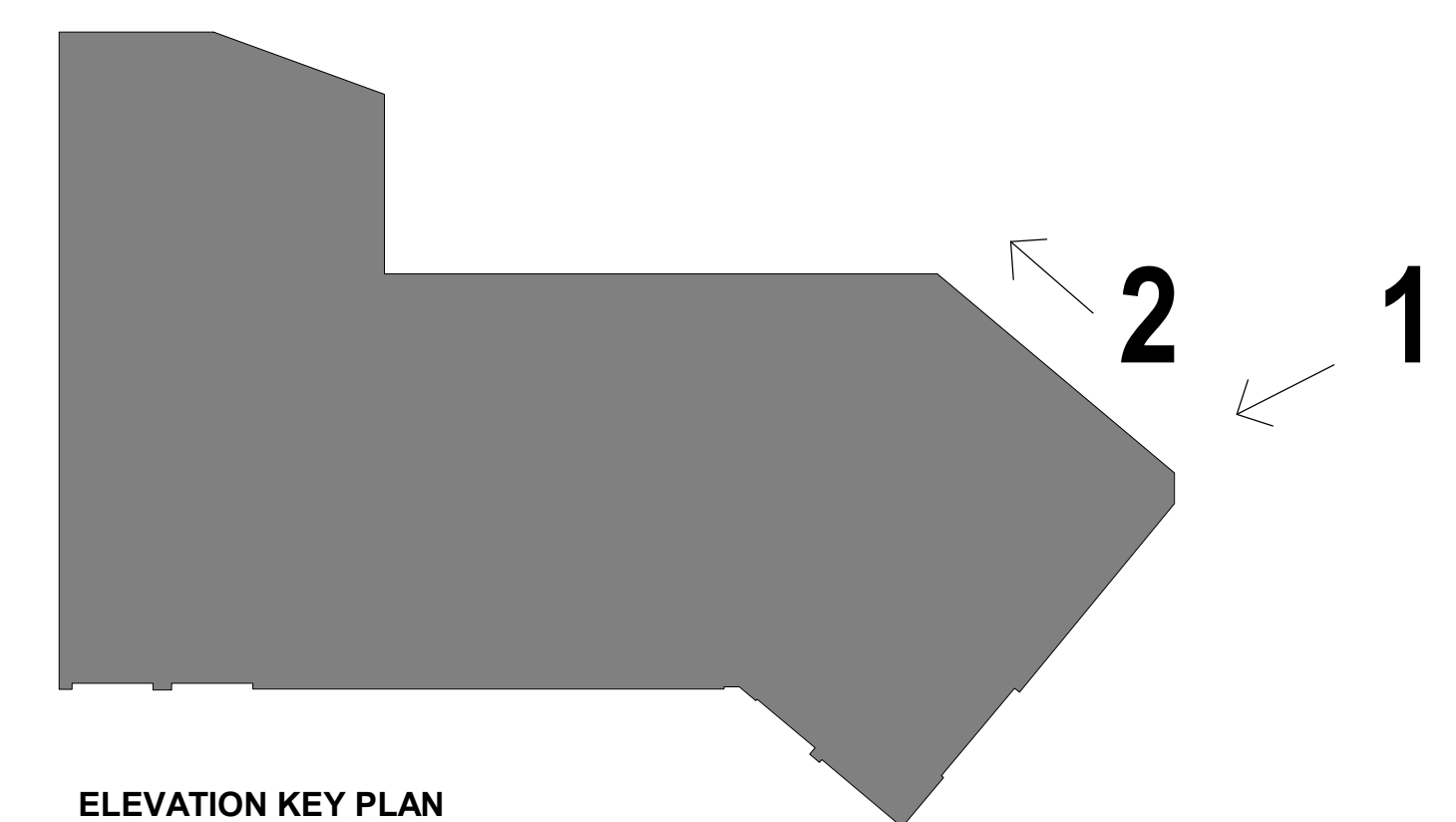

**ELEVATION KEY PLAN**  
SCALE: 1" = 40'-0"



T 414.220.9640  
751 N Jefferson St.  
Suite 200  
Milwaukee, WI 53202

CONSULTANTS:

**NOT FOR CONSTRUCTION**  
THESE DRAWINGS ARE RELEASED FOR DESIGN DEVELOPMENT PURPOSES ONLY. THEY ARE NOT TO BE USED FOR REGULATORY APPROVAL, PERMIT, OR CONSTRUCTION PURPOSES.

EIGHTEEN87 ON WATER

1887 N WATER STREET  
MILWAUKEE, WI 53202

SHEET TITLE:  
RIVERWALK PERSPECTIVES

REVISIONS:

SCALE	VARIES
PROJECT NUMBER	210502
SET TYPE	SPROZ SUBMITTAL
DATE ISSUED	07/20/2021
SHEET NUMBER	<b>A-202</b>



T 414.220.9640  
 751 N Jefferson St.  
 Suite 200  
 Milwaukee, WI 53202

CONSULTANTS:

**NOT FOR CONSTRUCTION**  
 THESE DRAWINGS ARE RELEASED FOR DESIGN DEVELOPMENT PURPOSES ONLY. THEY ARE NOT TO BE USED FOR REGULATORY APPROVAL, PERMIT, OR CONSTRUCTION PURPOSES.

EIGHTEEN87 ON WATER

1887 N WATER STREET  
 MILWAUKEE, WI 53202

SHEET TITLE:  
 RIVERWALK PERSPECTIVES

REVISIONS:

SCALE	VARIES
PROJECT NUMBER	210502
SET TYPE	SPROZ SUBMITTAL
DATE ISSUED	07/20/2021
SHEET NUMBER	<b>A-203</b>

© COPYRIGHT 2020, CONTINUUM ARCHITECTS + PLANNERS S.C.



**PERSPECTIVE VIEW 3**



**PERSPECTIVE VIEW 4**

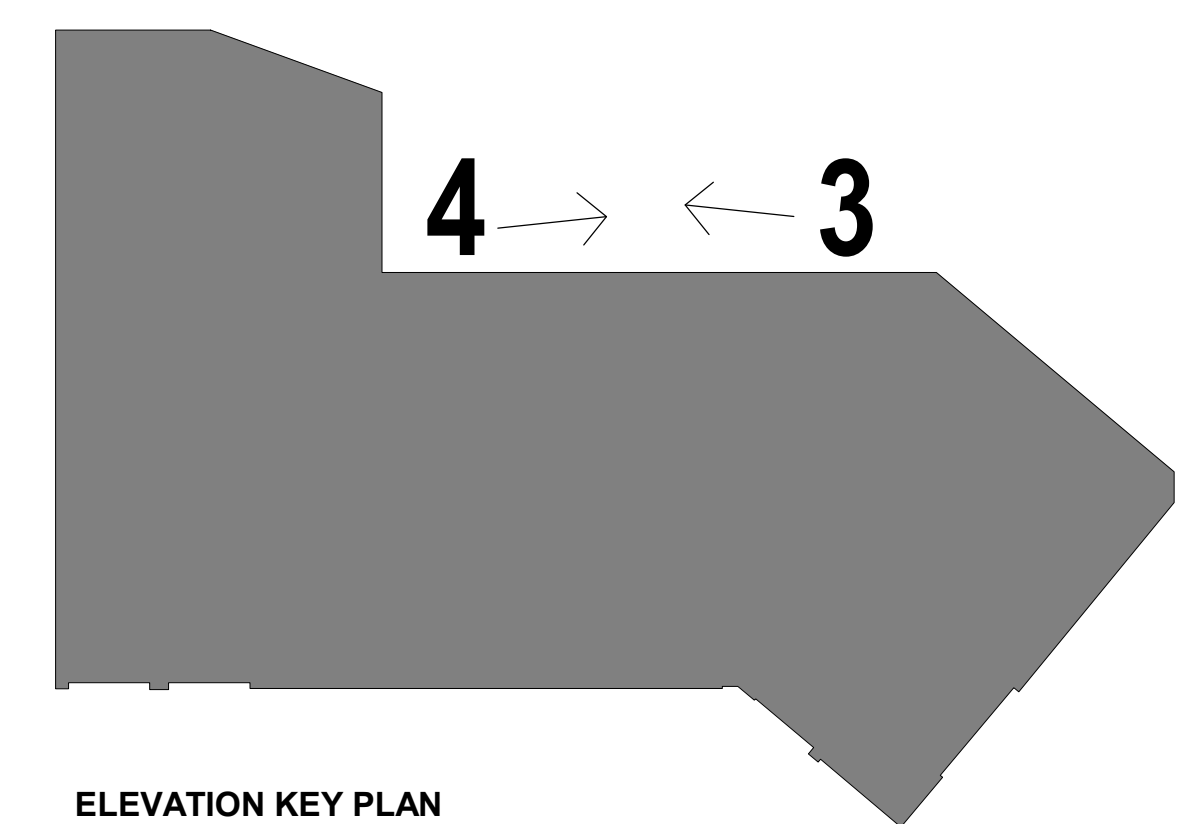

**ELEVATION KEY PLAN**  
 SCALES = 1/4"=1'-0"



**PERSPECTIVE VIEW 5**

**continem**  
ARCHITECTS + PLANNERS



**PERSPECTIVE VIEW 6**

**continem**  
ARCHITECTS + PLANNERS

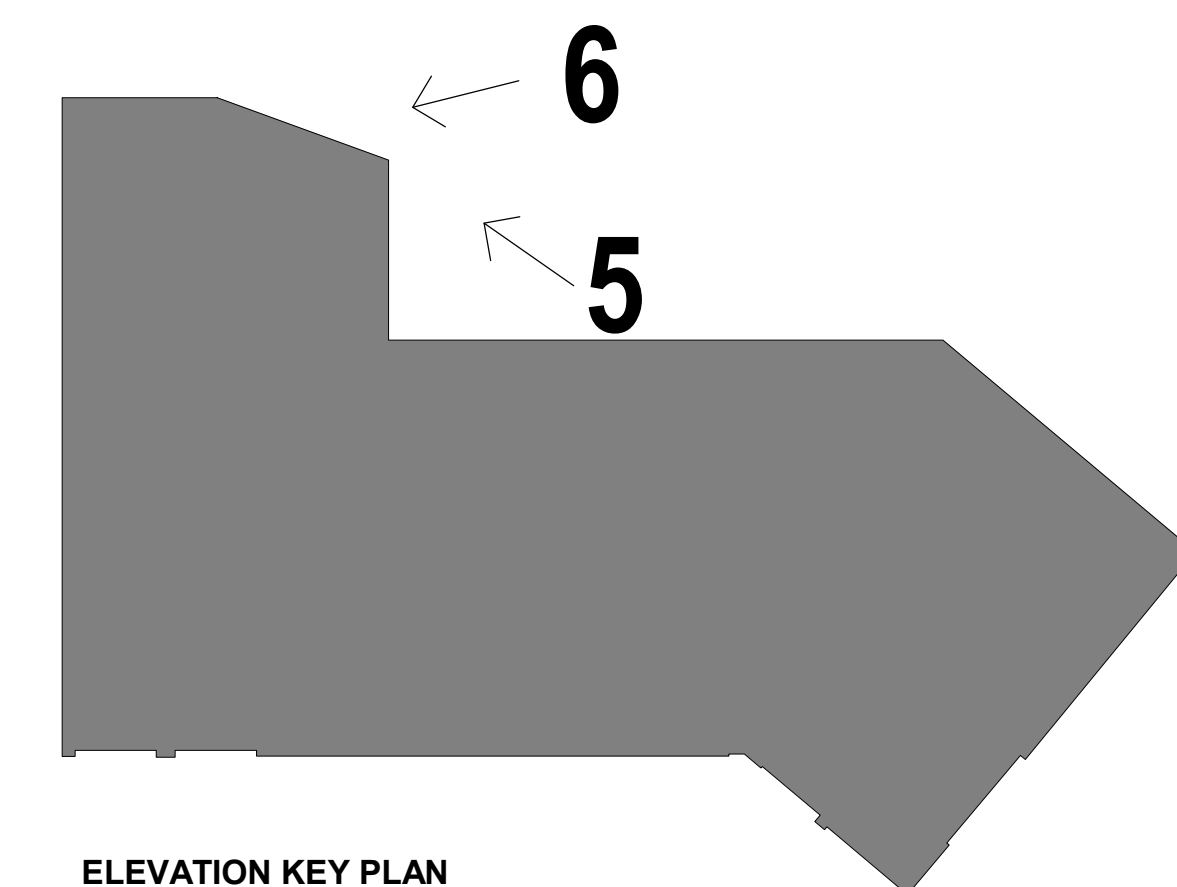

**ELEVATION KEY PLAN**  
SCALE 1" = 40'-0"



T 414.220.9640  
751 N Jefferson St.  
Suite 200  
Milwaukee, WI 53202

CONSULTANTS:

**NOT FOR CONSTRUCTION**  
THESE DRAWINGS ARE RELEASED FOR DESIGN DEVELOPMENT PURPOSES ONLY. THEY ARE NOT TO BE USED FOR REGULATORY APPROVAL, PERMIT, OR CONSTRUCTION PURPOSES.

EIGHTEEN87 ON WATER

1887 N WATER STREET  
MILWAUKEE, WI 53202

SHEET TITLE:  
RIVERWALK PERSPECTIVES

REVISIONS:

SCALE	VARIES
PROJECT NUMBER	210502
SET TYPE	SPOZ SUBMITTAL
DATE ISSUED	07/20/2021
SHEET NUMBER	<b>A-204</b>



**continum**  
ARCHITECTS + PLANNERS

**PERSPECTIVE VIEW 8**



**continum**  
ARCHITECTS + PLANNERS

**PERSPECTIVE VIEW 7**



**ELEVATION KEY PLAN**  
SCALE: 1" = 40'-0"



T 414.220.9640  
751 N Jefferson St.  
Suite 200  
Milwaukee, WI 53202

CONSULTANTS:

**NOT FOR CONSTRUCTION**  
THESE DRAWINGS ARE RELEASED FOR DESIGN DEVELOPMENT PURPOSES ONLY. THEY ARE NOT TO BE USED FOR REGULATORY APPROVAL, PERMIT, OR CONSTRUCTION PURPOSES.

EIGHTEEN87 ON WATER  
1887 N WATER STREET  
MILWAUKEE, WI 53202  
SHEET TITLE: RIVERWALK PERSPECTIVES

REVISIONS:

SCALE	VARIES
PROJECT NUMBER	210502
SET TYPE	SPROZ SUBMITTAL
DATE ISSUED	07/20/2021
SHEET NUMBER	<b>A-205</b>

© COPYRIGHT 2020, CONTINUUM ARCHITECTS + PLANNERS S.C.



T 414.220.9640  
751 N Jefferson St.  
Suite 200  
Milwaukee, WI 53202

CONSULTANTS:

© COPYRIGHT 2020, CONTINUUM ARCHITECTS + PLANNERS S.C.



4 BUILDING SECTION @ PARKING RAMP

Scale: 1/16" = 1'-0"



3 BUILDING SECTION @ ROOF TERRACE

Scale: 1/16" = 1'-0"

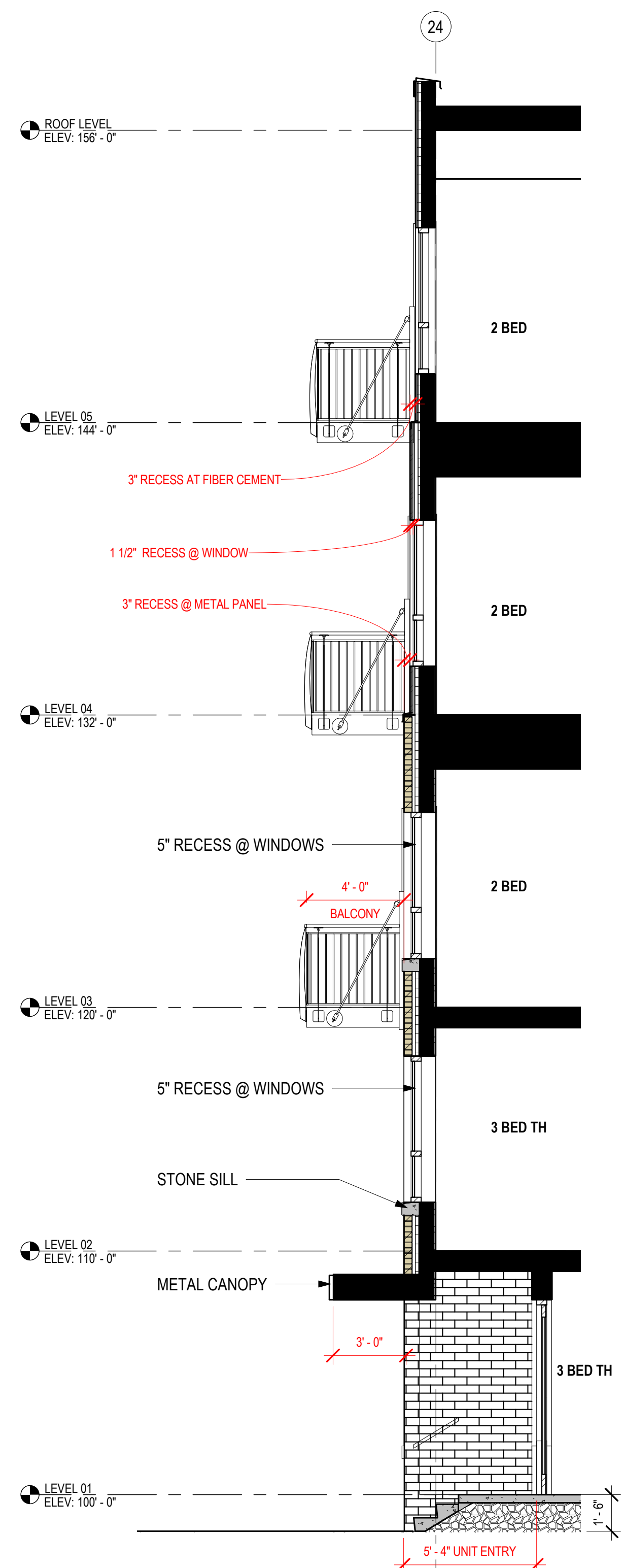

2 UNIT ENTRY SECTION

Scale: 1/4" = 1'-0"

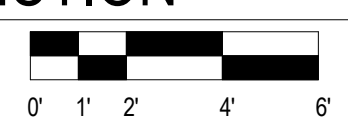

1 WEST ELEVATION

Scale: 1/8" = 1'-0"

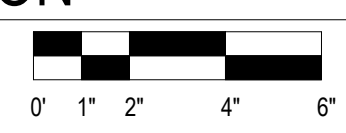

ELEVATION KEY PLAN

Scale: 1" = 60'-0"

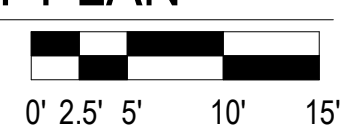

**NOT FOR CONSTRUCTION**  
THESE DRAWINGS ARE RELEASED FOR DESIGN DEVELOPMENT PURPOSES ONLY. THEY ARE NOT TO BE USED FOR REGULATORY APPROVAL, PERMIT, OR CONSTRUCTION PURPOSES.

EIGHTEEN87 ON WATER  
1887 N WATER STREET  
MILWAUKEE, WI 53202  
SHEET TITLE: WEST ELEVATION & BUILDING SECTIONS

REVISIONS:

SCALE	VARIES
PROJECT NUMBER	210502
SET TYPE	SPROZ SUBMITTAL
DATE ISSUED	07/20/2021
SHEET NUMBER	<b>A400</b>



T 414.220.9640  
751 N Jefferson St.  
Suite 200  
Milwaukee, WI 53202

CONSULTANTS:

**NOT FOR CONSTRUCTION**  
THESE DRAWINGS ARE RELEASED FOR DESIGN DEVELOPMENT PURPOSES ONLY. THEY ARE NOT TO BE USED FOR REGULATORY APPROVAL, PERMIT, OR CONSTRUCTION PURPOSES.

EIGHTEEN87 ON WATER  
1887 N WATER STREET  
MILWAUKEE, WI 53202  
SHEET TITLE  
NORTH & EAST ELEVATIONS

REVISIONS:

SCALE	VARIES
PROJECT NUMBER	210502
SET TYPE	SPROZ SUBMITTAL
DATE ISSUED	07/20/2021
SHEET NUMBER	<b>A401</b>



**4 NORTH ELEVATION**  
Scale: 1/8" = 1'-0"

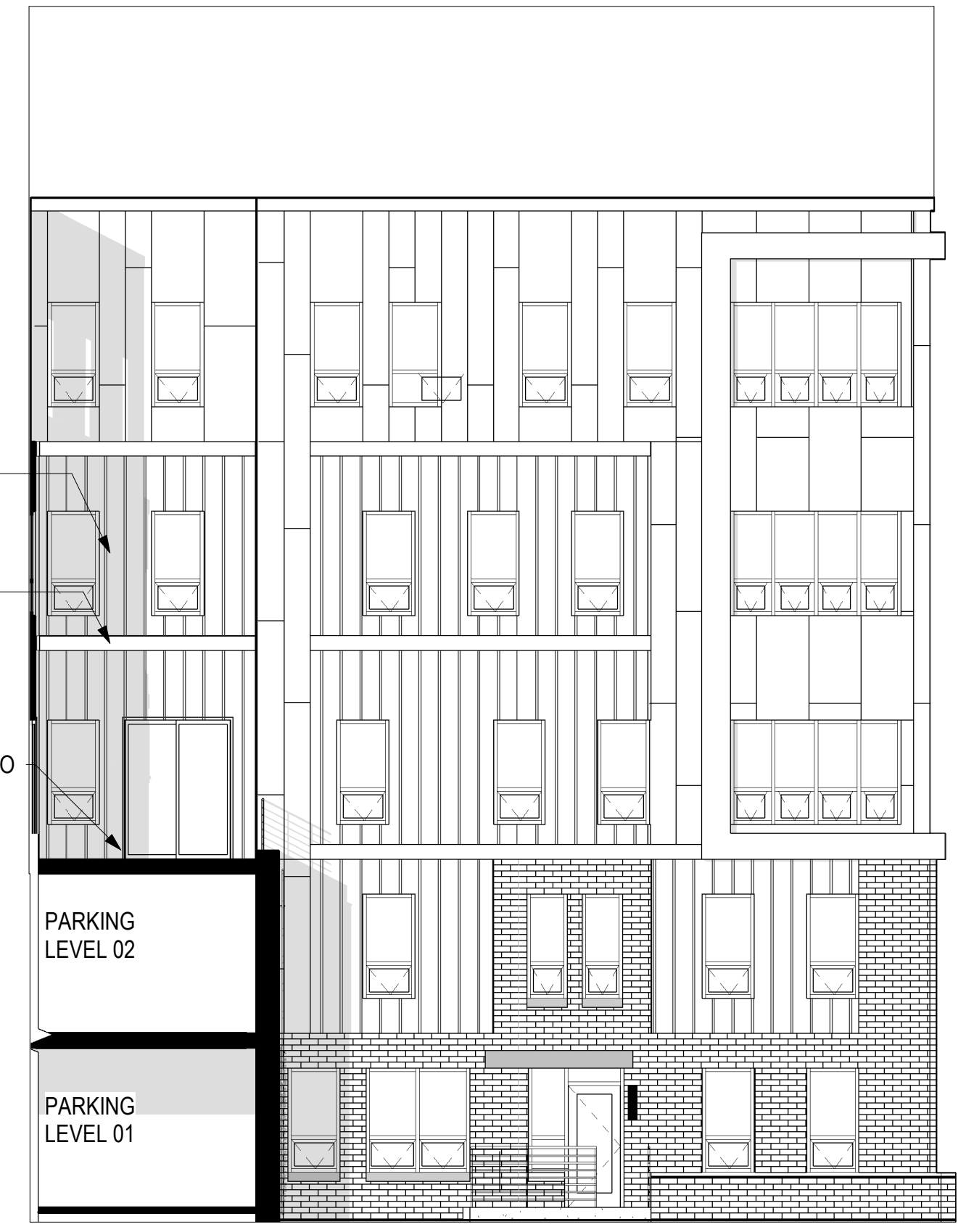
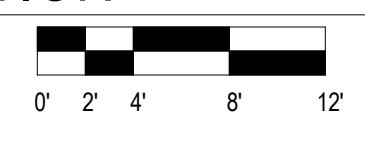

**3 EAST ELEVATION - NORTH WING**  
Scale: 1/8" = 1'-0"

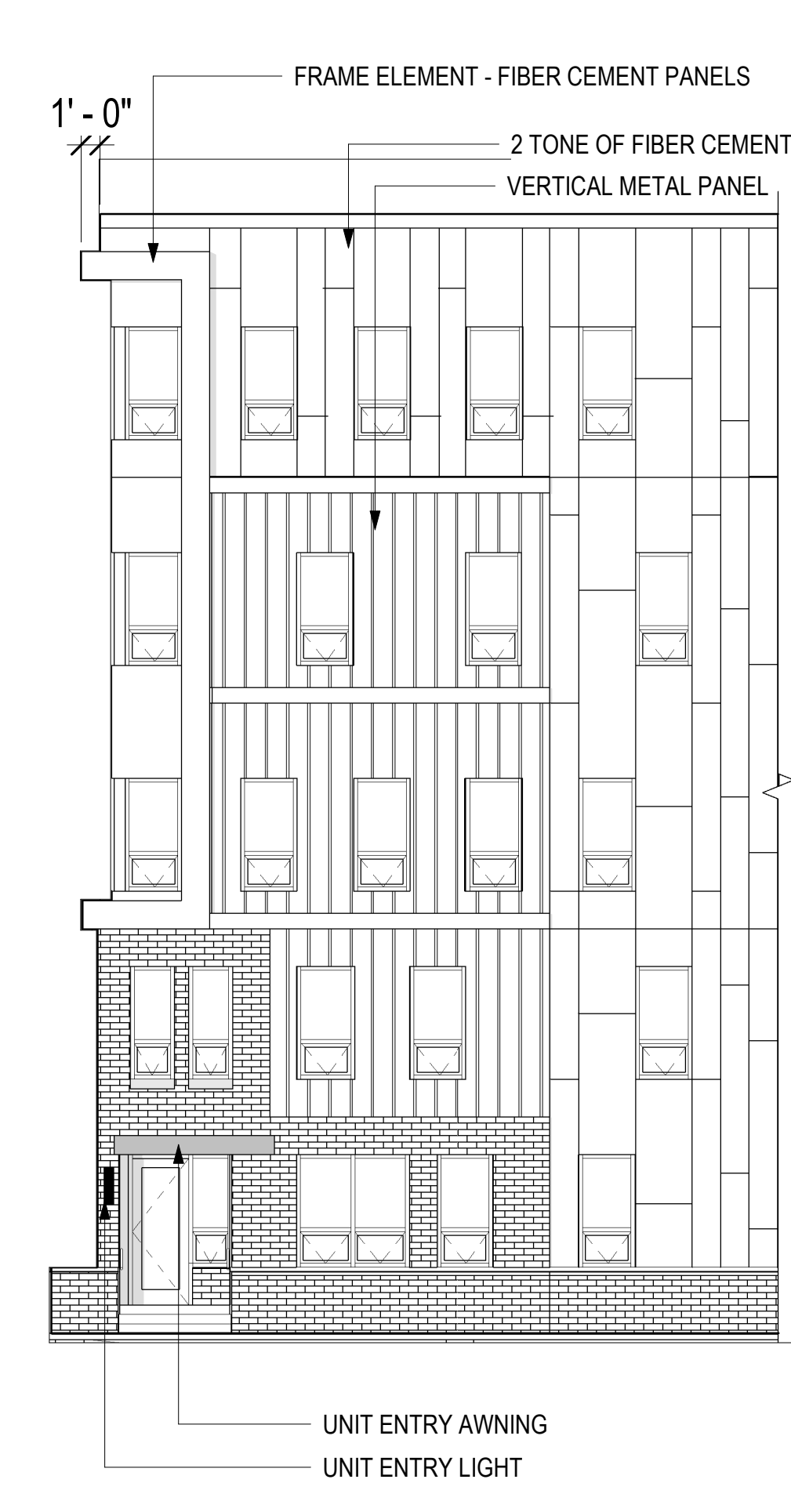
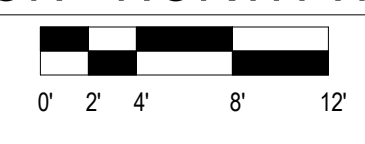

**2 NORTH WING ANGLED WALL**  
Scale: 1/8" = 1'-0"

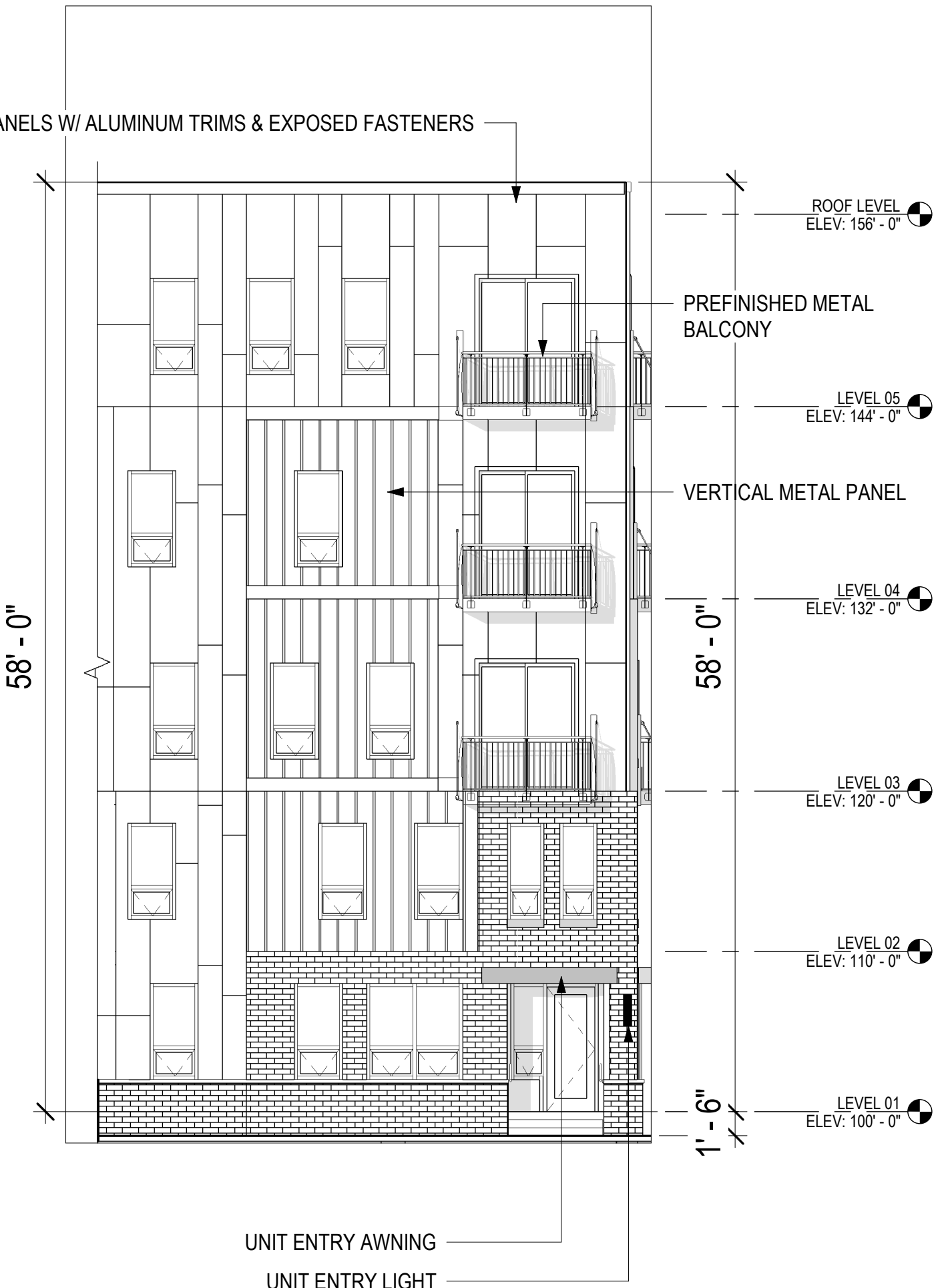
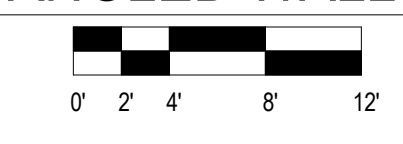

**1 NORTH WING ELEVATION**  
Scale: 1/8" = 1'-0"

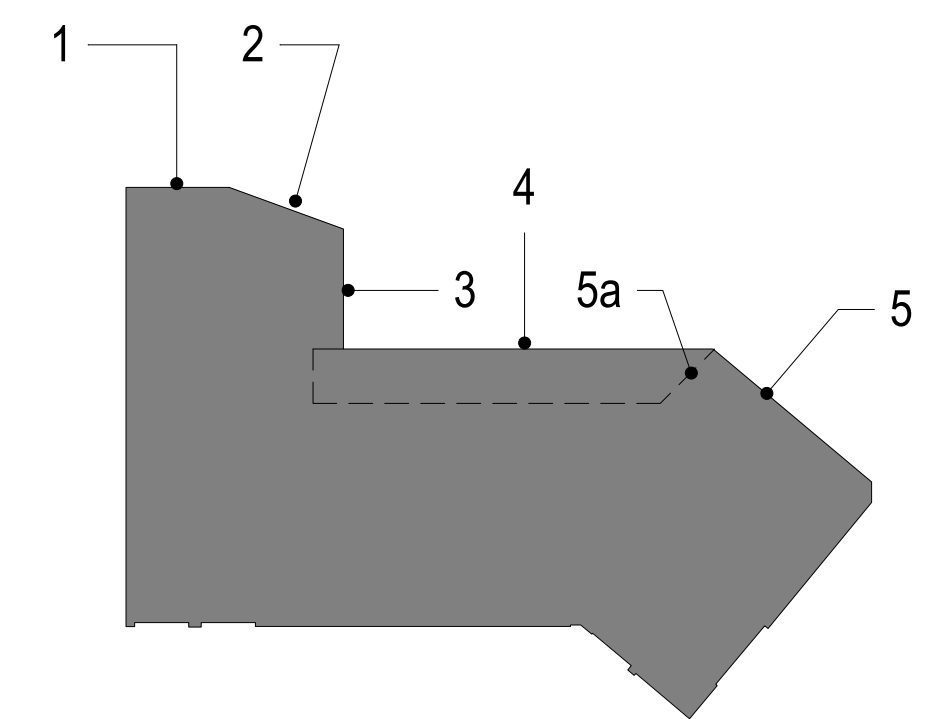

**ELEVATION KEY PLAN**  
Scale: 1" = 60'-0"

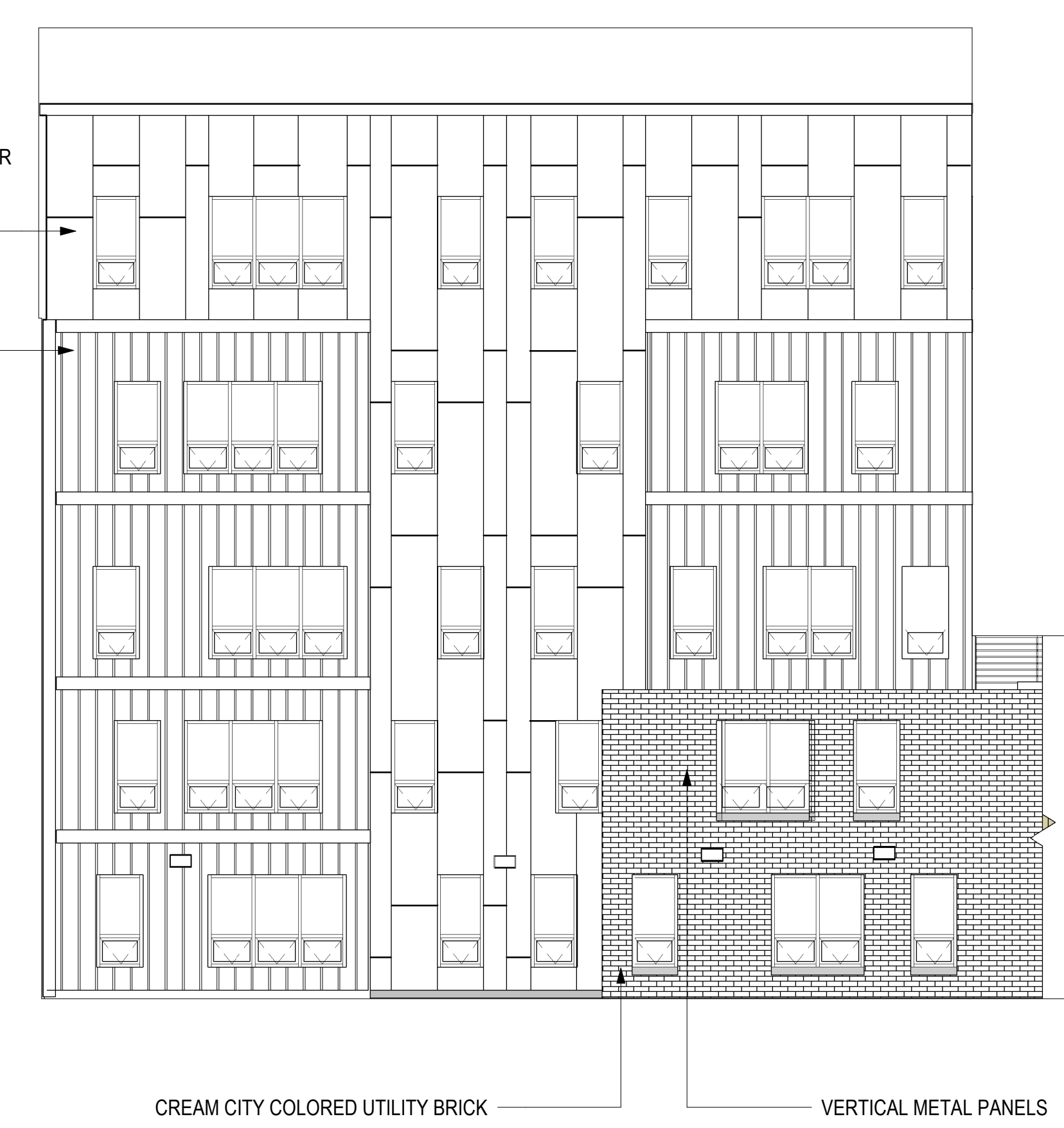
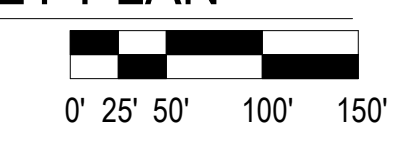

**5 NORTH ELEVATION ANGLED WALL**  
Scale: 1/8" = 1'-0"

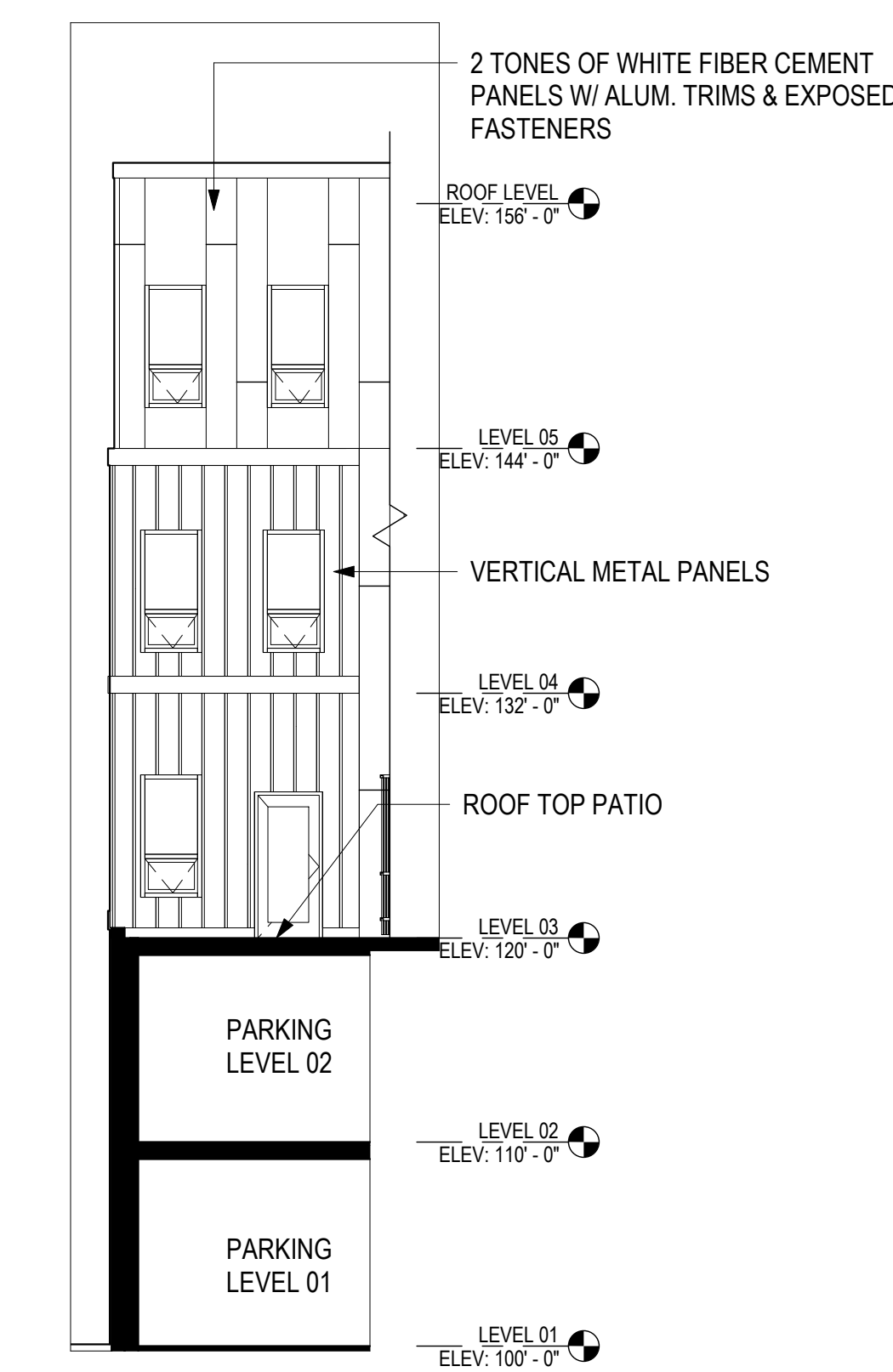

**5a NORTH ELEVATION - ANGLED WALL**  
Scale: 1/8" = 1'-0"





# PERSPECTIVE VIEW - WEST ELEVATION

**continem**  
ARCHITECTS + PLANNERS



ELEVATION KEY PLAN  
SCALE 1" = 60'-0"



T 414.220.9640  
751 N Jefferson St.  
Suite 200  
Milwaukee, WI 53202

CONSULTANTS:

**NOT FOR CONSTRUCTION**  
THESE DRAWINGS ARE RELEASED FOR DESIGN DEVELOPMENT PURPOSES ONLY. THEY ARE NOT TO BE USED FOR REGULATORY APPROVAL, PERMIT, OR CONSTRUCTION PURPOSES.

EIGHTEEN87 ON WATER  
1887 N WATER STREET  
MILWAUKEE, WI 53202  
SHEET TITLE:  
WEST BUILDING PERSPECTIVE

REVISIONS:

SCALE	VARIES
PROJECT NUMBER	210502
SET TYPE	SPROZ SUBMITTAL
DATE ISSUED	07/20/2021
SHEET NUMBER	<b>A502</b>





# PERSPECTIVE VIEW - NORTH ELEVATION

**continem**  
ARCHITECTS + PLANNERS



ELEVATION KEY PLAN  
SCALE 1" = 60'-0"



T 414.220.9640  
751 N Jefferson St.  
Suite 200  
Milwaukee, WI 53202

CONSULTANTS:

**NOT FOR CONSTRUCTION**  
THESE DRAWINGS ARE RELEASED FOR DESIGN DEVELOPMENT PURPOSES ONLY. THEY ARE NOT TO BE USED FOR REGULATORY APPROVAL, PERMIT, OR CONSTRUCTION PURPOSES.

EIGHTEEN87 ON WATER

1887 N WATER STREET  
MILWAUKEE, WI 53202

SHEET TITLE  
NORTH BUILDING PERSPECTIVE

REVISIONS:

SCALE	VARIABLE
PROJECT NUMBER	210502
SET TYPE	SPROZ SUBMITTAL
DATE ISSUED	07/20/2021
SHEET NUMBER	<b>A503</b>



**continym**  
ARCHITECTS + PLANNERS



**continym**  
ARCHITECTS + PLANNERS

# PERSPECTIVE VIEWS - EAST VIEW

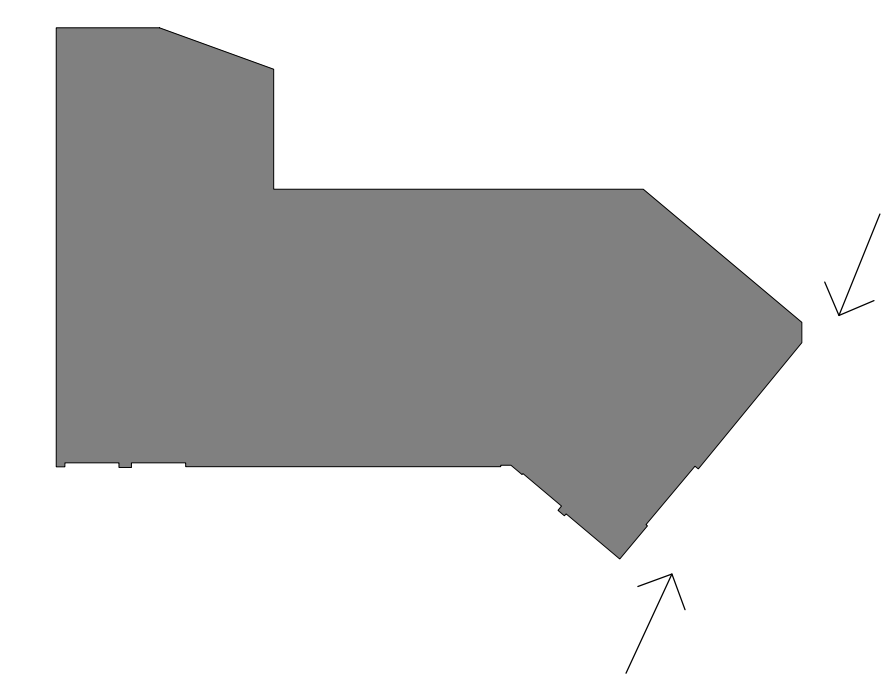

ELEVATION KEY PLAN  
SCALE 1" = 60'-0"



T 414.220.9640  
751 N Jefferson St.  
Suite 200  
Milwaukee, WI 53202

CONSULTANTS:

**NOT FOR CONSTRUCTION**  
THESE DRAWINGS ARE RELEASED FOR DESIGN DEVELOPMENT PURPOSES ONLY. THEY ARE NOT TO BE USED FOR REGULATORY APPROVAL, PERMIT, OR CONSTRUCTION PURPOSES.

EIGHTEEN87 ON WATER  
1887 N WATER STREET  
MILWAUKEE, WI 53202  
SHEET TITLE  
EAST BUILDING PERSPECTIVES

REVISIONS:

SCALE	VARIES
PROJECT NUMBER	210502
SET TYPE	SPROZ SUBMITTAL
DATE ISSUED	07/20/2021
SHEET NUMBER	<b>A504</b>