

UIHLEIN | WILSON
RAMLOW | STEIN
ARCHITECTURE | DESIGN | PLANNING

322 East Michigan Street
Milwaukee, WI 53202
telephone | 414.271.8899
email | office@uihleין-wilson.com

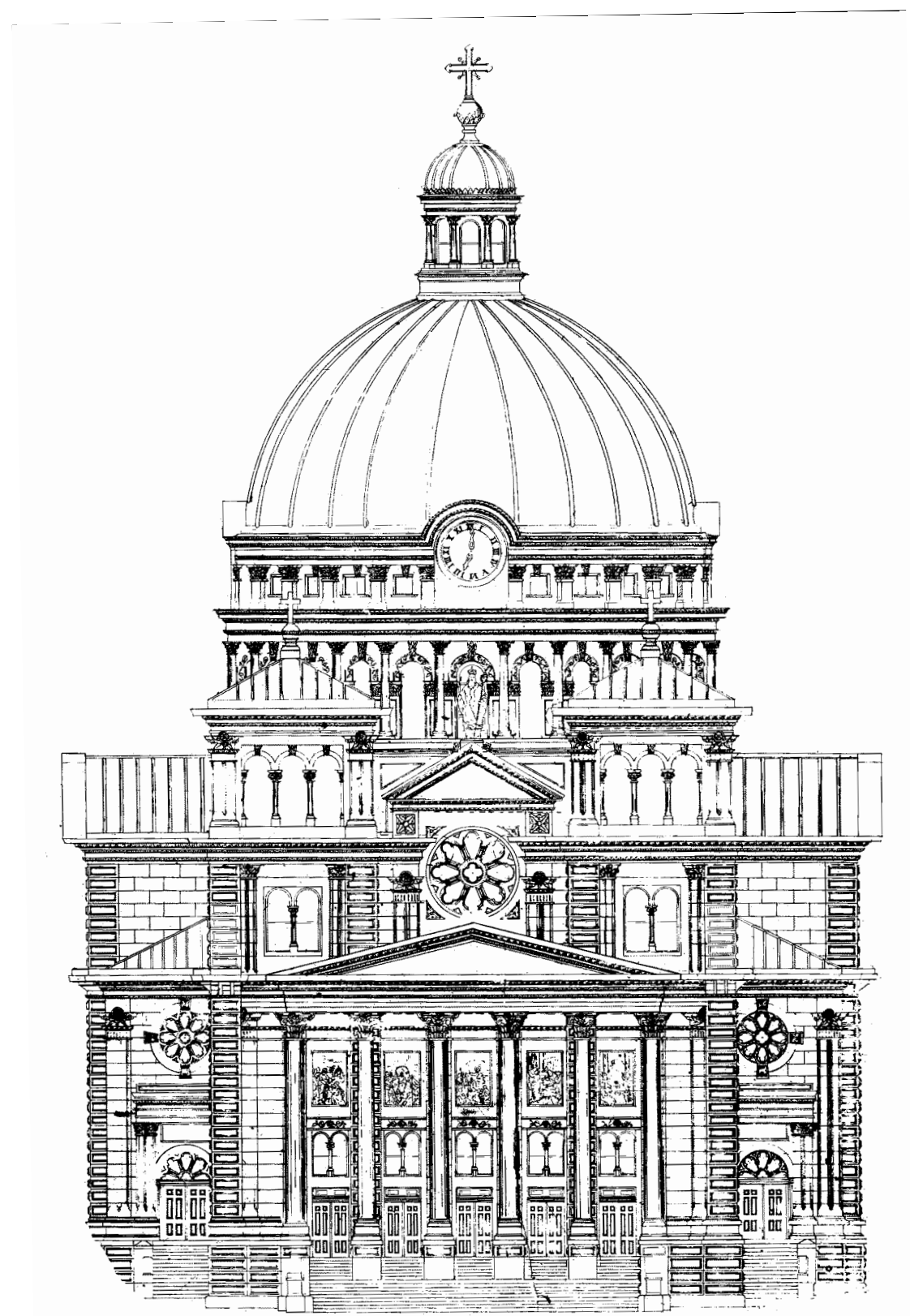

© UIHLEIN WILSON ARCHITECTS, INC. ALL RIGHTS RESERVED

OWNERSHIP OF DOCUMENTS
This document, and the ideas and designs incorporated herein, are the property of Uihlein Wilson Architects, Inc. and it is not to be used in whole or in part for any other project or purpose without the expressed written authorization of Uihlein Wilson Architects, Inc.

REVISIONS		
No.	Date	Description

BASILICA OF ST. JOSAPHAT EXTERIOR REPAIR

7/16/18 BID DOCUMENTS

18-120

St. Josaphat Basilica Foundation
2333 S. 6th Street
Milwaukee, WI 53215

INDEX		
Sheet Number	Sheet Name	Drawn By
GENERAL		
G1	TITLE SHEET & INDEX	UWA
ARCHITECTURAL		
A1	KEY PLAN	UWA
A2	KEY ELEVATIONS	Author
A3	KEY PLAN - WINDOW REPAIR	Author
A4	ARCHITECTURAL DETAILS	Author
STRUCTURAL		
S1	NORTH ELEVATION	PE
S2	EAST ELEVATION	PE
S3	SOUTH ELEVATION	PE
S4	WEST ELEVATION	PE
S5	DETAILS	PE

OWNER:
FRANCISCAN FATHERS MINOR CONVENTUAL
OF ST. JOSAPHAT CHURCH IN MILWAUKEE,
WISCONSIN
2333 S. 6TH STREET
MILWAUKEE, WI 53215

ST. JOSAPHAT BASILICA FOUNDATION, INC.
620 W. LINCOLN AVENUE
MILWAUKEE, WI 53215

ARCHITECT:
UIHLEIN/WILSON ARCHITECTS, INC.
322 E. MICHIGAN STREET, SUITE 400
MILWAUKEE, WI 53202
414-271-8899

STRUCTURAL ENGINEER:
PIERCE ENGINEERS, INC.
241 N. BROADWAY AVE, SUITE 500
MILWAUKEE, WI 53202
414-278-6020

PROJECT

BASILICA OF
ST.
JOSAPHAT
EXTERIOR
REPAIR

St. Josaphat Basilica Foundation

SHEET

TITLE SHEET &
INDEX

DATE

7/16/18

PROJECT NO.

18-120

SHEET NO.

G1

LINCOLN AVE.



UIHLEIN | WILSON
RAMLOW | STEIN
ARCHITECTURE | DESIGN | PLANNING

322 East Michigan Street
Milwaukee, WI 53202
telephone | 414.271.8899
email | office@uihlein-wilson.com

© UIHLEIN WILSON ARCHITECTS, INC. ALL RIGHTS RESERVED

OWNERSHIP OF DOCUMENTS
This document, and the ideas and designs incorporated herein, are the property of Uihlein Wilson Architects, Inc. and it is not to be used in whole or in part for any other project or purpose without the expressed written authorization of Uihlein Wilson Architects, Inc.

REVISIONS		
No.	Date	Description

PROJECT

BASILICA OF ST. JOSAPHAT EXTERIOR REPAIR

St. Josaphat Basilica Foundation

SHEET

KEY PLAN

DATE

7/16/18

PROJECT NO.

18-120

SHEET NO.

A1

6TH STREET

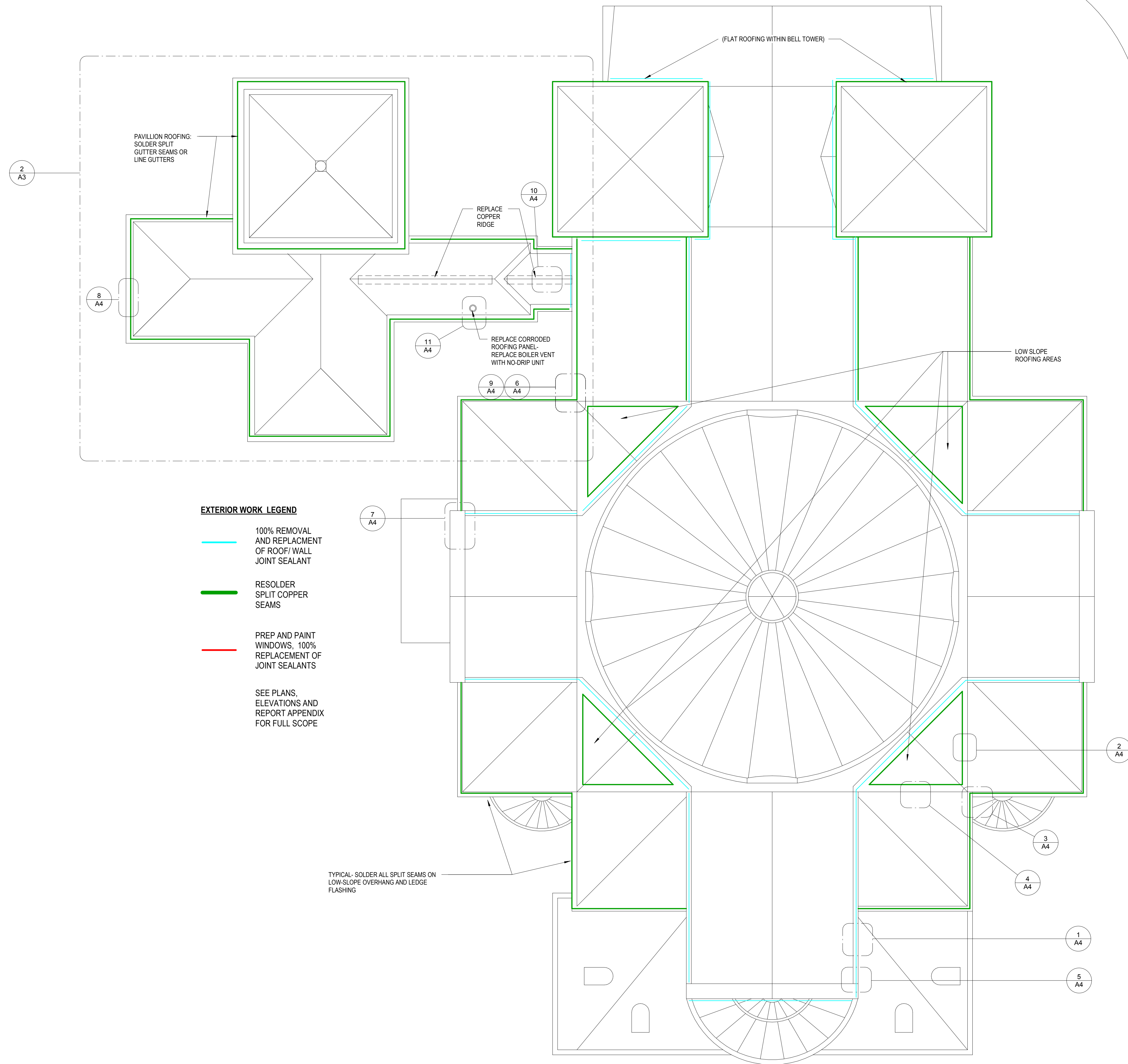

- EXTERIOR WORK LEGEND**
- 100% REMOVAL AND REPLACEMENT OF ROOF/ WALL JOINT SEALANT
 - RESOLDER SPLIT COPPER SEAMS
 - PREP AND PAINT WINDOWS, 100% REPLACEMENT OF JOINT SEALANTS
- SEE PLANS, ELEVATIONS AND REPORT APPENDIX FOR FULL SCOPE





UIHLEIN | WILSON
RAMLOW | STEIN
ARCHITECTURE | DESIGN | PLANNING

322 East Michigan Street
Milwaukee, WI 53202
telephone | 414.271.8899
email | office@uihlein-wilson.com

© UIHLEIN WILSON ARCHITECTS, INC. ALL RIGHTS RESERVED

OWNERSHIP OF DOCUMENTS
This document, and the ideas and designs incorporated herein, are an instrument of professional service, in the sole property of Uihlein Wilson Architects, Inc., and it is not to be used in whole or in part for any other project or purpose without the expressed written authorization of Uihlein Wilson Architects, Inc.

REVISIONS		
No.	Date	Description

PROJECT

BASILICA OF ST. JOSAPHAT EXTERIOR REPAIR

St. Josaphat Basilica Foundation

SHEET

KEY ELEVATIONS

DATE
7/16/18

PROJECT NO.
18-120

SHEET NO.

A2

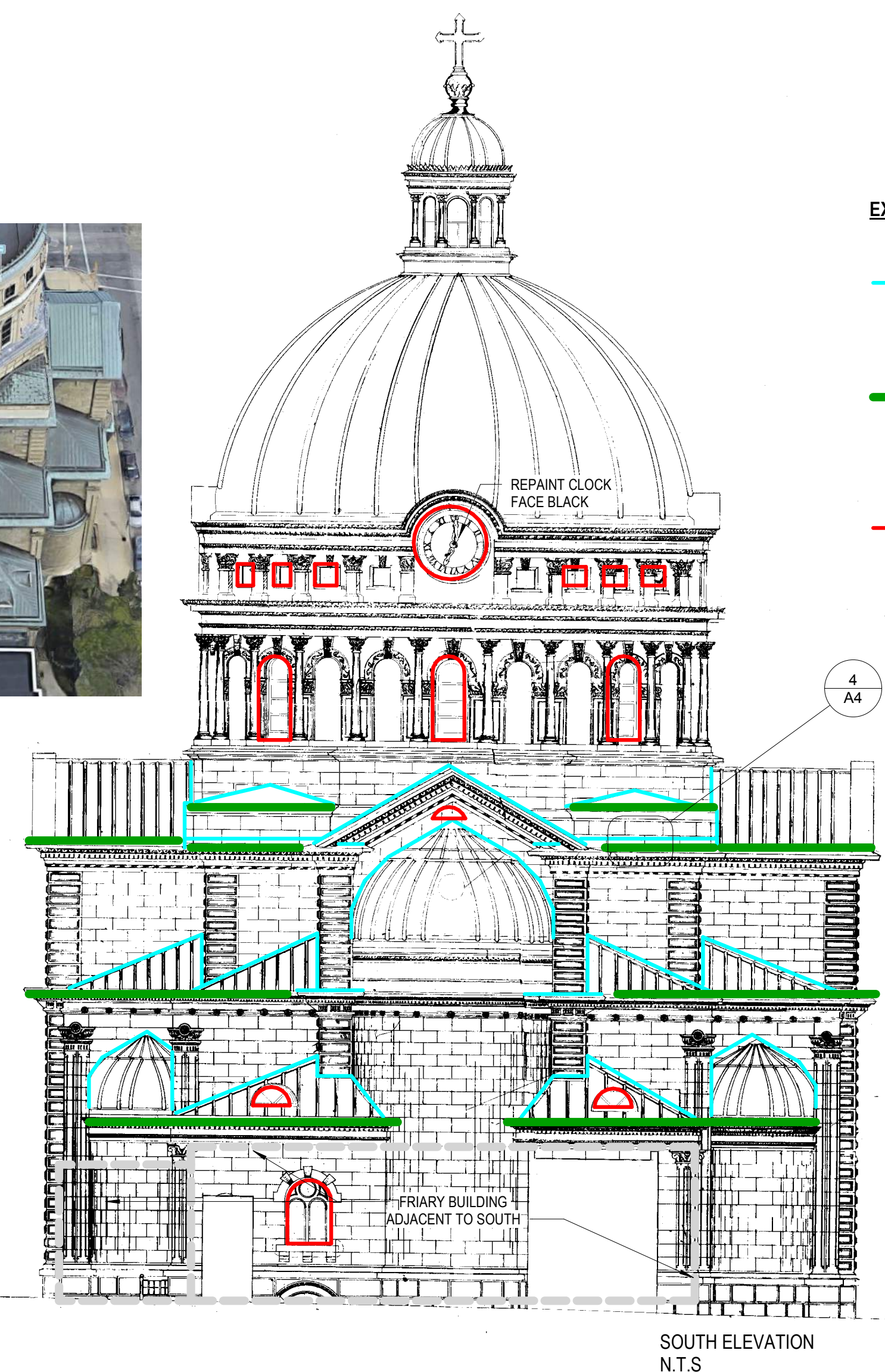
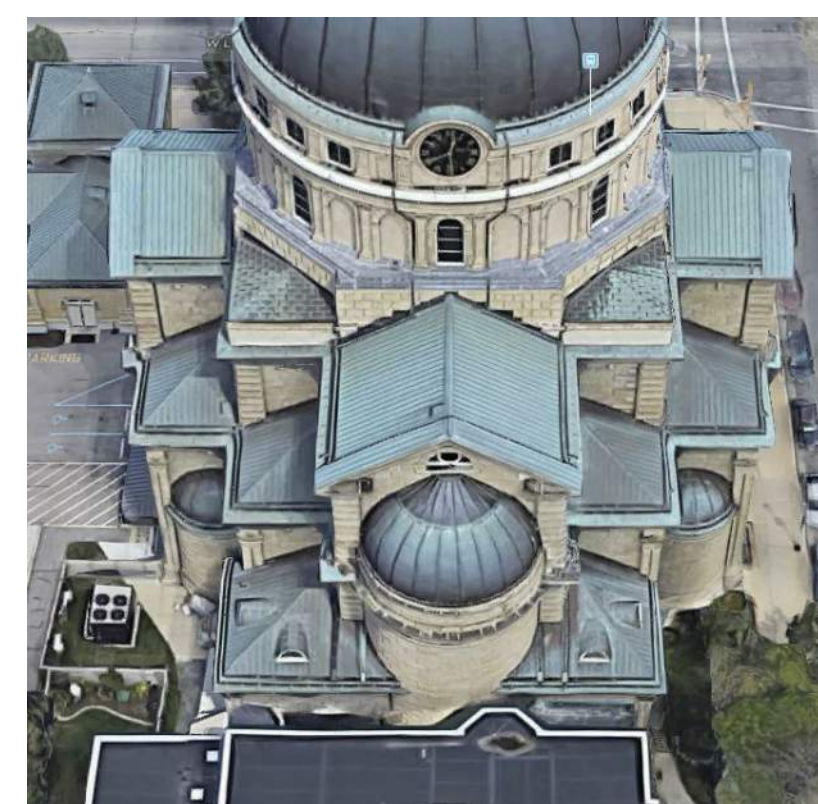

EXTERIOR WORK LEGEND

— 100% REMOVAL AND REPLACEMENT OF ROOF/WALL JOINT SEALANT

— RESOLDER SPLIT COPPER SEAMS

— PREP AND PAINT WINDOWS, 100% REPLACEMENT OF JOINT SEALANTS

SEE PLANS, ELEVATIONS AND REPORT APPENDIX FOR FULL SCOPE

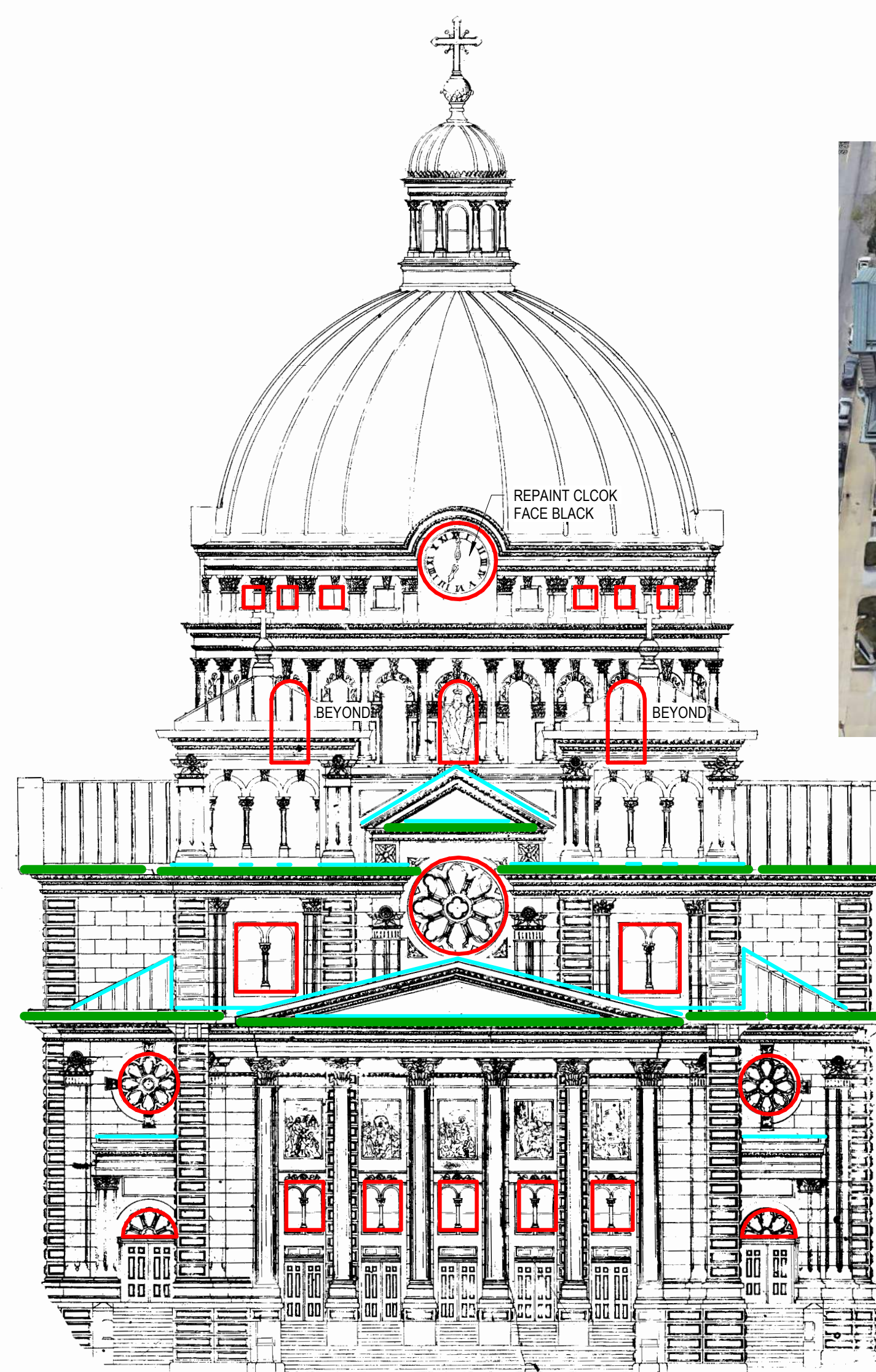
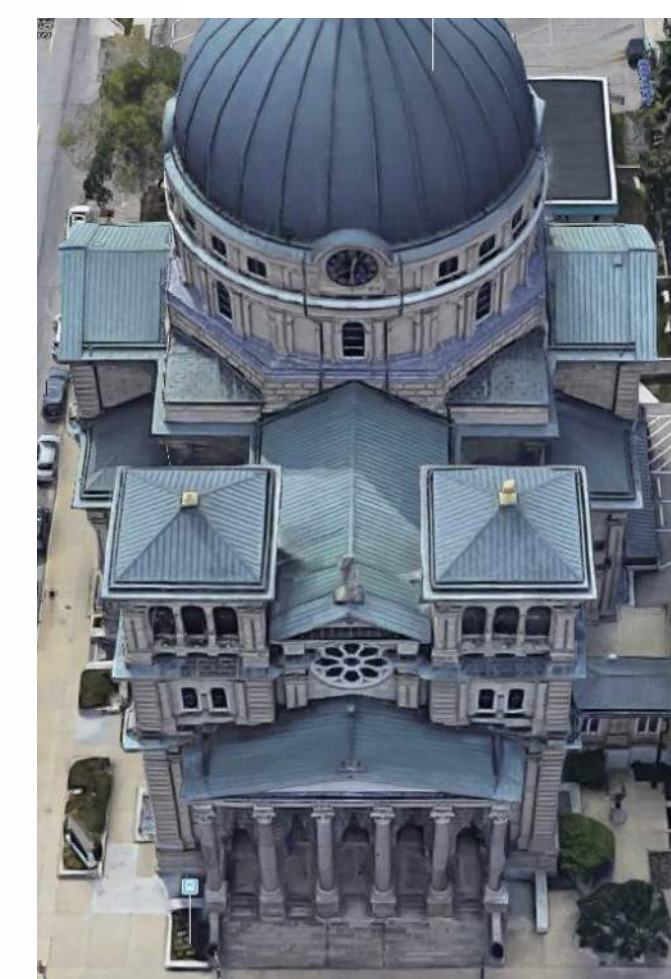

NORTH ELEVATION
N.T.S.

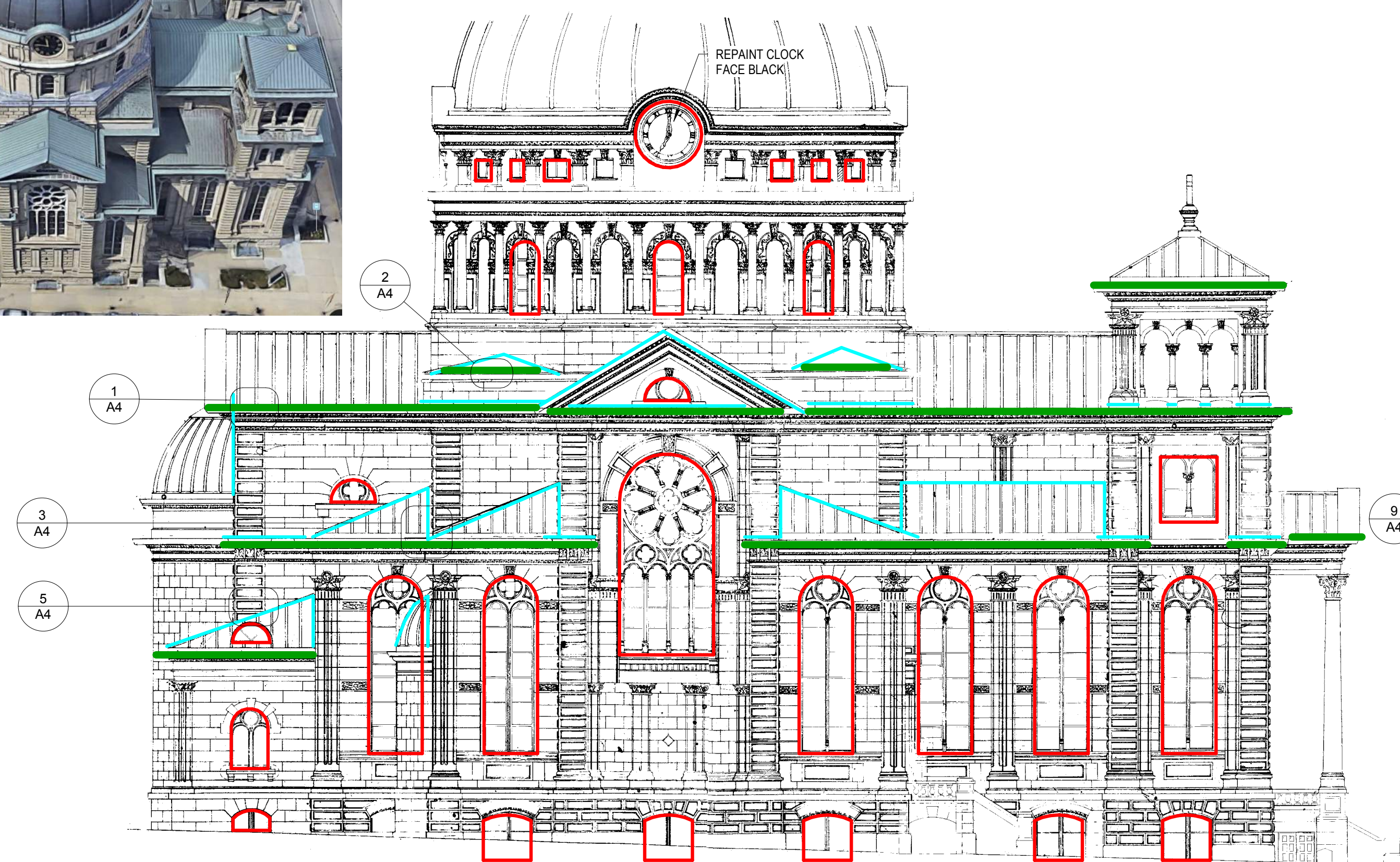

EAST ELEVATION
N.T.S.

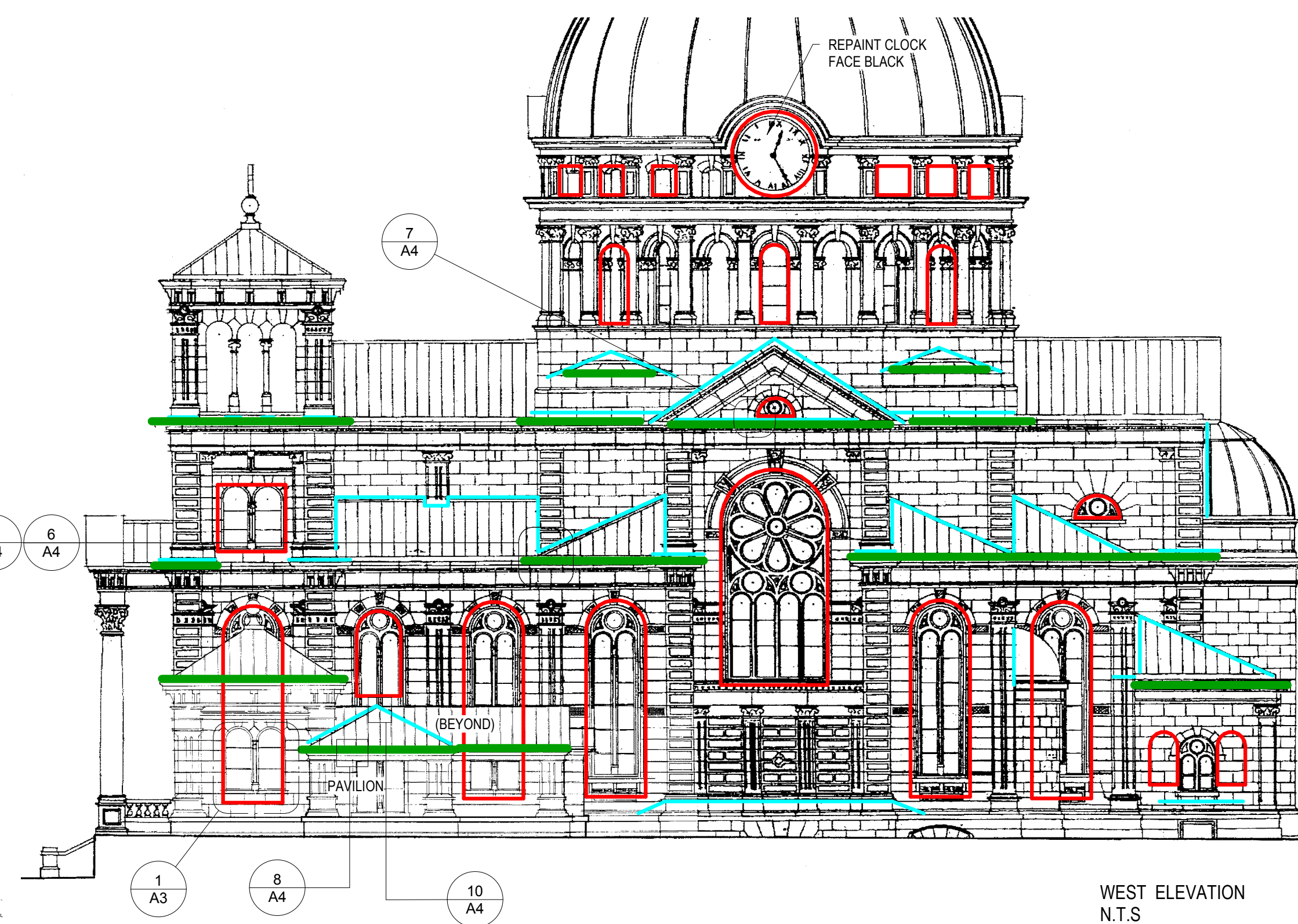

WEST ELEVATION
N.T.S.



UIHLEIN | WILSON
RAMLOW | STEIN
ARCHITECTURE | DESIGN | PLANNING

322 East Michigan Street
Milwaukee, WI 53202
telephone | 414.271.8899
email | office@uihlein-wilson.com

© UIHLEIN WILSON ARCHITECTS, INC. ALL RIGHTS RESERVED

OWNERSHIP OF DOCUMENTS
This document, and the ideas and designs incorporated herein, are an instrument of professional service, and are the sole property of Uihlein Wilson Architects, Inc. and it is not to be used in whole or in part for any other project or purpose without the expressed written authorization of Uihlein Wilson Architects, Inc.

REVISIONS		
No.	Date	Description

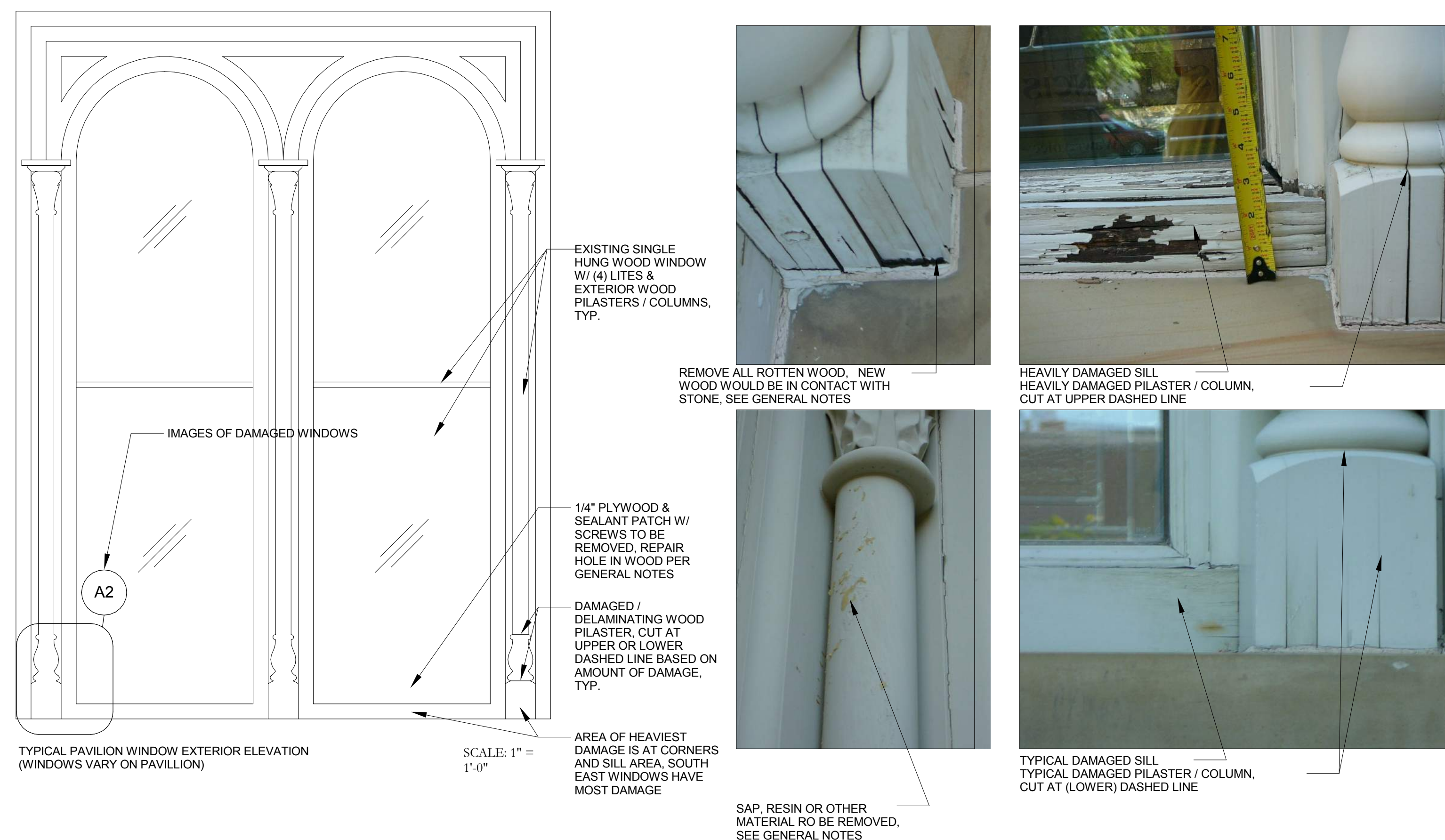

1 PAVILION WINDOW ELEVATION & IMAGES
1" = 1'-0"

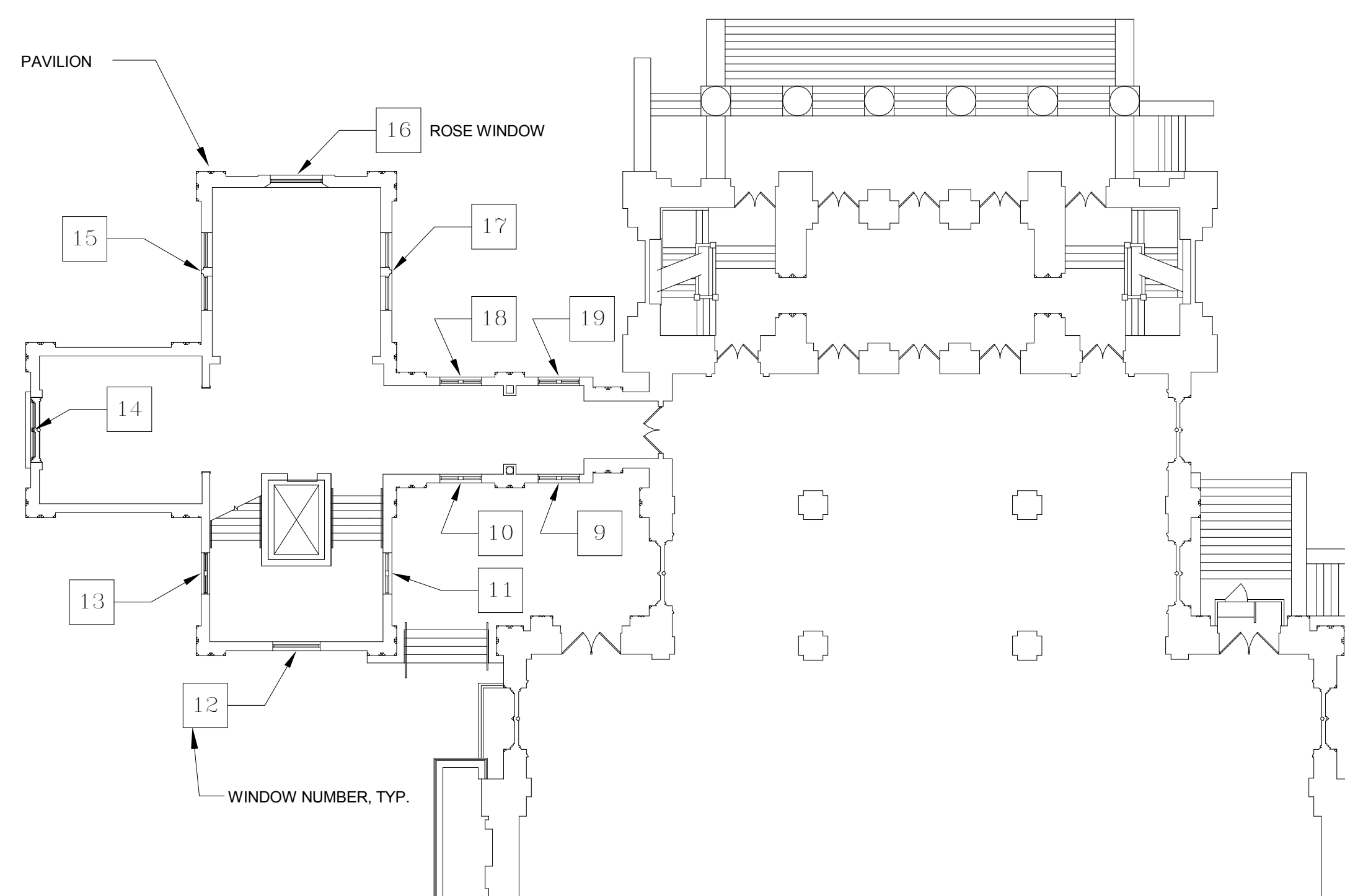

2 WINDOW REPAIRS KEY
1/16" = 1'-0"

- GENERAL NOTES (PAVILION WINDOWS):
- 1) GLASS IS TO BE PROTECTED AND REUSED, REMOVE & RESET AS REQUIRED; ALL STAINED GLASS IS TO BE PROTECTED OR REMOVED AND REINSTALLED IF REQUIRED
 - 2) REMOVE ALL EXTERIOR SEALANT AT WINDOWS & REMOVE ALL DAMAGED / DEGRADED SEALANT SURROUNDING WINDOWS. SPECIAL CARE IS TO BE TAKEN NOT TO DAMAGE STONE OR WOOD TO REMAIN DURING SEALANT REMOVAL
 - 3) REMOVE ALL EXTERIOR PAINT ON WINDOWS IN AFFECTED AREAS BY SCRAPING, CHEMICALS ARE NOT ALLOWED UNLESS INFORMED OTHERWISE
 - 4) CONSOLIDATE WOOD THAT IS LIGHTLY DAMAGED, TO BE APPROVED BY ARCHITECT
 - 5) REMOVE ALL ROTTEN, DELAMINATING OR DAMAGED WOOD AND REPLACE W/ NEW HARDWOOD TO EXACTLY MATCH EXISTING PROFILES. FOR HORIZONTAL MEMBERS THAT WERE AT THE BOTTOM OF THE WINDOWS COMPOSITE OR PVC IS TO BE USED AS THE REPLACEMENT MATERIAL WHERE FEASIBLE FOR INCREASED WATER RESISTANCE. EXISTING PROFILES ARE STILL REQUIRED TO BE EXACTLY MATCHED
 - 6) REMOVE LOWER PORTION OF DAMAGED / DELAMINATING WOOD PILASTERS / WOOD COLUMNS & REPLACE W/ NEW HARDWOOD TO EXACTLY MATCH EXISTING PROFILES
 - 7) WOOD WITH SAP, RESIN OR OTHER MATERIAL SEEPING THROUGH THE PAINT IS TO BE SANDED FLUSH / SMOOTH AND SEALED AS REQUIRED TO PREVENT CONTINUED DISCOLORATION AND SEEPAGE
 - 8) NEW WOOD THAT WOULD BE IN CONTACT WITH THE STONE SILL SHOULD INSTEAD BE HELD UP APPROXIMATELY 1/8" PLASTIC SHIMS TO PREVENT MOISTURE WICKING, SHIMS ARE NOT TO BE VISIBLE IN FINISHED WORK
 - 9) PRIME, PAINT & SEAL WINDOWS & SEAL SURROUNDING JOINTS AFFECTED BY WORK

PROJECT

BASILICA OF ST. JOSAPHAT EXTERIOR REPAIR

St. Josaphat Basilica Foundation

SHEET

KEY PLAN - WINDOW REPAIR

DATE
7/16/18

PROJECT NO.
18-120

SHEET NO.

A3

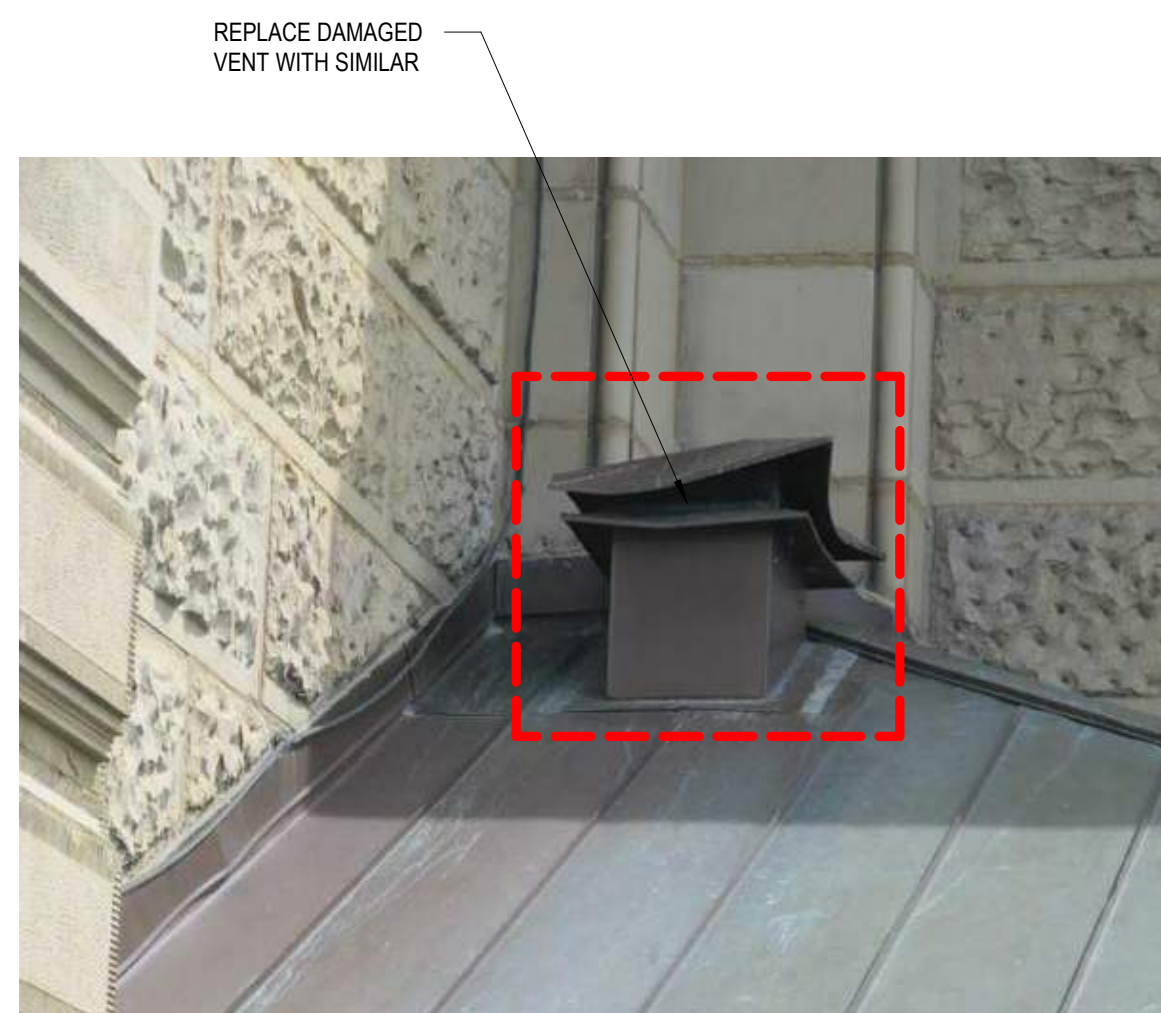
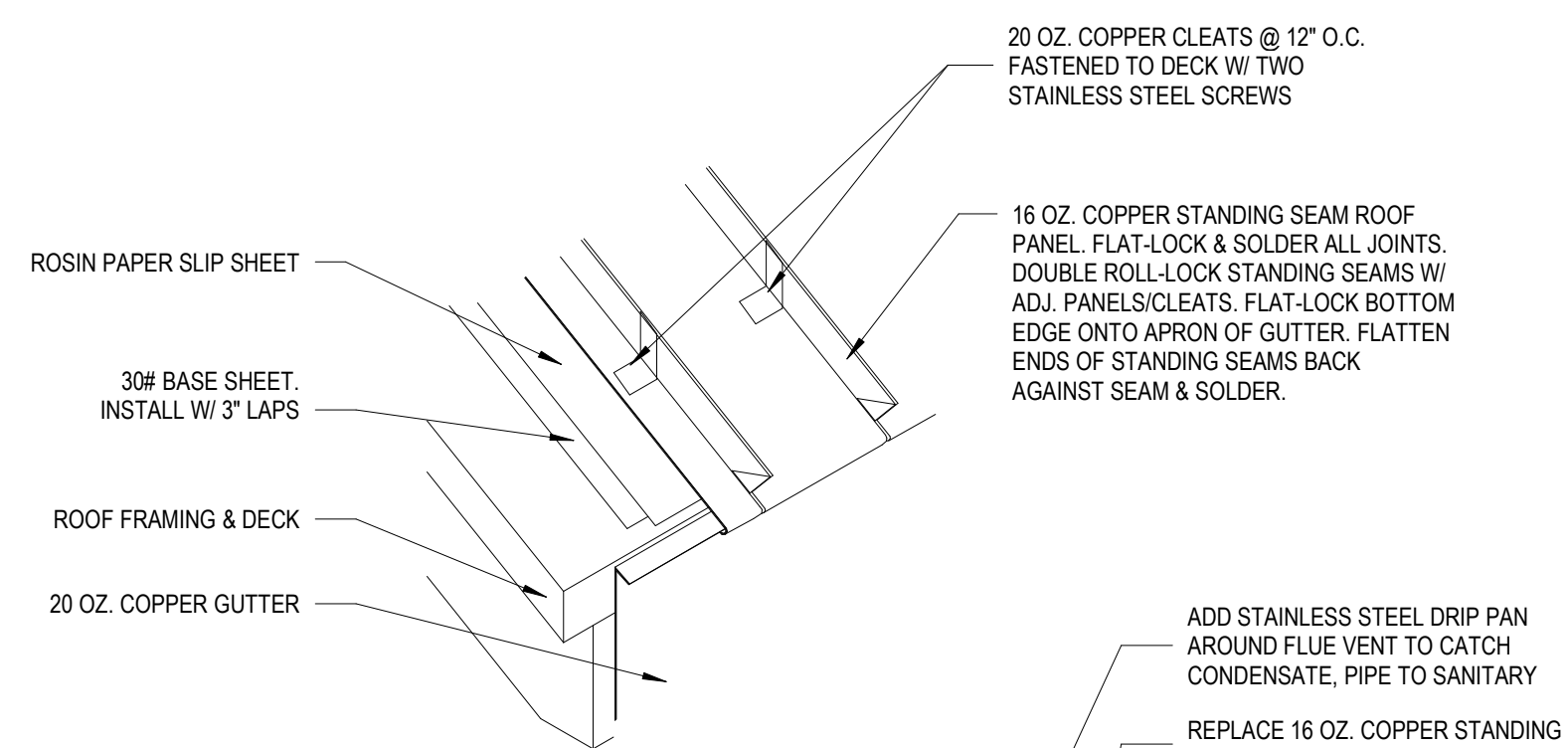

12 DETAIL @ W. SIDE ALTER ROOF VENT
1 1/2" = 1'-0"

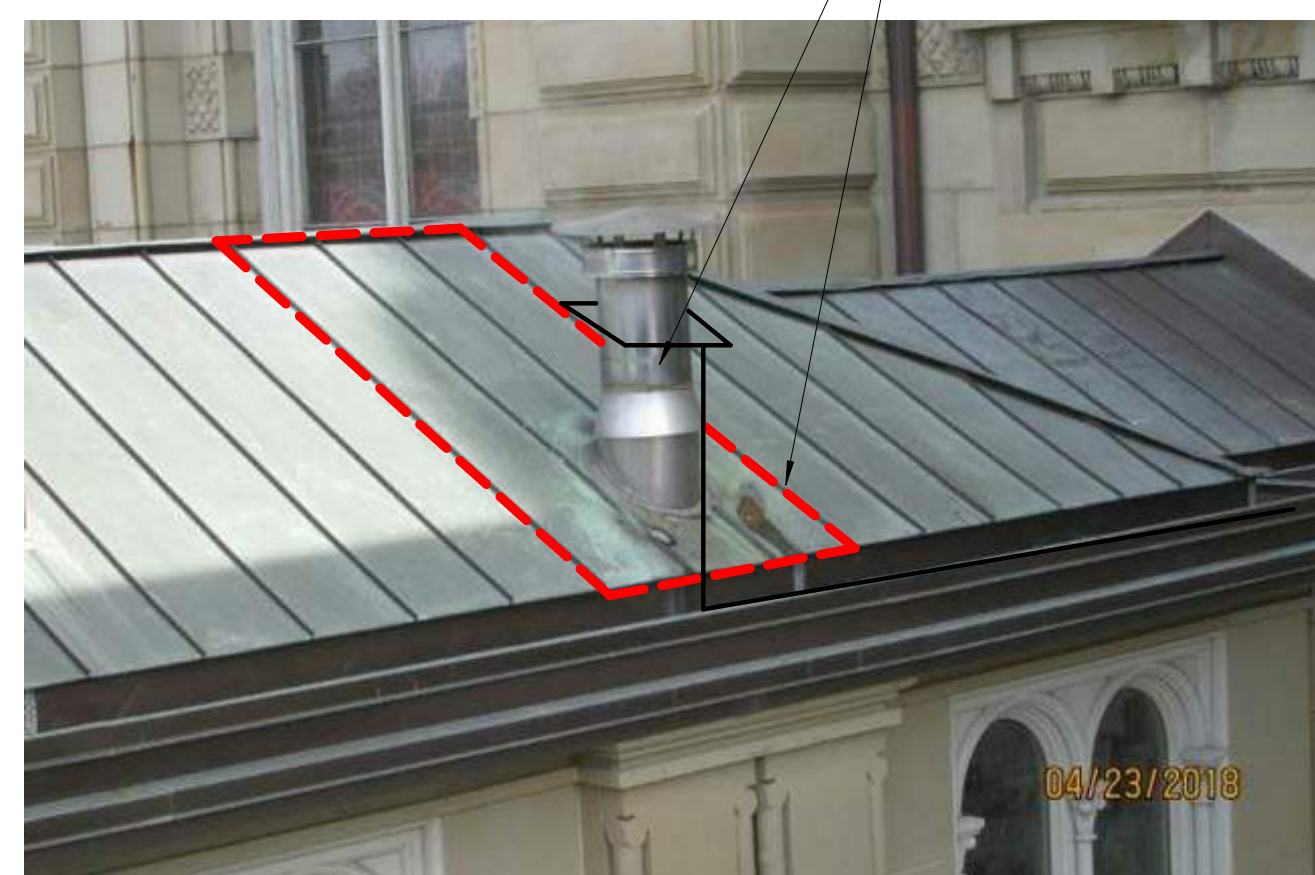

11 DETAIL @ EAST PAVILION ROOF GAS VENT
12" = 1'-0"

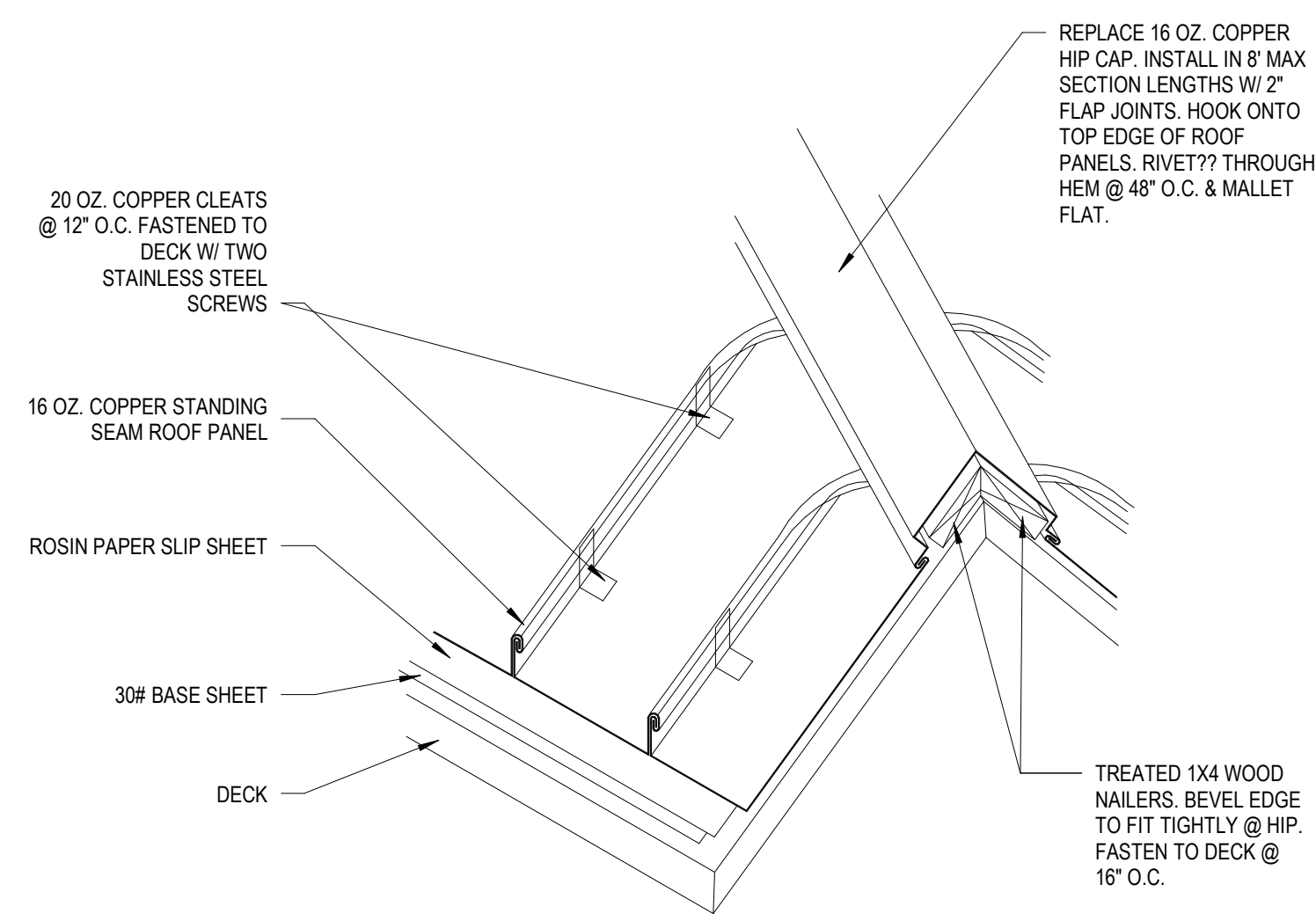

10 DETAIL @ EAST PAVILION ROOF RIDGE
12" = 1'-0"



9 DETAIL @ ROOF CORNER FLASHING
1 1/2" = 1'-0"

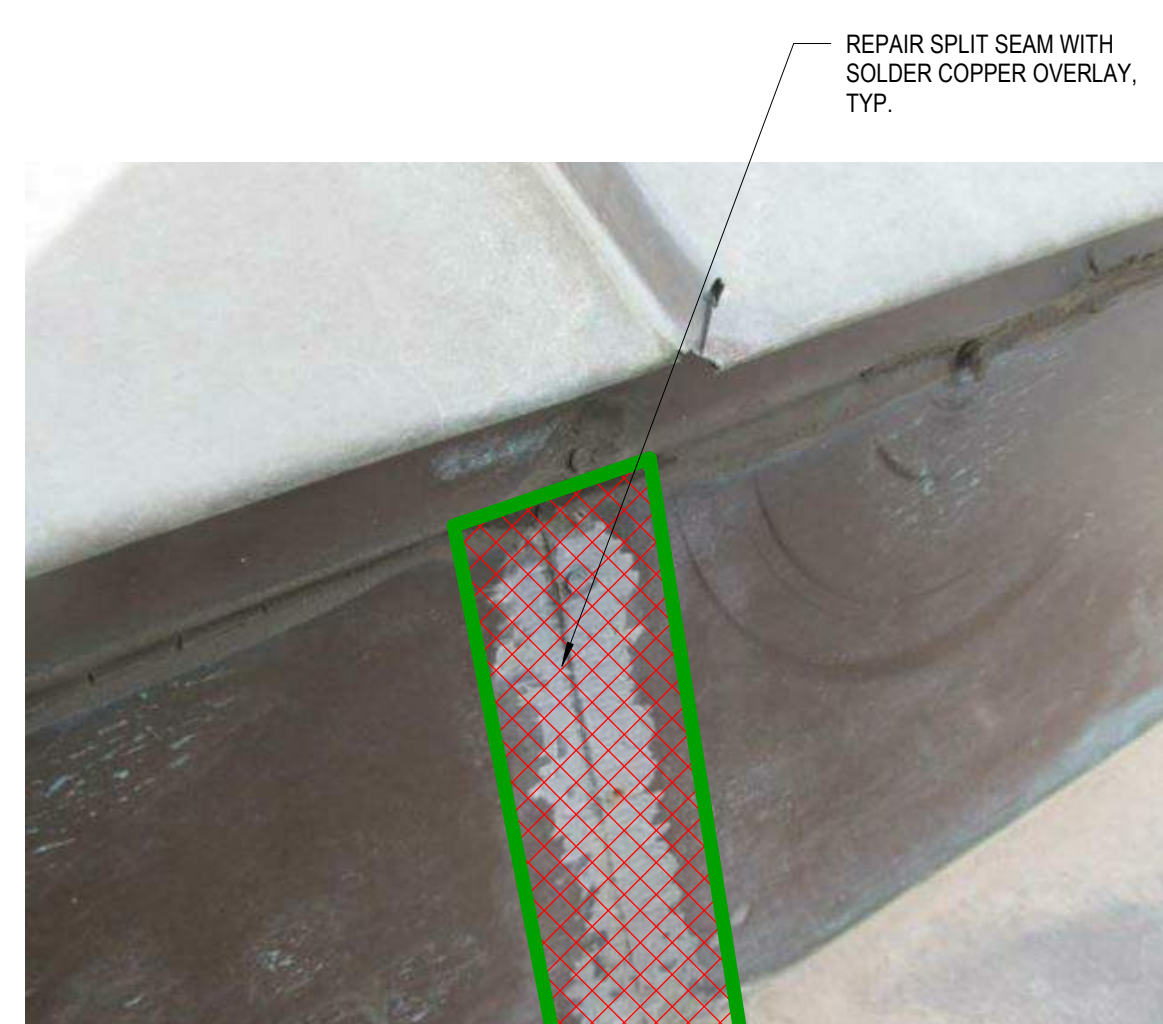

8 DETAIL @ PAVILION GUTTER, TYP.
1 1/2" = 1'-0"

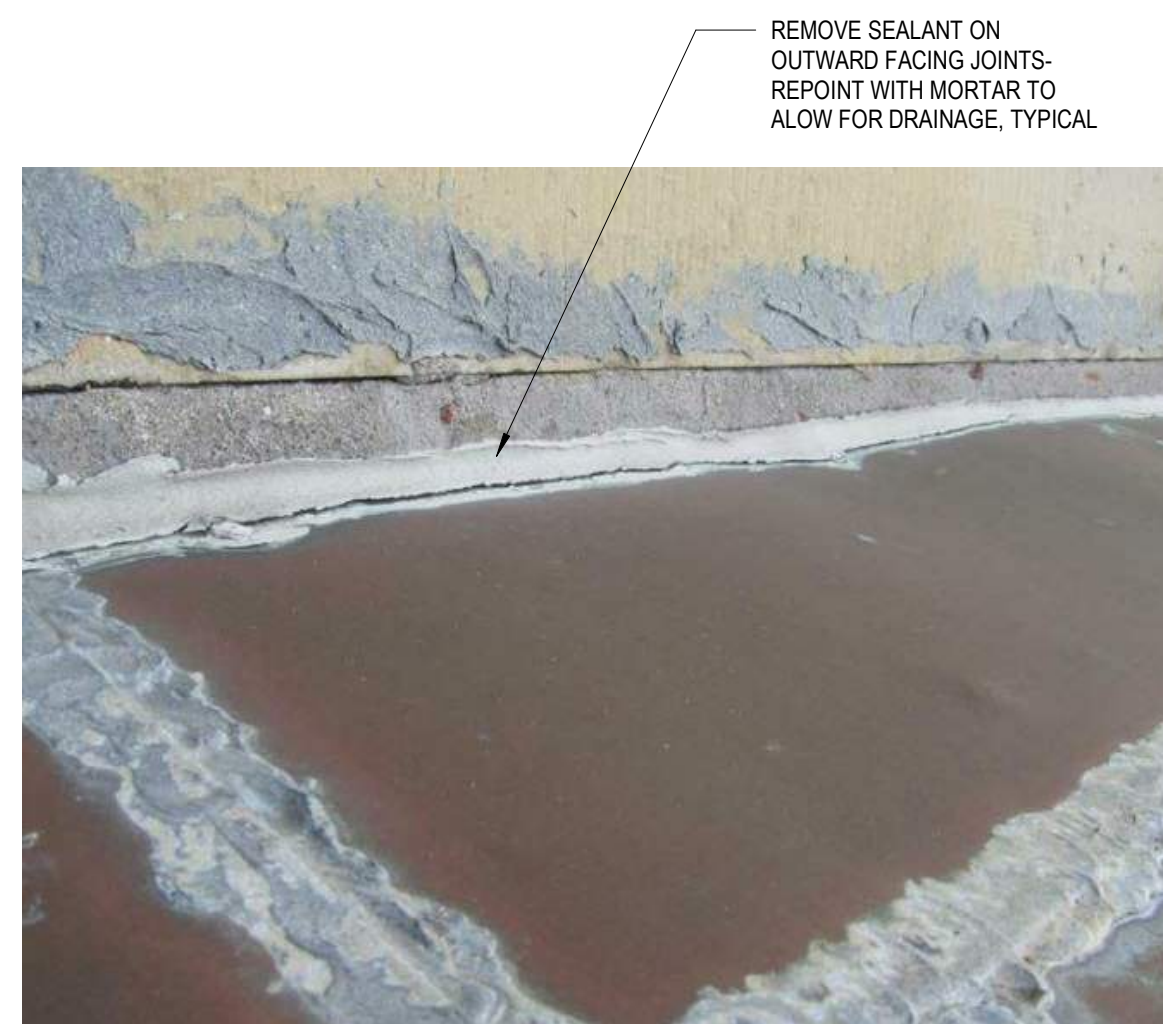

7 DETAIL @ WEST TRANCEPT LEDGE
1 1/2" = 1'-0"

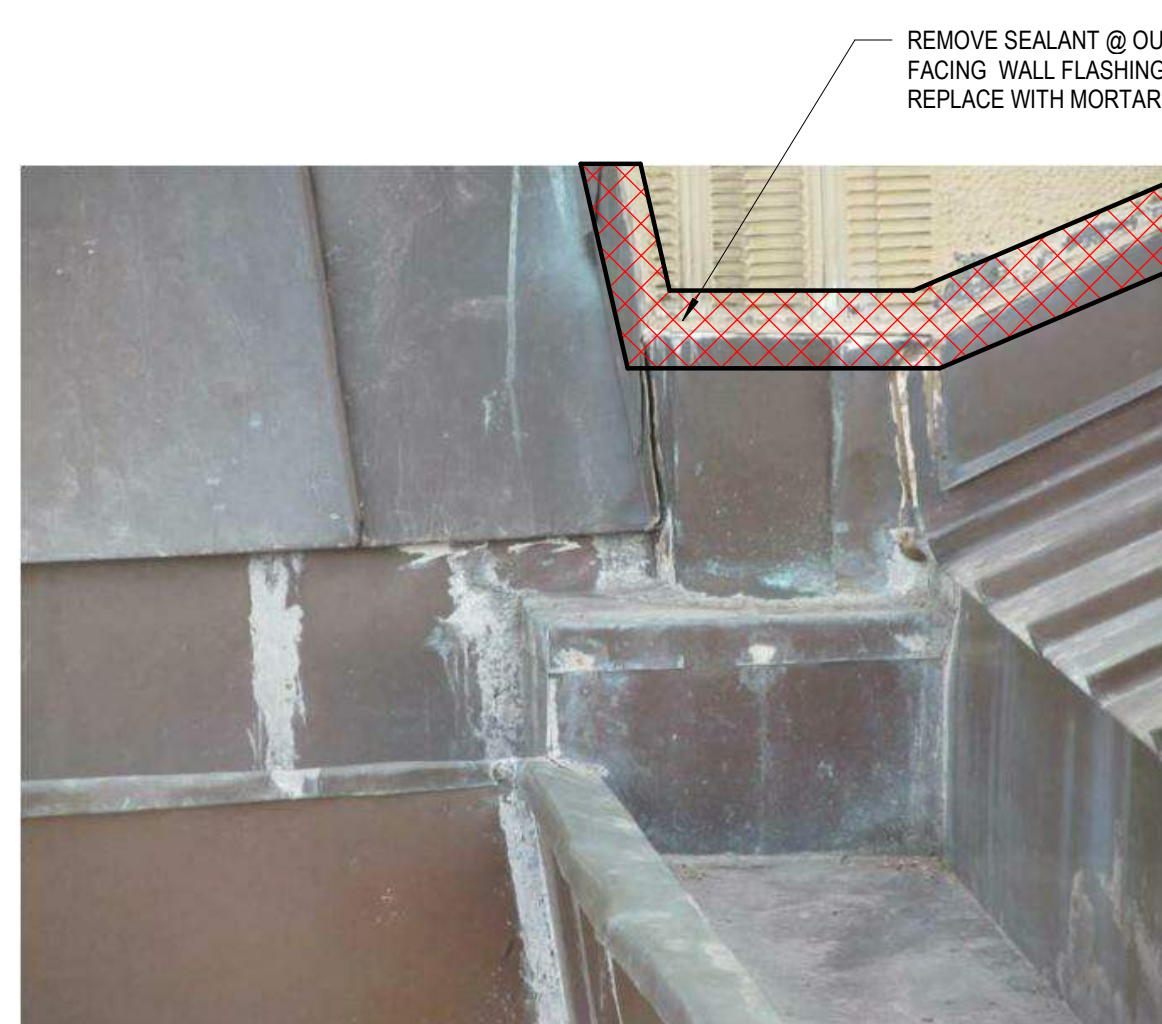

6 DETAIL @ INSIDE CORNER AISLE/TRANCEPT ROOF
1 1/2" = 1'-0"

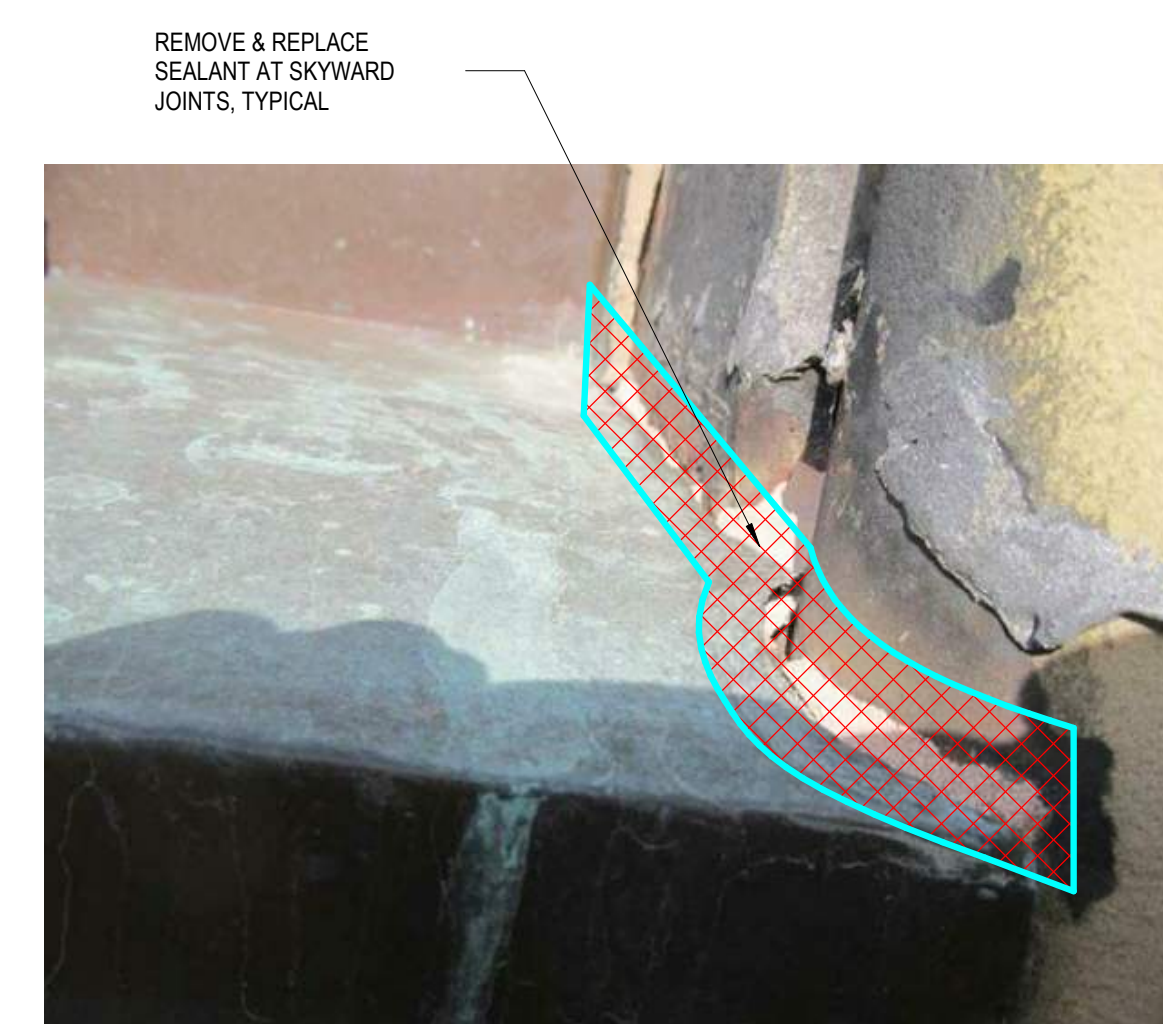

5 DETAIL @ EAST SACRISTY LEDGE
1 1/2" = 1'-0"

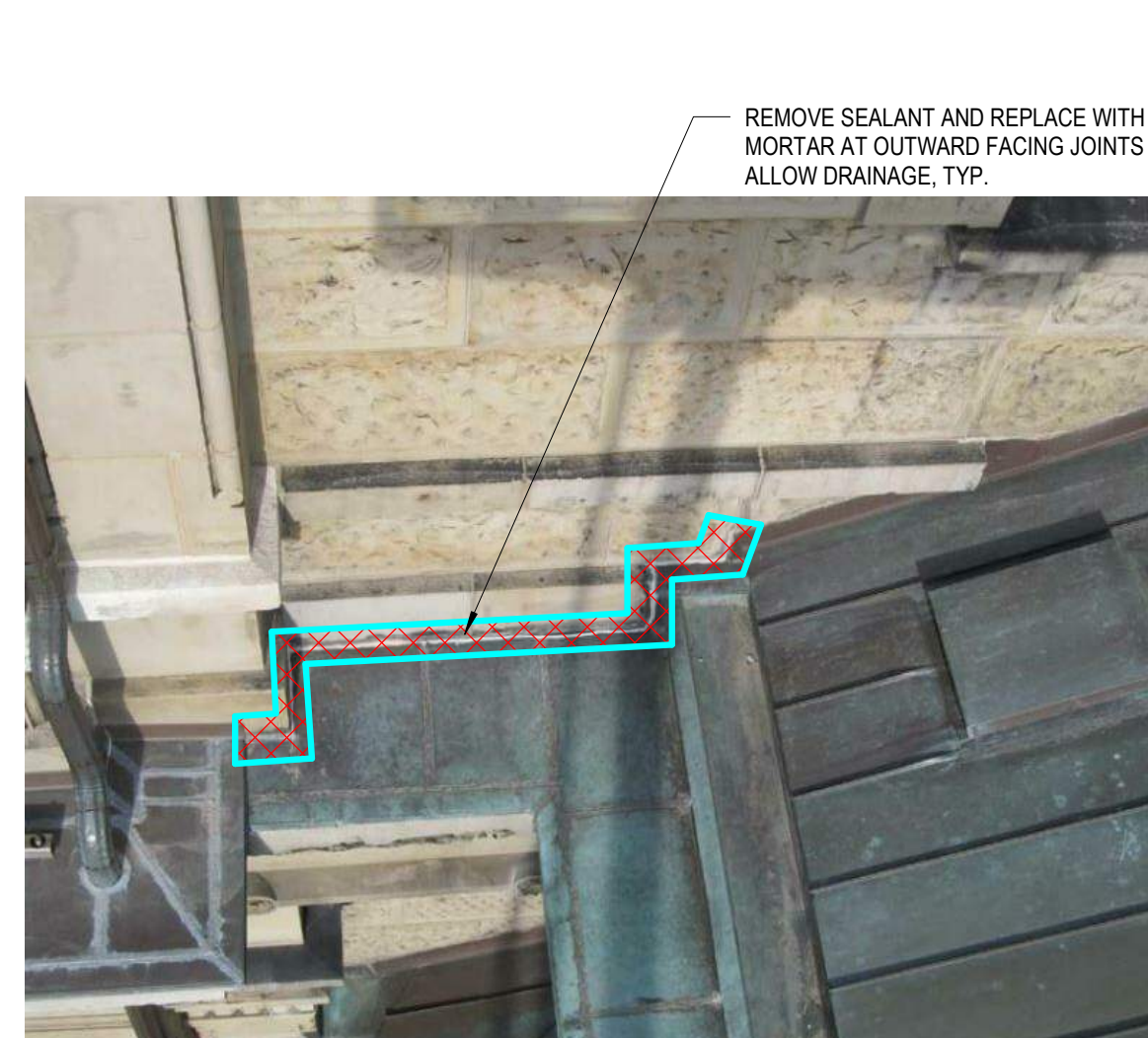

4 DETAIL @ SE TRANCEPT LEDGE
1 1/2" = 1'-0"

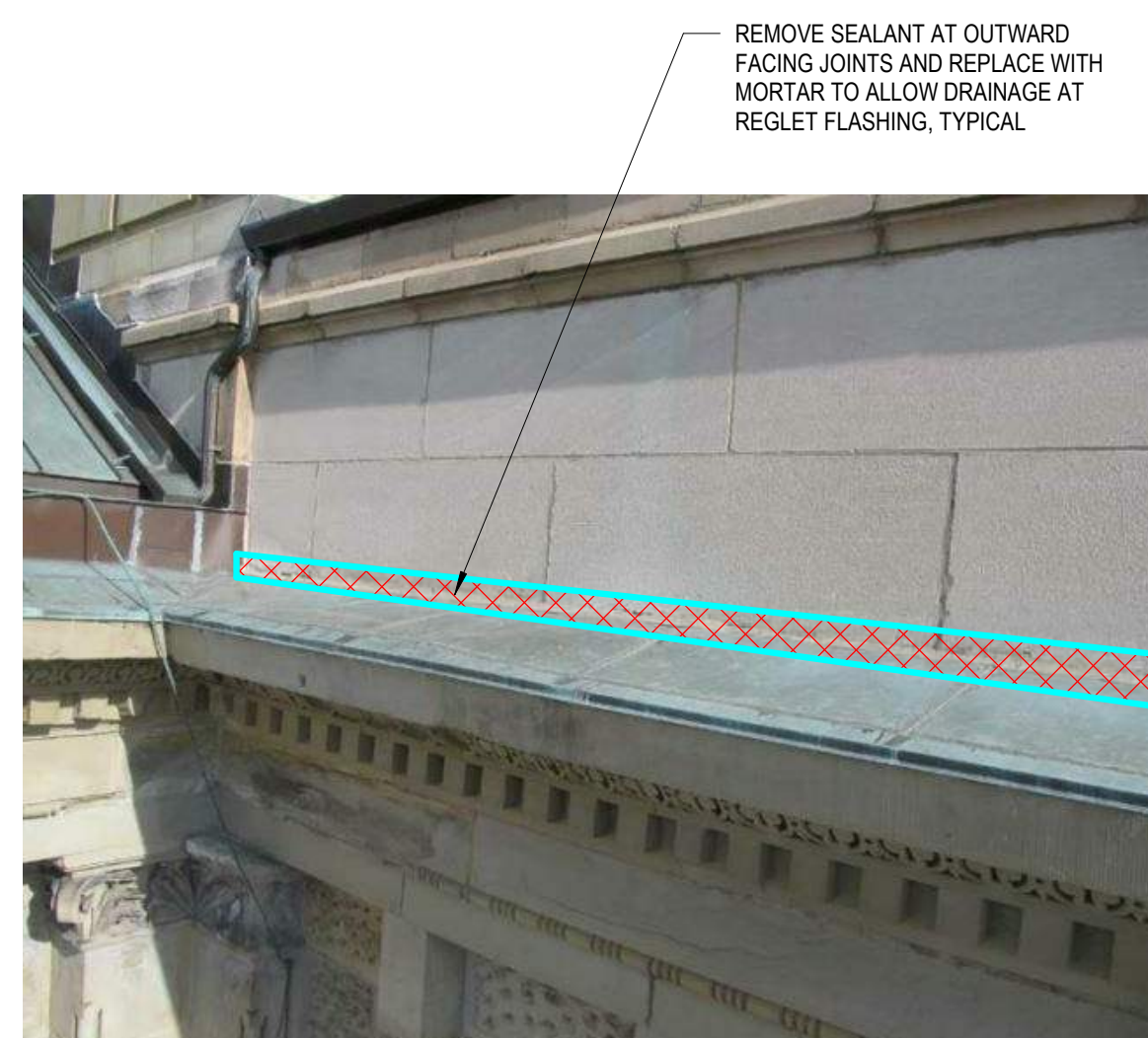

3 DETAIL @ SE CENTER ROOF
1 1/2" = 1'-0"

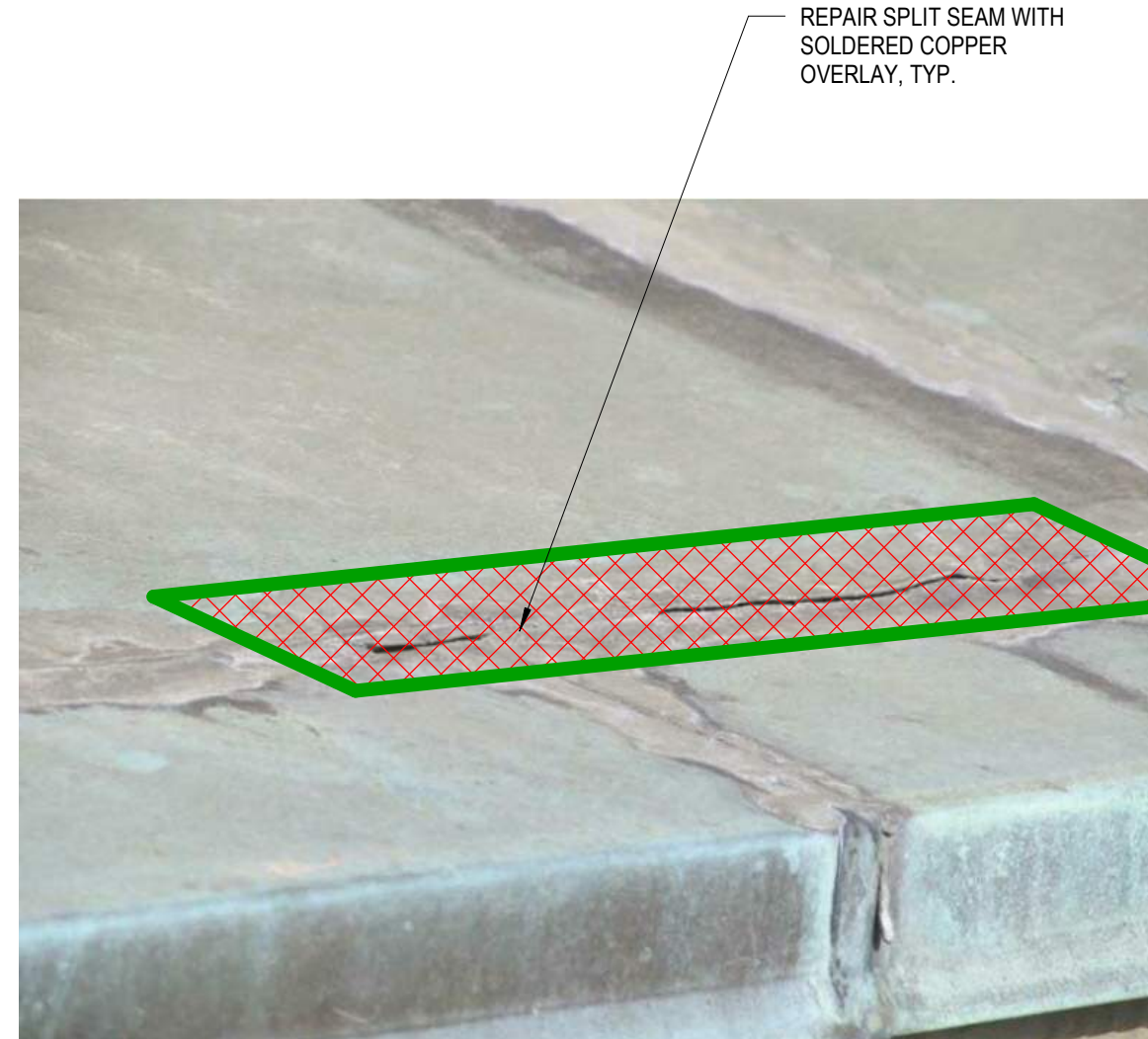

2 DETAIL @ SE CENTER ROOF SOLDERED SEAM
1 1/2" = 1'-0"

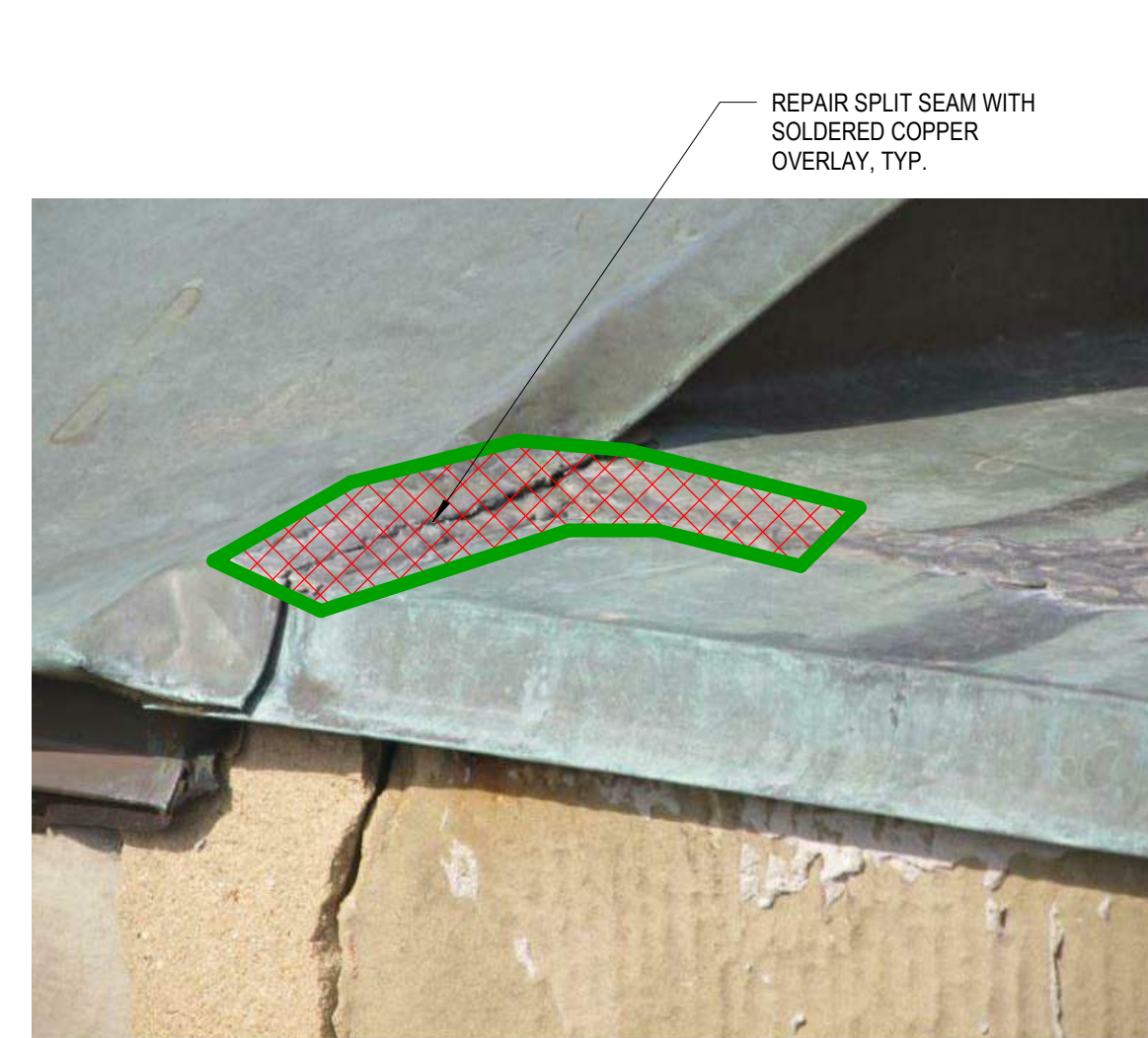

1 DETAIL @ SANCTUARY ROOF SOLDERED SEAM
1 1/2" = 1'-0"

PROJECT

BASILICA OF ST. JOSAPHAT EXTERIOR REPAIR

St. Josaphat Basilica Foundation

SHEET

ARCHITECTURAL DETAILS

DATE

7/16/18

PROJECT NO.

18-120

SHEET NO.

A4

KEYED NOTES

MARK	DESCRIPTION
①	FAILING/WEATHERED/LOOSE MORTAR IN JOINT. PROVIDE NEW TUCK POINTING. SEE DETAIL 1/S5.
②	SEALANT AT WRONG LOCATION. REMOVE SEALANT AND CLEAN. IF MORTAR LOSS NOTED, PROVIDE NEW TUCK POINTING PER DETAIL 1/S5.
③	FAILING SEALANT AT SKYWARD JOINT. REMOVE SEALANT, CLEAN, AND APPLY NEW SEALANT PER DETAIL 2/S5. IF MORTAR LOSS NOTED, PROVIDE NEW TUCK POINTING PRIOR TO APPLYING SEALANT.
④	SPALL IN STONE FROM ANCHORS BEING TOO CLOSE TO EDGE ALONG STONE PROJECTION. REMOVE LOOSE SPALL AND PREVENT MOISTURE INTRUSION.

NOTE:
1. SEE ROOFING CONSULTANT'S DETAIL FOR SEALANT AT COPPER FLASHING, TYP.
2. EXISTING PAINT IN ARCHED WINDOW FRAME HAS PEELED OFF. REMOVE PAINT, CLEAN, AND APPLY NEW BREATHABLE PAINT, TYP.

ISSUE:

NO.	DATE	DESCRIPTION
1	7/13/2018	BID DOCUMENTS

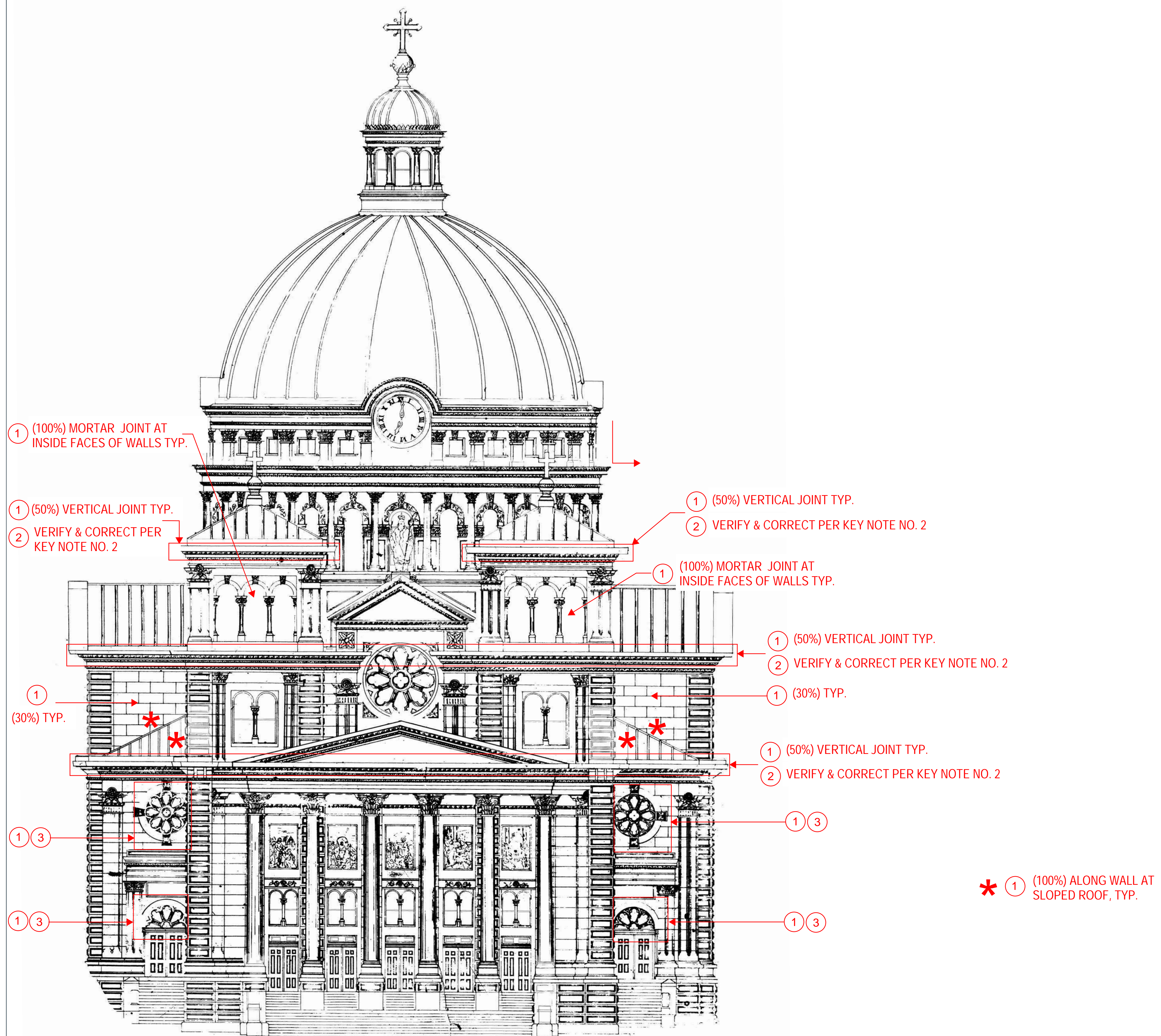

① NORTH ELEVATION
S1

ST. JOSAPHAT
BASILICA
FACADE REVIEW
2333 S. 6th STREET
MILWAUKEE, WI 53215

PE PROJECT: 18368

NORTH ELEVATION

SCALE: AS NOTED
DRAWN BY: PE
CHECKED BY: PE
S1

KEYED NOTES

MARK	DESCRIPTION
①	FAILING/WEATHERED/LOOSE MORTAR IN JOINT. PROVIDE NEW TUCK POINTING. SEE DETAIL 1/S5.
②	SEALANT AT WRONG LOCATION. REMOVE SEALANT AND CLEAN. IF MORTAR LOSS NOTED, PROVIDE NEW TUCK POINTING PER DETAIL 1/S5.
③	FAILING SEALANT AT SKYWARD JOINT. REMOVE SEALANT, CLEAN, AND APPLY NEW SEALANT PER DETAIL 2/S5. IF MORTAR LOSS NOTED, PROVIDE NEW TUCK POINTING PRIOR TO APPLYING SEALANT.
④	SPALL IN STONE FROM ANCHORS BEING TOO CLOSE TO EDGE ALONG STONE PROJECTION. REMOVE LOOSE SPALL AND PREVENT MOISTURE INTRUSION.

ISSUE:

NO.	DATE	DESCRIPTION
1	7/13/2018	BID DOCUMENTS

NOTE:

- SEE ROOFING CONSULTANT'S DETAIL FOR SEALANT AT COPPER FLASHING, TYP.
- EXISTING PAINT IN ARCHED WINDOW FRAME HAS PEELED OFF. REMOVE PAINT, CLEAN, AND APPLY NEW BREATHABLE PAINT, TYP.

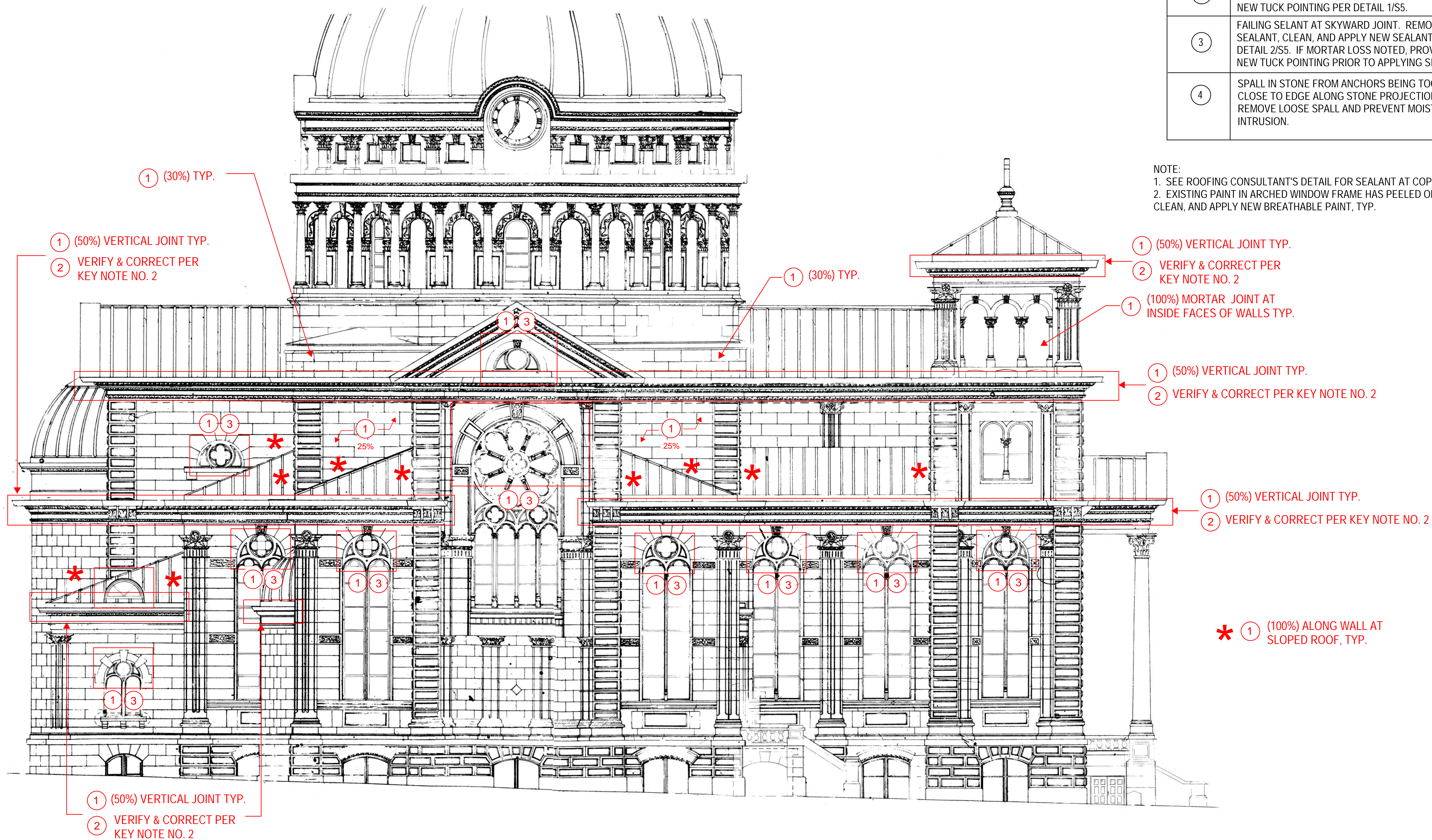

ST. JOSAPHAT
BASILICA

FACADE REVIEW

2333 S. 6th STREET
MILWAUKEE, WI 53215

PE PROJECT: 18368

EAST ELEVATION

SCALE: AS NOTED
DRAWN BY: PE
CHECKED BY: PE

S2

KEYED NOTES

MARK	DESCRIPTION
①	FAILING/WEATHERED/LOOSE MORTAR IN JOINT. PROVIDE NEW TUCK POINTING. SEE DETAIL 1/S5.
②	SEALANT AT WRONG LOCATION. REMOVE SEALANT AND CLEAN. IF MORTAR LOSS NOTED, PROVIDE NEW TUCK POINTING PER DETAIL 1/S5.
③	FAILING SEALANT AT SKYWARD JOINT. REMOVE SEALANT, CLEAN, AND APPLY NEW SEALANT PER DETAIL 2/S5. IF MORTAR LOSS NOTED, PROVIDE NEW TUCK POINTING PRIOR TO APPLYING SEALANT.
④	SPALL IN STONE FROM ANCHORS BEING TOO CLOSE TO EDGE ALONG STONE PROJECTION. REMOVE LOOSE SPALL AND PREVENT MOISTURE INTRUSION.

NOTE:

- SEE ROOFING CONSULTANT'S DETAIL FOR SEALANT AT COPPER FLASHING, TYP.
- EXISTING PAINT IN ARCHED WINDOW FRAME HAS PEELED OFF. REMOVE PAINT, CLEAN, AND APPLY NEW BREATHABLE PAINT, TYP.

ISSUE:

NO.	DATE	DESCRIPTION
1	7/13/2018	BID DOCUMENTS

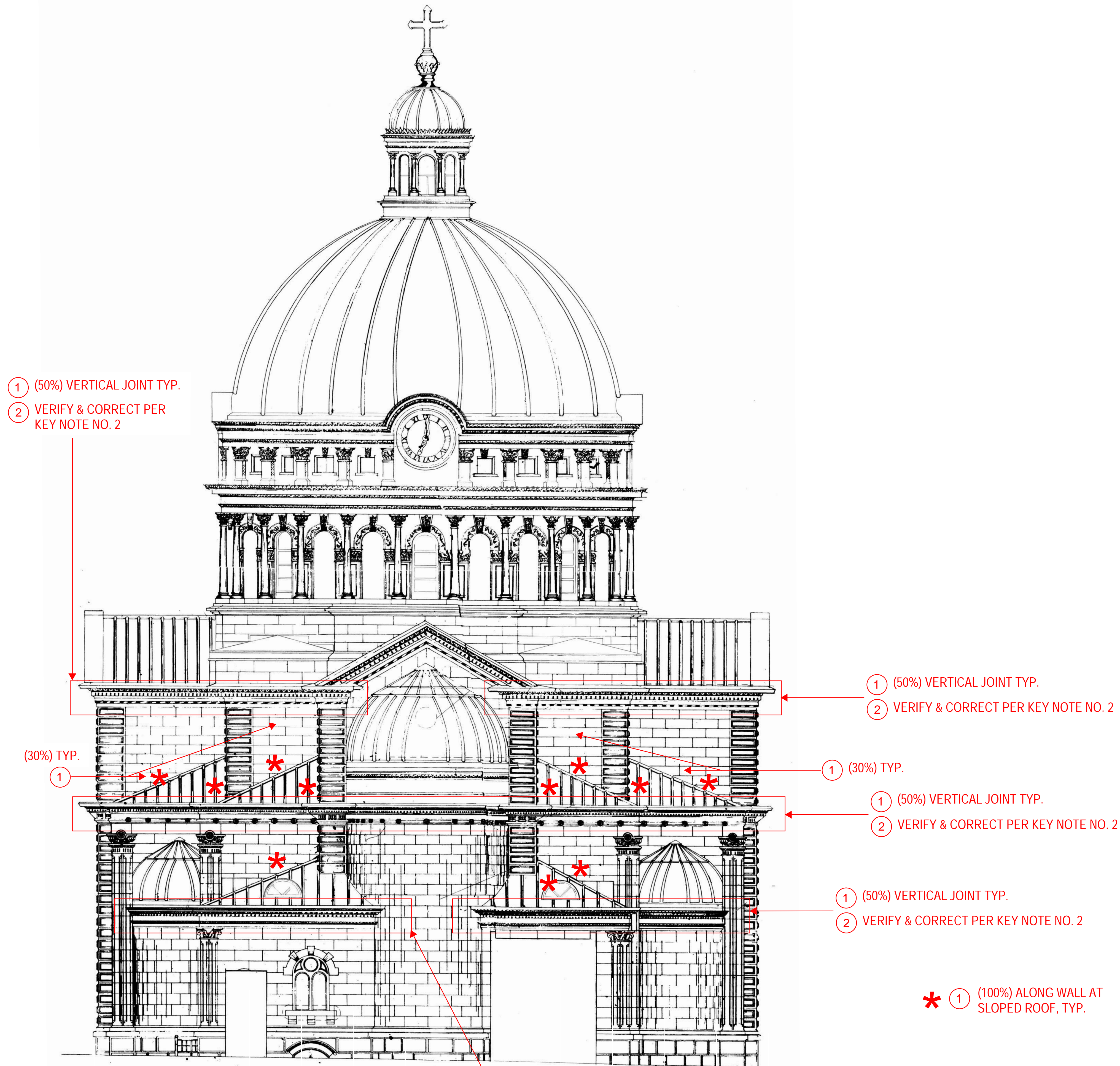

① (50%) VERTICAL JOINT TYP.
② VERIFY & CORRECT PER KEY NOTE NO. 2

① (50%) VERTICAL JOINT TYP.
② VERIFY & CORRECT PER KEY NOTE NO. 2

(30%) TYP.

①

① (30%) TYP.

① (50%) VERTICAL JOINT TYP.
② VERIFY & CORRECT PER KEY NOTE NO. 2

① (50%) VERTICAL JOINT TYP.
② VERIFY & CORRECT PER KEY NOTE NO. 2

* ① (100%) ALONG WALL AT SLOPED ROOF, TYP.

① SOUTH ELEVATION
S3

① (50%) VERTICAL JOINT TYP.
② VERIFY & CORRECT PER KEY NOTE NO. 2

ST. JOSAPHAT
BASILICA

FACADE REVIEW

2333 S. 6th STREET
MILWAUKEE, WI 53215

PE PROJECT: 18368

SOUTH ELEVATION

SCALE: AS NOTED
DRAWN BY: PE
CHECKED BY: PE

S3

KEYED NOTES

MARK	DESCRIPTION
①	FAILING/WEATHERED/LOOSE MORTAR IN JOINT. PROVIDE NEW TUCK POINTING. SEE DETAIL 1/S5.
②	SEALANT AT WRONG LOCATION. REMOVE SEALANT AND CLEAN. IF MORTAR LOSS NOTED, PROVIDE NEW TUCK POINTING PER DETAIL 1/S5.
③	FAILING SEALANT AT SKYWARD JOINT. REMOVE SEALANT, CLEAN, AND APPLY NEW SEALANT PER DETAIL 2/S5. IF MORTAR LOSS NOTED, PROVIDE NEW TUCK POINTING PRIOR TO APPLYING SEALANT.
④	SPALL IN STONE FROM ANCHORS BEING TOO CLOSE TO EDGE ALONG STONE PROJECTION. REMOVE LOOSE SPALL AND PREVENT MOISTURE INTRUSION.

NOTE:
 1. SEE ROOFING CONSULTANT'S DETAIL FOR SEALANT AT COPPER FLASHING, TYP.
 2. EXISTING PAINT IN ARCHED WINDOW FRAME HAS PEELED OFF. REMOVE PAINT, CLEAN, AND APPLY NEW BREATHABLE PAINT, TYP.

ISSUE:

NO.	DATE	DESCRIPTION
1	7/13/2018	BID DOCUMENTS

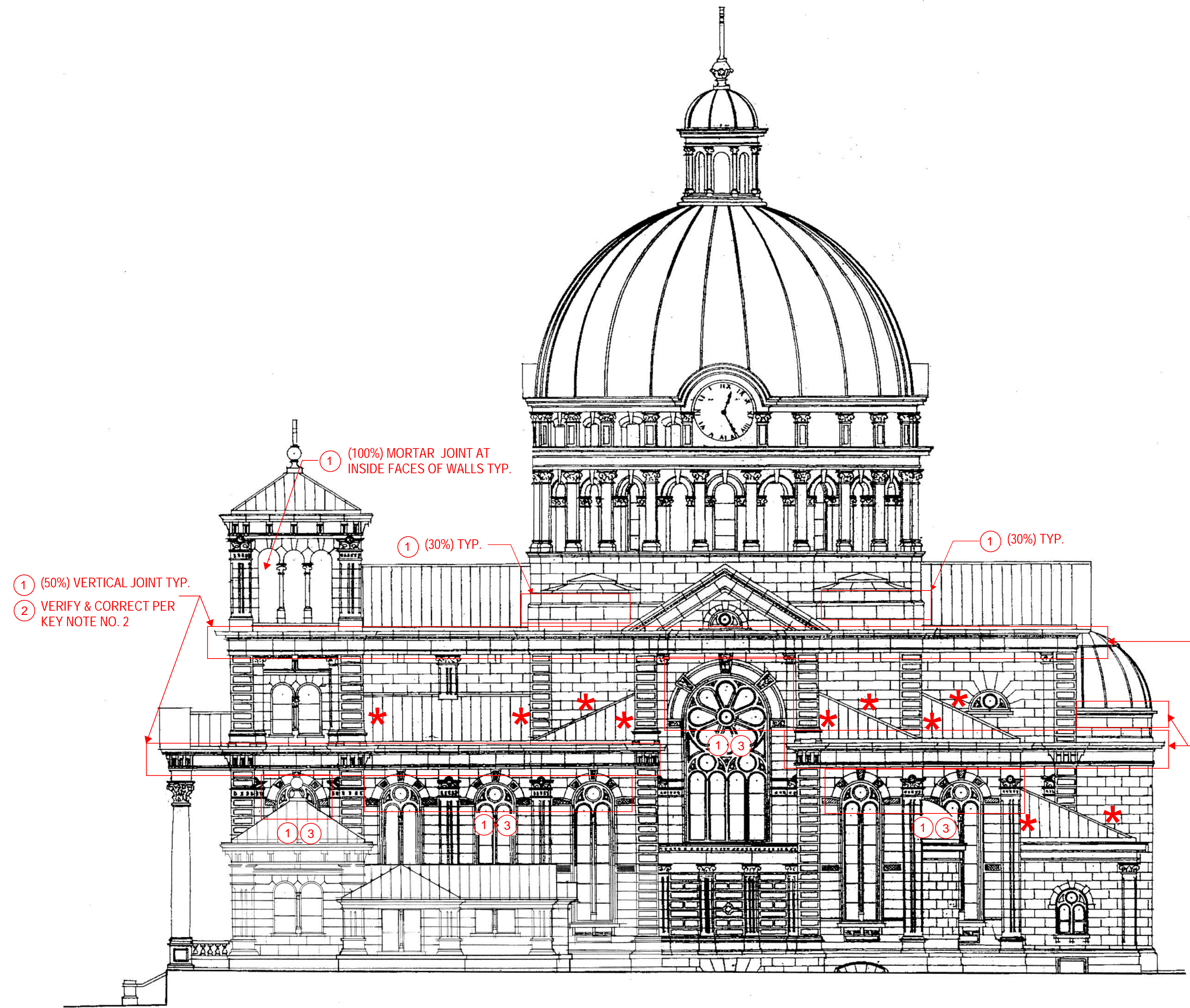

① WEST ELEVATION
 S4

ST. JOSAPHAT
 BASILICA
 FACADE REVIEW
 2333 S. 6th STREET
 MILWAUKEE, WI 53215

PE PROJECT: 18368

WEST ELEVATION

GENERAL REPAIR NOTES

1. CONTRACTOR TO SHORE ALL CONSTRUCTION AS REQUIRED TO SAFELY PERFORM ALL WORK.
2. CONTRACTOR IS TO LOCATE ALL AREAS OF DISREPAIR AND MARK AREAS ADEQUATELY.
3. ALL REPAIR MATERIALS, METHODS, BONDING AGENTS, SEALANTS, SEALERS, ETC MUST BE APPROVED BY THE STRUCTURAL ENGINEER PRIOR TO USE ON THE BUILDING STRUCTURE.
4. CONTRACTOR MUST NOTIFY THE STRUCTURAL ENGINEER IMMEDIATELY IF ANY ITEMS UNCOVERED DURING CONSTRUCTION REPRESENT POTENTIAL STRUCTURAL CONCERNS.
5. STRUCTURAL ENGINEER SHALL BE NOTIFIED PRIOR TO PLACING ANY REPAIR MATERIALS IN ORDER TO VERIFY PROPER PROCEDURES ARE BEING FOLLOWED.
6. ALL MANUFACTURER RECOMMENDATIONS MUST BE FOLLOWED WHEN PLACING AND PREPARING FOR REPAIR MATERIALS.
7. ALL EXPOSED/CORRODED EXISTING REINFORCING MUST BE CLEANED AND COATED WITH A ZINC RICH PRIMER. EXISTING EPOXY COATING THAT HAS BEEN COMPROMISED MUST BE REMOVED AND ALL EXPOSED STEEL COATED WITH A ZINC RICH PRIMER.
8. ALL NEW STONE ANCHORS SHALL BE STAINLESS STEEL.
9. CONTRACTOR TO CLEAN THE AREA OF WORK AFTER THE COMPLETION OF ALL REPAIR WORK.

MATERIAL DESIGN PROPERTIES

STONE MASONRY STRENGTHS:

LIME MORTAR (1 PART LIME : 3 PARTS SAND)	
COMPRESSIVE STRENGTH	15,000 psi (MIN.)
WATER ABSORPTION	5 % (MAX.)
MODULUS OF RUPTURE	1,300 psi (MIN.)
REPLACEMENT STONE TO MATCH EXISTING STONE IN STRENGTH, TEXTURE, AND, COLOR AS MUCH AS POSSIBLE	

STRUCTURAL STEEL STRENGTHS:

STAINLESS STEEL ANCHORS (SS 316)	Fy = 30,000 psi
----------------------------------	-----------------

STANDARD ABBREVIATIONS

ABBREVIATION	WORD OR PHRASE
&	AND
DIA.	DIAMETER
ETC.	ET CETRA
MAX.	MAXIMUM
MIN.	MINIMUM
SS	STAINLESS STEEL
TYP.	TYPICAL



ISSUE:

NO.	DATE	DESCRIPTION
1	7/13/2018	BID DOCUMENTS

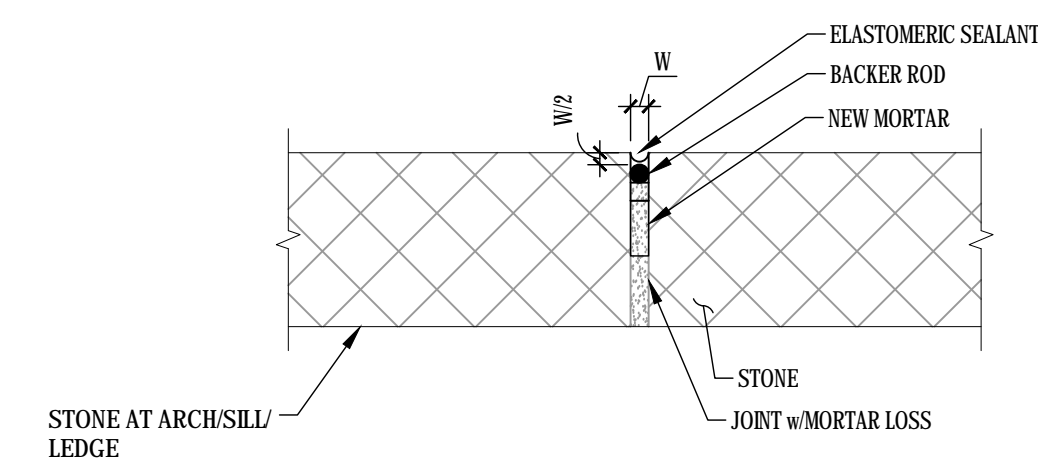

2
S5 SKYWARD JOINT SEALING DETAIL

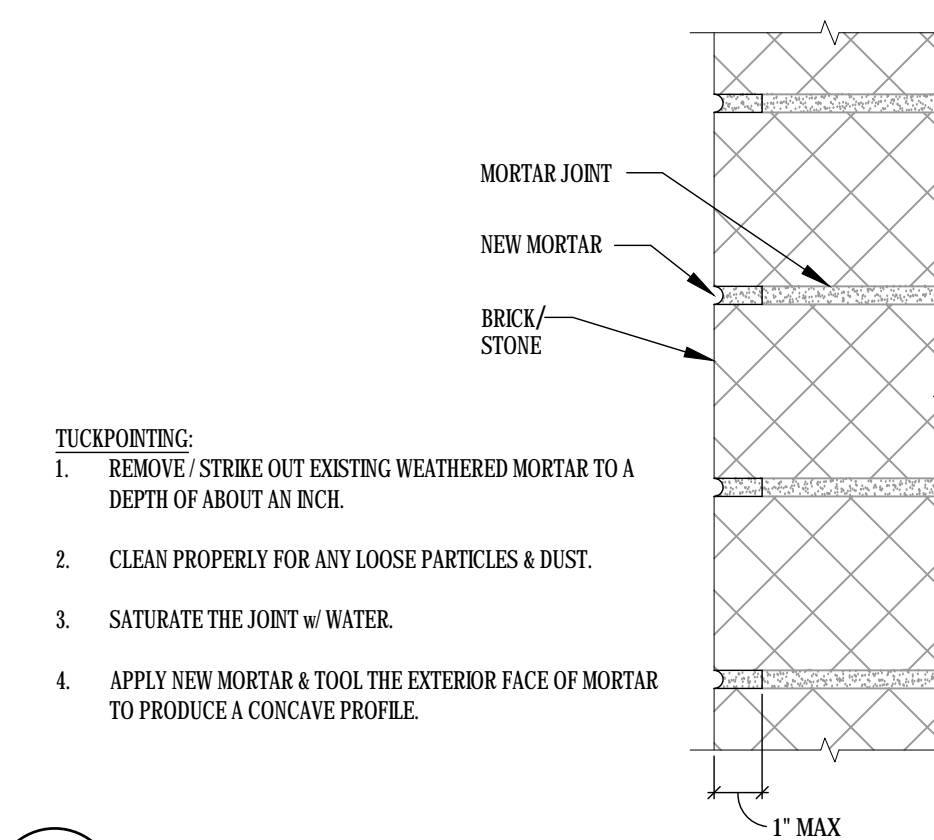

1
S5 TUCKPOINTING DETAIL

**ST. JOSAPHAT
BASILICA**

**FACADE
REHABILITATION**

2333 S. 6th STREET
MILWAUKEE, WI 53215

PE PROJECT: 18368

SCALE: AS NOTED
DRAWN BY: PE
CHECKED BY: PE

S5