



MEMORANDUM

LEGISLATIVE REFERENCE BUREAU

WWW.MILWAUKEE.GOV/LRB

To: Ald. Bohl
From: Kathleen Brengosz – Fiscal Planning Specialist
Date: March 23, 2011
Subject: Foundation Drain Disconnection Alternatives

My research was unable to identify any viable alternatives to the construction of a basement sump when disconnecting foundation drains from the sewer system. Two commonly used structures to handle clear water are dry wells and cisterns. While each of them has useful applications, their use is not easily adapted to collecting water from below the surface in a residential setting.

A dry well is a passive underground structure that disposes of unwanted water. It receives water from one or more entry pipes or channels at its top. Water is discharged through the sides and bottom of the dry well. Simple dry wells consist of a pit filled with gravel, riprap, rubble or other debris. Dry wells of this type do not have much storage capacity. A more advanced dry well consists of a reinforced concrete cylinder with perforated sides and bottom. Dry wells are usually buried completely, so that they do not take up any land area. Because dry wells are gravity fed, they must be constructed below the water's point of entry. Installing a dry well to accept foundation drain water would require significant excavation.

Cisterns are receptacles for water. They are commonly used for irrigation and for collecting rain in areas that have limited rainfall. Rain barrels are a type of cistern. Cisterns are not a practical alternative to sump construction. A buried cistern would function much like a sump. Water from the foundation drain would collect in the cistern and be pumped out when the cistern reached its capacity. It would require significant excavation to install. In addition, the pumping mechanism would be inaccessible from the house making maintenance and repairs problematic. An above ground cistern would require the installation of a sump or similar structure to facilitate the pumping of water from the foundation to the surface. In homes with older electrical systems, upgrades may be required to facilitate the installation of the cistern's pumping mechanism.

The primary difficulty with disposing of foundation drain water is its location beneath the surface. The installation of any gravity fed structure outside the house would require significant excavation. Pumping the water to the surface would require the installation of an underground collection point and a pumping mechanism. Both of these options are likely to be cost prohibitive. In addition, the repair and maintenance of underground structures is more problematic relative to sumps which are located within the house.

I have included diagrams of drywells, cisterns and sumps for comparison.

Drywell Diagrams

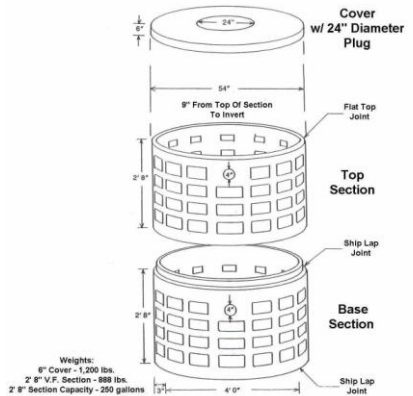
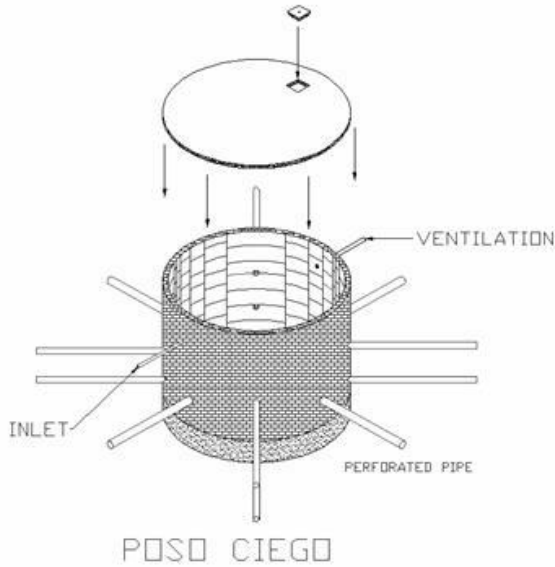
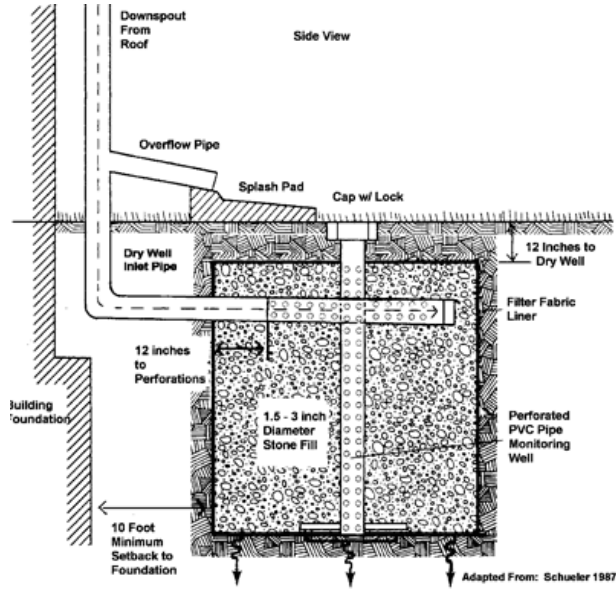

4' 0" Inside Diameter Drywell

Grimm Building Materials Co., Inc.
 Phone - (518) 272-3100 Fax - (518) 272-9229
 Precast Concrete Division
 96 Albany Avenue
 P.O. Box 157
 Green Island - Troy, New York 12181
 www.grimmbldg.com

Cistern Diagrams

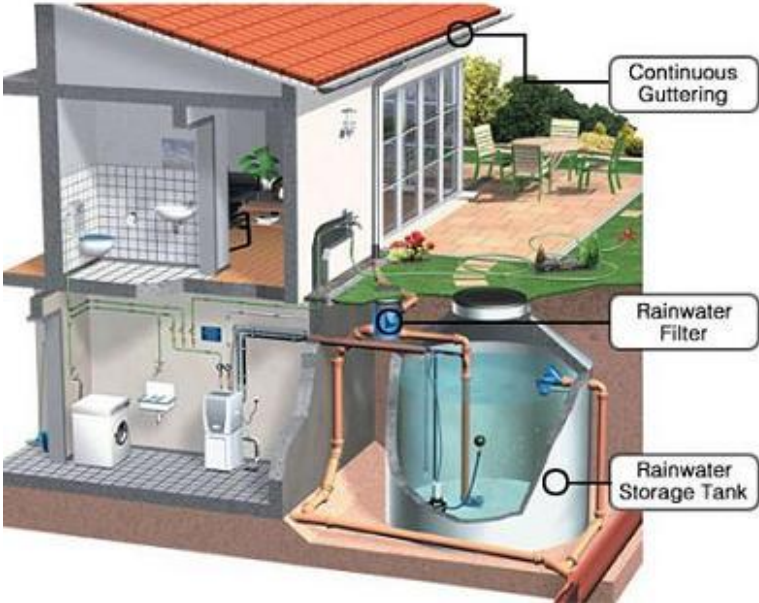
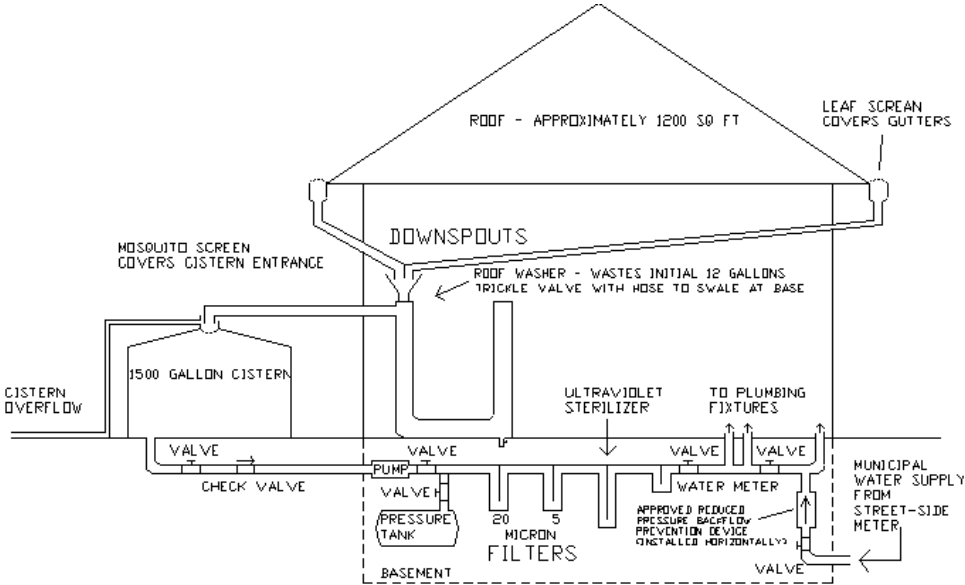

Sump Diagram

