



LIVING WITH HISTORY

# Certificate of Appropriateness

Milwaukee Historic Preservation Commission/200 E. Wells Street/Milwaukee, WI 53202/phone 414-286-5712/fax 414-286-3004

**Property** 129 W. BROWN ST. **Brewers Hill Historic District**  
**Description of work** Replace defective roof boards on side porch. Install new 3-tab shingles as temporary only until new roof is installed on house. Install new 6 x 6 porch posts in place of the existing 4 x 4 posts. Install 4 x6 beams at perimeter in place of existing wood beam.  
**Date issued** 8/2/2013 PTS ID 89109 COA, side porch repairs

In accordance with the provisions of Section 320-21 (11) and (12) of the Milwaukee Code of Ordinances, the Milwaukee Historic Preservation Commission has issued a certificate of appropriateness for the work listed above. The work was found to be consistent with preservation guidelines. The following conditions apply to this certificate of appropriateness:

All work will be done according to specifications and photos contained in this COA. All wood will be painted upon completion. Please note that when new wood is left exposed to the exterior elements for only a week or two, the life of the paint job subsequently applied to it will be decreased. A skirting (see attached drawing) must be installed on the back side of the rear porch stoop.

All work must be done in a craftsman-like manner, and must be completed according to the requirements of the Department of Neighborhood Services. Staff must approve any changes or additions to this certificate before work begins. Work that is not completed in accordance with this certificate may be subject to correction orders or citations. If you require technical assistance, please contact Paul Jakubovich of the Historic Preservation staff as follows: Phone: (414) 286-5712 Fax: (414) 286-3004 E-mail: [pjakub@milwaukee.gov](mailto:pjakub@milwaukee.gov). If permits are required, you are responsible for obtaining them from the Milwaukee Development Center. If you have questions about permit requirements, please consult the Development Center's web site, [www.milwaukee.gov/build](http://www.milwaukee.gov/build), or call (414) 286-8210.

Paul Jakubovich  
City of Milwaukee Historic Preservation

Copies to: Development Center, Ald. Milele Coggs, Contractor JV Home Improvement, Inspector Bret Radke (286-2553), Inspector Heidi Weed



**Install new smooth, 4.6 wood beams to support upper porch deck**

**Install new smooth 6 x 6 wood posts at outside corners of porch in place of existing posts**

**Install wood skirting (see attached drawing) to close off back of concrete stoop**

# Porches



## Porch Skirting

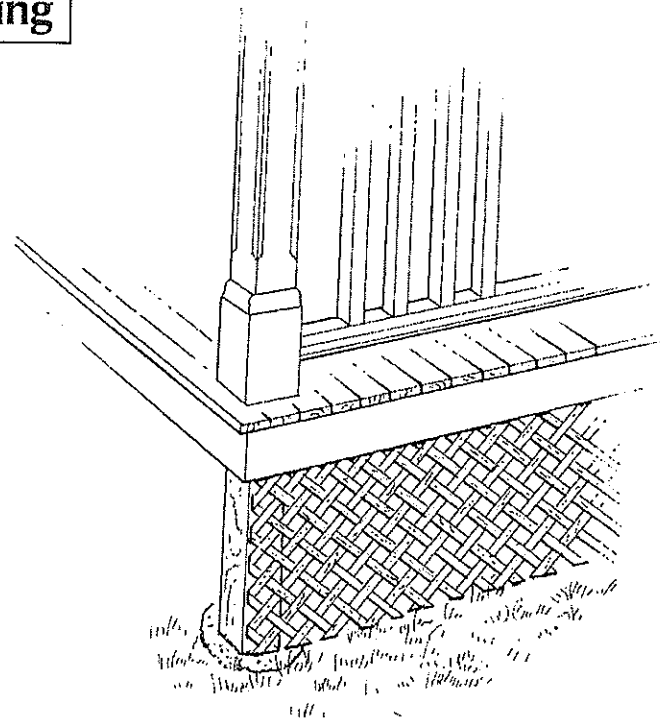
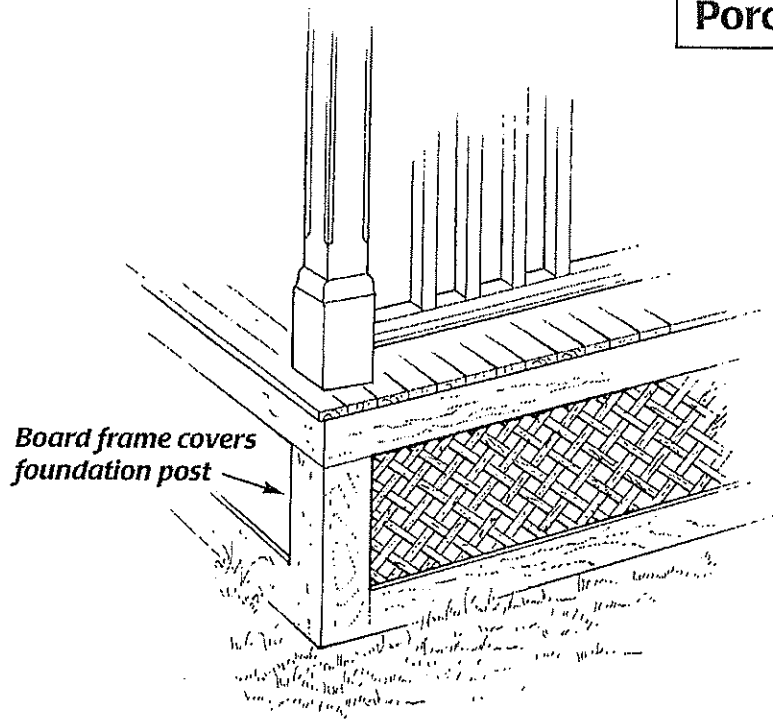

*Skirting, such as this lattice panel, enclosed the area beneath the porch floor. It should always be installed with a continuous board frame around it that is wide enough to cover the rough framing lumber that supports the porch deck.*

*Do not install a lattice skirting without a frame around it. The rough framing lumber that supports the porch will show through and the raw edges of the lattice look unfinished.*

**Detail of skirting to be installed on back side of porch**



**Replace defective roof sheathing boards with new, wood 1 x material. All new wood must be painted upon completion.**