



LIVING WITH HISTORY

Certificate of Appropriateness

Milwaukee Historic Preservation Commission/200 E. Wells Street/Milwaukee, WI 53202/phone 414-286-5712/fax 414-286-3004

Property	1630 E. ROYALL PL.	Charles Allis House
Description of work	Replace non-original light fixture above south entrance with new fixture shown below.	
Date issued	11/8/2018	PTS ID 114655 COA: replace lamp

In accordance with the provisions of Section 320-21 (11) and (12) of the Milwaukee Code of Ordinances, the Milwaukee Historic Preservation Commission has issued a certificate of appropriateness for the work listed above. The work was found to be consistent with preservation guidelines. The following conditions apply to this certificate of appropriateness: N/A

All work must be done in a craftsman-like manner, and must be completed within one year of the date this certificate was issued. Staff must approve any changes or additions to this certificate before work begins. Work that is not completed in accordance with this certificate may be subject to correction orders or citations. If you require technical assistance, please contact Historic Preservation staff as follows: Phone: (414) 286-5712 E-mail: hpc@milwaukee.gov.

If permits are required, you are responsible for obtaining them from the Milwaukee Development Center. If you have questions about permit requirements, please consult the Development Center's web site, www.milwaukee.gov/build, or call (414) 286-8210.

City of Milwaukee Historic Preservation Staff

Copies to: Development Center, Ald. Nik Kovac, Contractor, Inspector Paul Wolfgramm (286-2590)



Photograph of Charles Allis
Residence prior to addition.

Royall Place elevation with light fixture not extant, c. 1980.

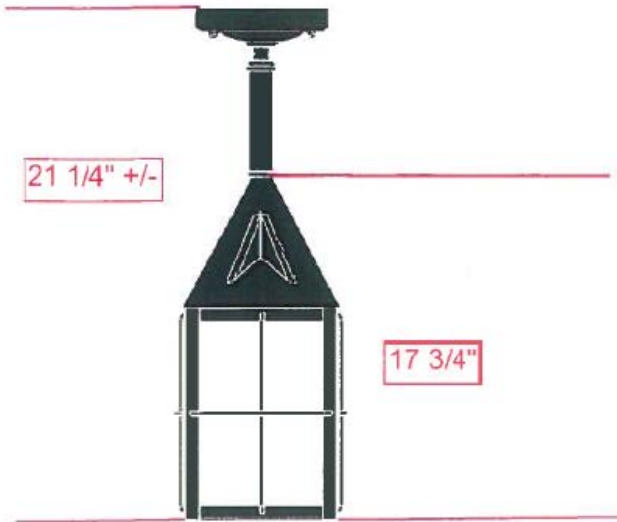

Existing fixture and location at right. Replacement above, replacement will be brass with a similar finish to the present fixture.



Existing south entrance light fixture. Proposing to replace with a new fixture more appropriate to the time period of the original Charles Allis Residence.