



# Certificate of Appropriateness

Milwaukee Historic Preservation Commission/841 N Broadway/Milwaukee, WI 53202/phone 414-286-5722

## Property

**2465 W. Congress Street and 4381 N. 25<sup>th</sup> Street, Garden Homes Historic District**

## Description of work

Replace the framing, posts, rails, decorative cross-buck railing, decking, and stairs on both porches of the duplex to match the design of the historic porches. Balusters cannot be outside mounted to the rails. Treated wood used only for structural framing and not on visible portions of the porch. No work on the porch roofs at this time but future work will be submitted to HPC for approval.

## Date issued

**4/23/2024**

In accordance with the provisions of Section 320-21 (11) and (12) of the Milwaukee Code of Ordinances, the Milwaukee Historic Preservation Commission has issued a certificate of appropriateness for the work listed above. The work was found to be consistent with preservation guidelines. The following conditions apply to this certificate of appropriateness:

**All finish wood must be smooth and free of knots and must be painted or treated with an opaque stain upon completion. Note: when new, bare wood is left exposed to the exterior elements for a period of only a week or two, the life of the paint job subsequently applied to it will be decreased. The use of a decay-resistant wood for is required for porch areas. Using western white pine or Ponderosa pine is "at your own risk" because this wood has no natural decay resistance and can deteriorate in some exterior settings in just a few years.**

All work must be done in a craftsman-like manner. Staff must approve any changes or additions to this certificate before work begins. Work that is not completed in accordance with this certificate may be subject to correction orders or citations. If you require technical assistance, please contact Historic Preservation staff as follows: Phone: (414) 286-5722 E-mail: [hpc@milwaukee.gov](mailto:hpc@milwaukee.gov).

## Permits and timeline

You are responsible for determining if permits are required and obtaining them prior to commencing work. Consult the Development Center on the web or by telephone for details: [www.milwaukee.gov/lms](http://www.milwaukee.gov/lms) - (414) 286-8210. If permits are not required, work must be completed within one year of the date this certificate was issued. If permits are required, permits must be obtained within one year of the date this certificate was issued.

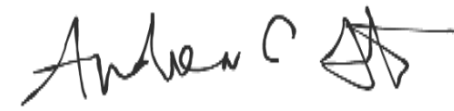
A handwritten signature in black ink, appearing to read "Andrew C. Pratt". The signature is fluid and cursive, with a large initial "A" and a stylized "P" at the end.

City of Milwaukee Historic Preservation

Copies to: Development Center, Ald. Pratt

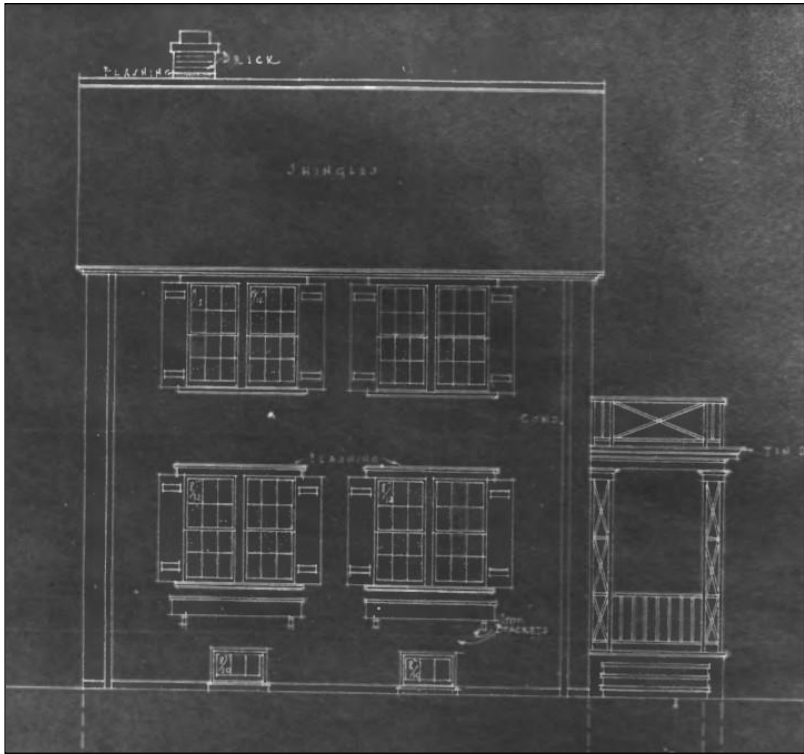

2465 W. Congress porch (Model 6G)

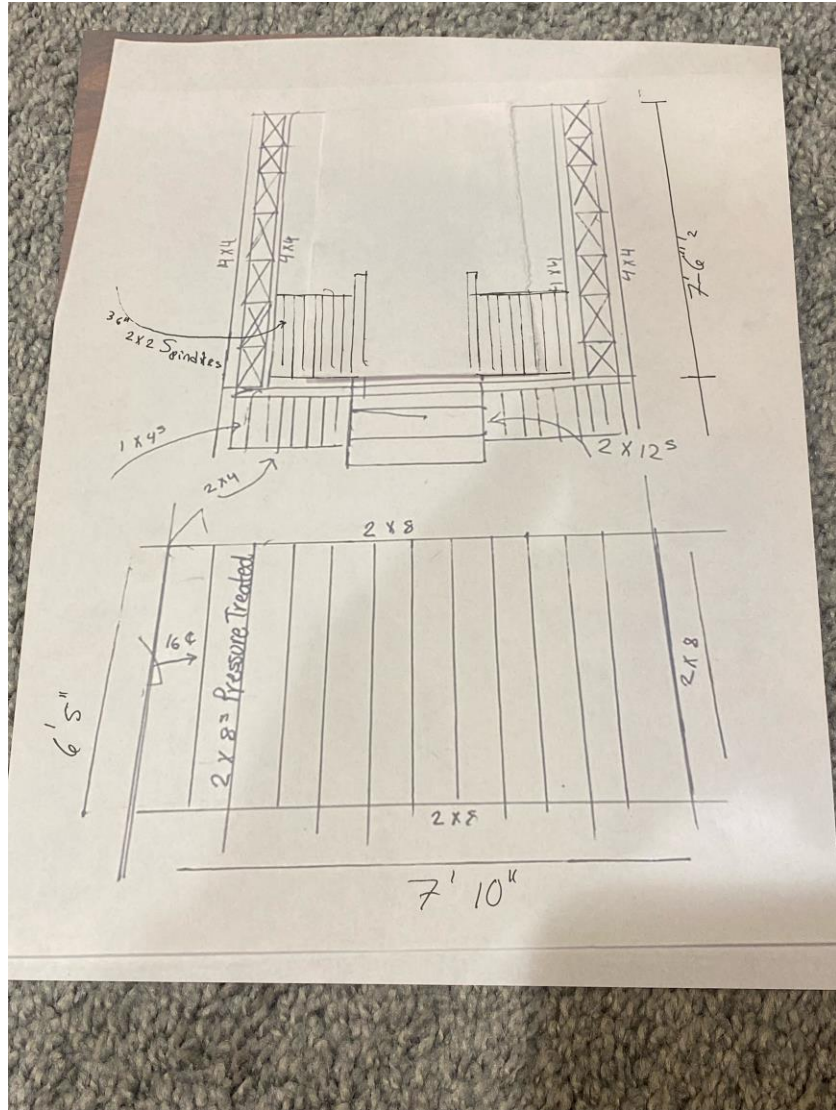

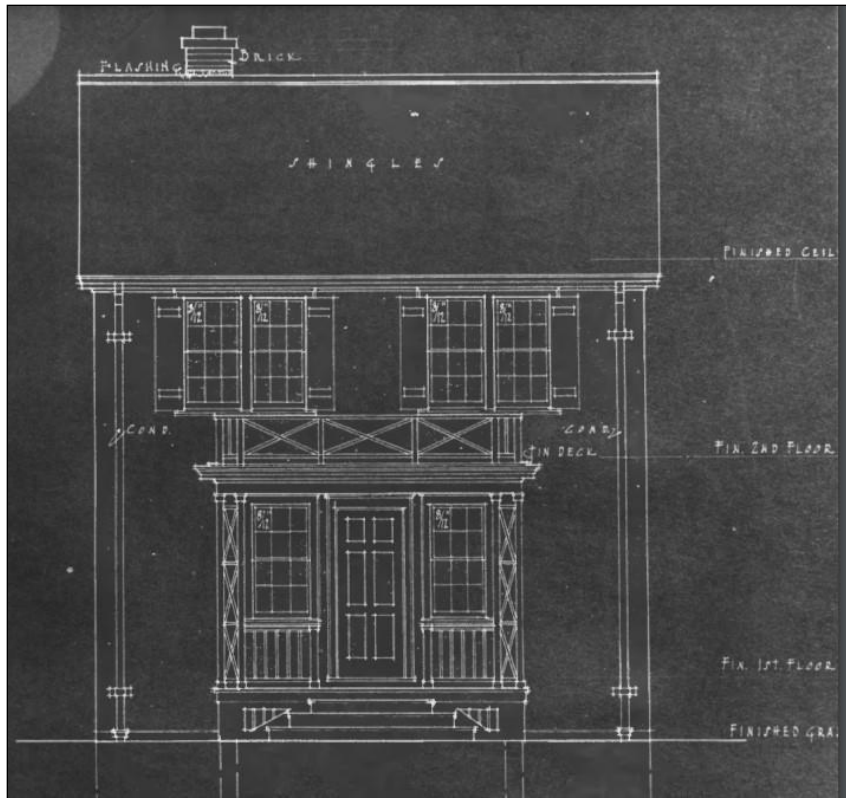

4384 N. 25<sup>th</sup> porch (Model 6B)

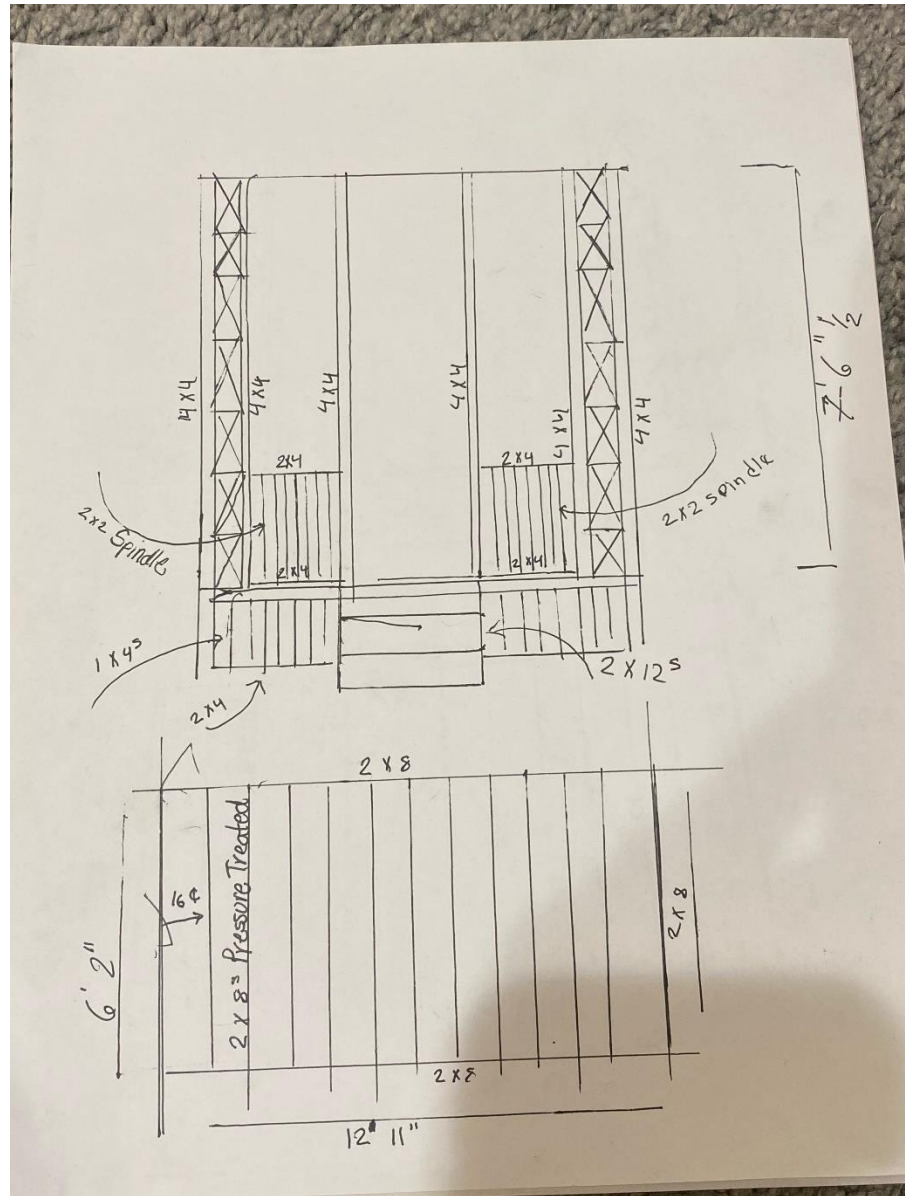

# Porches



## Basic Railing and Newel Post Design

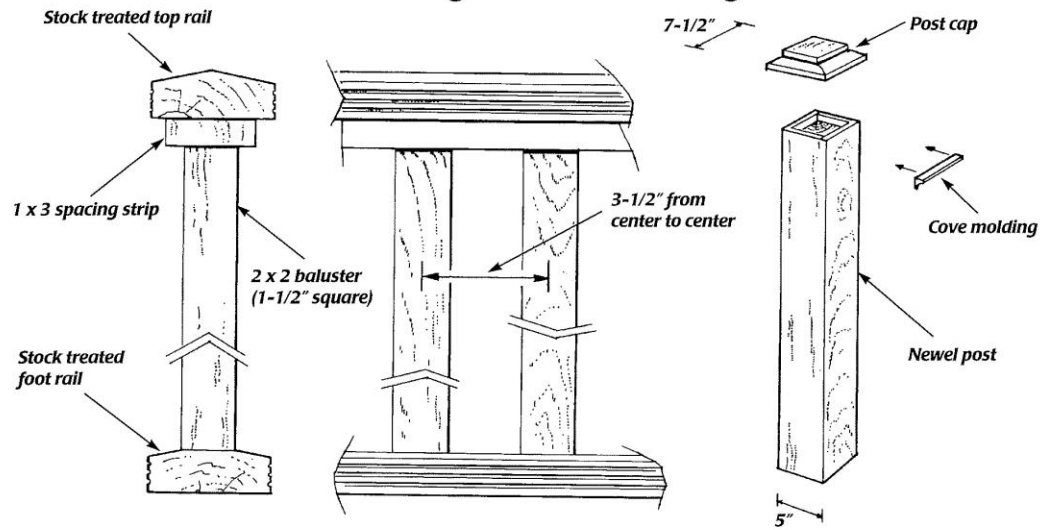

*The number of historic handrail and newel post designs is literally endless. The above designs are appropriate for many houses built before 1940 and would be approved by the Historic Preservation Commission for most homes.*

53

Porch top rail must have profile less than 2x4"