



LIVING WITH HISTORY

Certificate of Appropriateness

Milwaukee Historic Preservation Commission/200 E. Wells Street/Milwaukee, WI 53202/phone 414-286-5712/fax 414-286-3004

Property 1843 N 2nd St. Brewer's Hill
Description of work Replace the decking, newel posts, railing, skirting, and skirting frame on the front porch.
Date issued 6/24/2019 PTS ID 114779 COA: new porch

In accordance with the provisions of Section 320-21 (11) and (12) of the Milwaukee Code of Ordinances, the Milwaukee Historic Preservation Commission has issued a certificate of appropriateness for the work listed above. The work was found to be consistent with preservation guidelines. The following conditions apply to this certificate of appropriateness:

Pressure-treated wood may not be used in visible locations. It can be obscured by wrapping or used structurally where it is hidden by skirting.

All work must be done in a craftsman-like manner, and must be completed within one year of the date this certificate was issued. Staff must approve any changes or additions to this certificate before work begins. Work that is not completed in accordance with this certificate may be subject to correction orders or citations. If you require technical assistance, please contact Historic Preservation staff as follows: Phone: (414) 286-5712 E-mail: hpc@milwaukee.gov.

If permits are required, you are responsible for obtaining them from the Milwaukee Development Center. If you have questions about permit requirements, please consult the Development Center's web site, www.milwaukee.gov/build, or call (414) 286-8210.

City of Milwaukee Historic Preservation Staff

Copies to: Development Center, Ald. Milele A. Coggs



front of house with existing porch which will be repaired (note: at the time of this photo, railings were removed to complete painting of trim and columns)



existing porch to be repaired (prior to house painting)

Porch construction plan with materials and dimensions

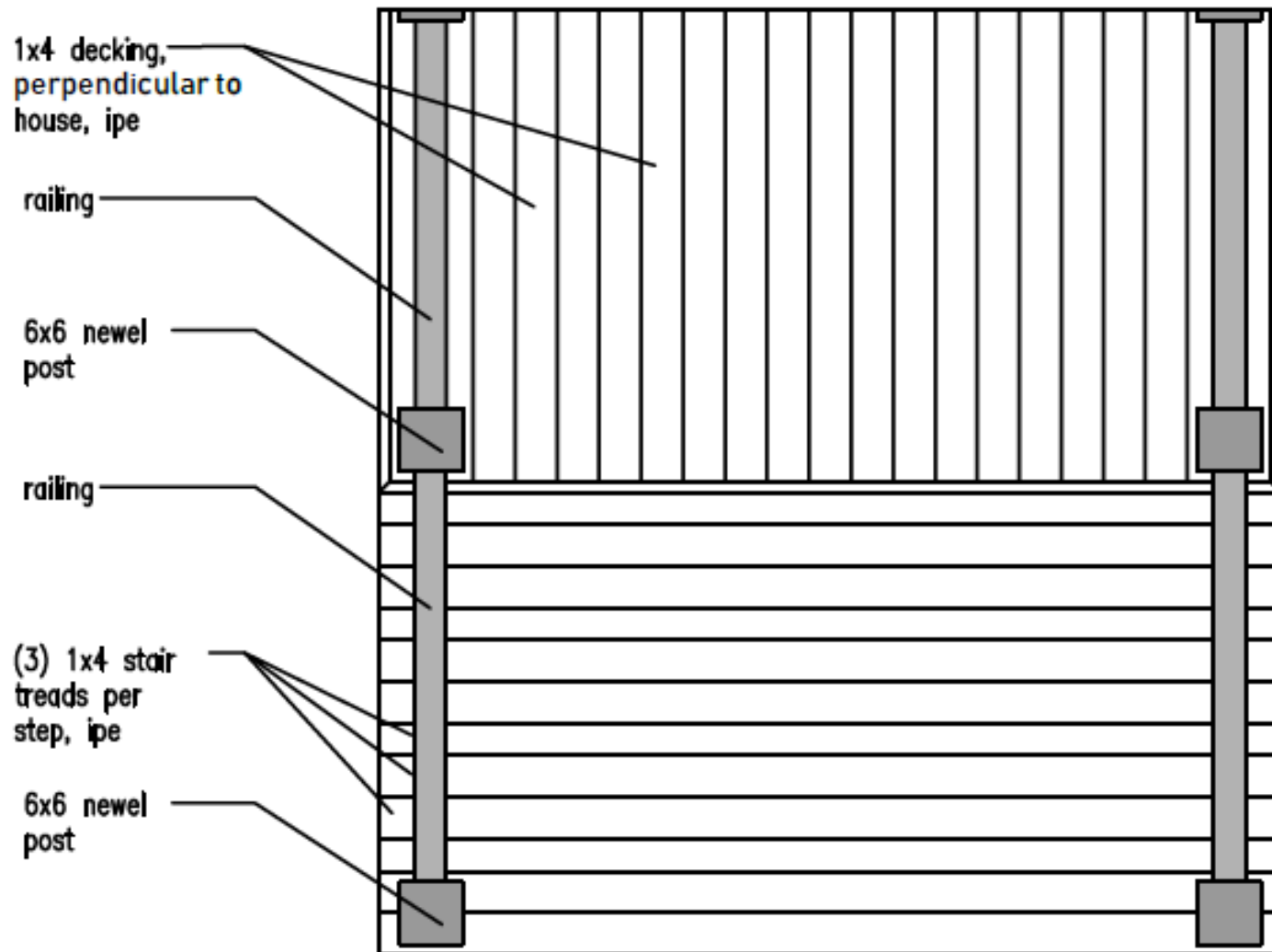

Porch Construction Examples to be Followed

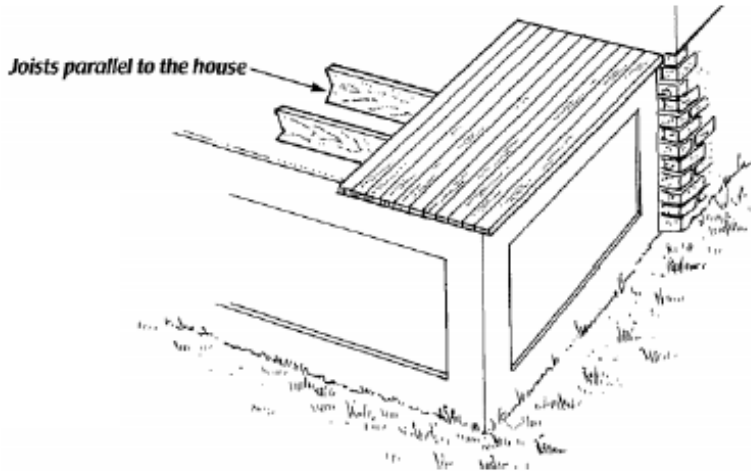

Existing joists parallel to house to remain.

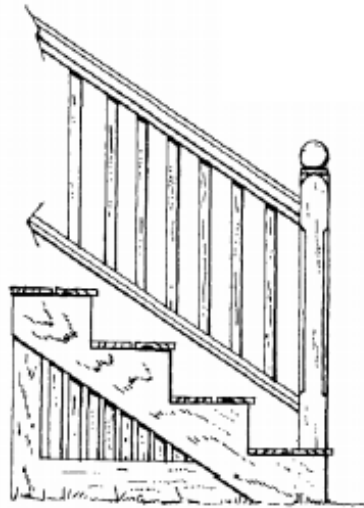

Existing stringers and footing to remain.

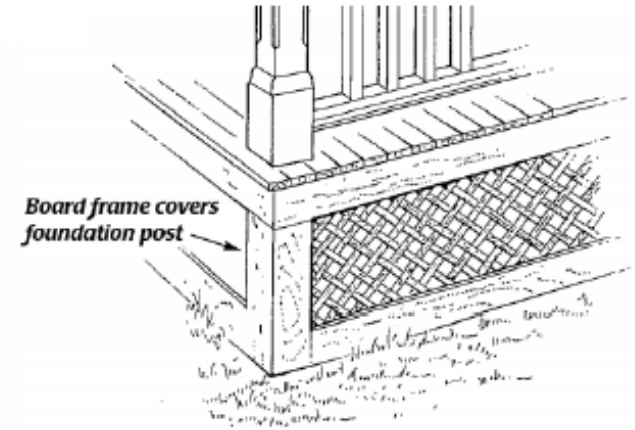

Porch Skirting and framing to be installed as required, see attached images.

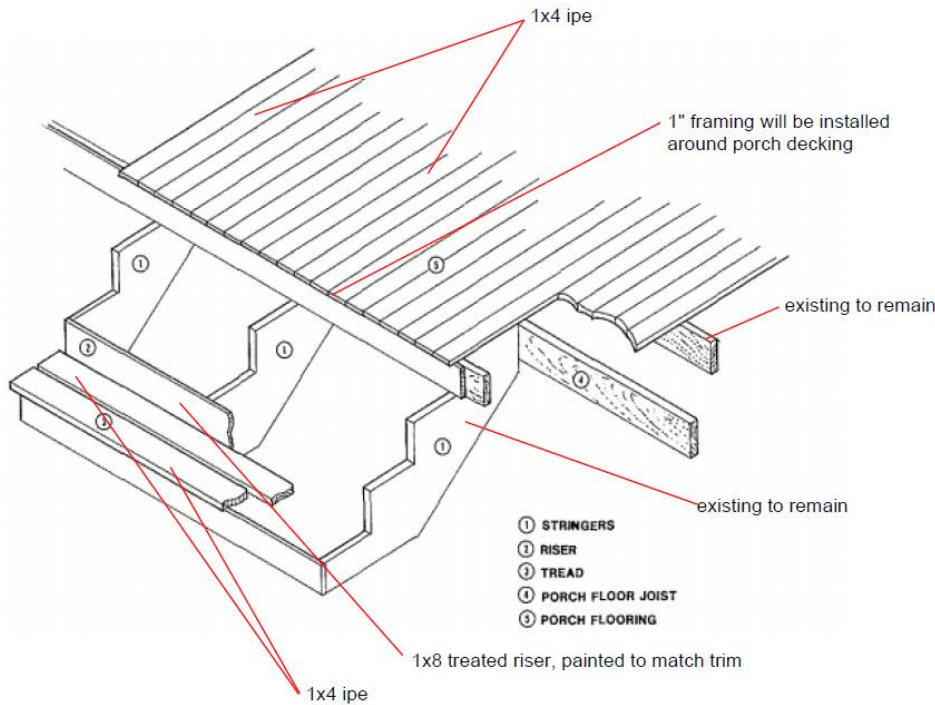

Porch construction examples to be followed with materials and dimensions

Porch construction examples to be followed – examples from Brewer’s Hill Neighborhood. **Thicker balusters than those used at left are required.**



railing style, 36" height from top of decking, maximum 3.5" spacing between balusters



porch skirting style example, framing typical

ipe decking, perpendicular to house

ipe treads

painted treated lumber riser

Porch construction examples to be followed – examples from Brewer’s Hill Neighborhood

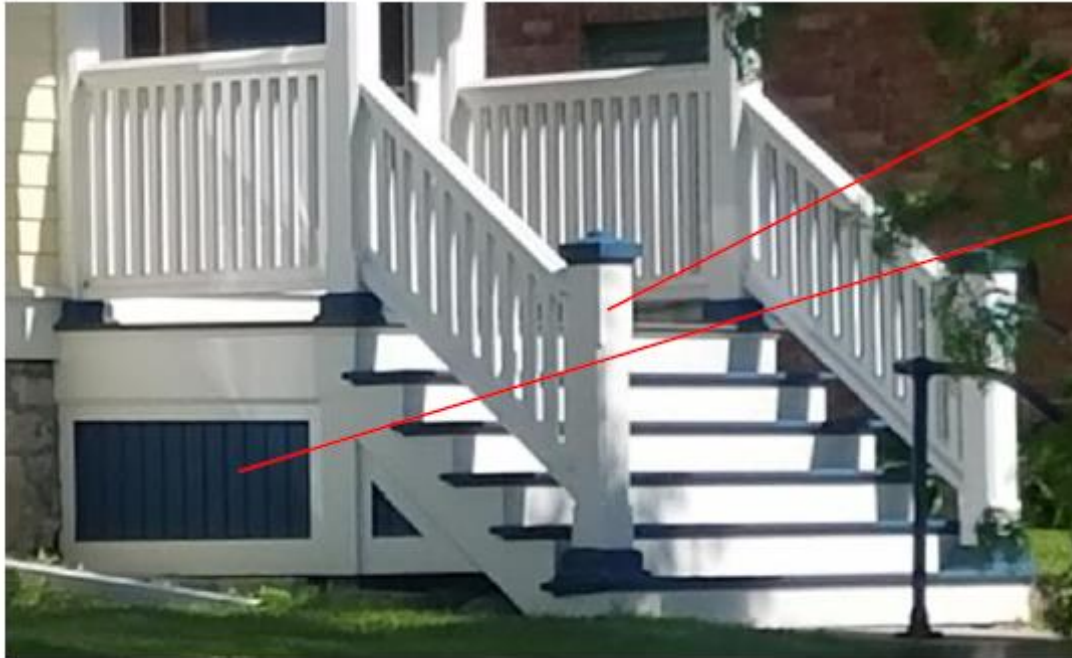

newel post

alternative skirting and framing design