



CERTIFICATE OF APPROPRIATENESS APPLICATION FORM
Incomplete applications will not be processed for Commission review.
Please print legibly.

1. HISTORIC NAME OF PROPERTY OR HISTORIC DISTRICT: (if known)

Joseph E. Dixon House (North Point North Historic District)

ADDRESS OF PROPERTY:

2723 E Bradford Avenue, Milwaukee, WI, 53211

2. NAME AND ADDRESS OF OWNER:

Name(s): Jason and Meegan Schultz

Address: 2723 E Bradford Avenue

City: Milwaukee

State: WI

ZIP: 53211

Email: 2723schultz@gmail.com

Telephone number (area code & number) Daytime: 4143365453

Evening: 4143365453

3. APPLICANT, AGENT OR CONTRACTOR: (if different from owner)

Name(s):

Address:

City:

State:

ZIP Code:

Email:

Telephone number (area code & number) Daytime:

Evening:

4. ATTACHMENTS: (Because projects can vary in size and scope, please call the HPC Office at 414-286-5712 for submittal requirements)

A. REQUIRED FOR MAJOR PROJECTS:

Photographs of affected areas & all sides of the building (annotated photos recommended)

Sketches and Elevation Drawings (1 full size and 1 reduced to 11" x 17" or 8 1/2" x 11")
A digital copy of the photos and drawings is also requested.

Material and Design Specifications (see next page)

B. NEW CONSTRUCTION ALSO REQUIRES:

Floor Plans (1 full size and 1 reduced to a maximum of 11" x 17")

Site Plan showing location of project and adjoining structures and fences

PLEASE NOTE: YOUR APPLICATION CANNOT BE PROCESSED UNLESS BOTH PAGES OF THIS FORM ARE PROPERLY COMPLETED AND SIGNED.

5. DESCRIPTION OF PROJECT:

Tell us what you want to do. Describe all proposed work including materials, design, and dimensions. Additional pages may be attached.

1) Replace second floor, rear steel door with single pane, wood frame glass door that is consistent with first floor, rear doors. Also add single pane storm door to protect second floor rear door. Replacement door and storm door specifications attached.

2) Replace first floor, powder room window with replacement window. Replacement window will specification attached. (existing, exterior storm window will remain intact)

3) Replacement concrete driveway in same length and width as existing.

6. SIGNATURE OF APPLICANT:

Signature
Jason Scholtz

5/24/2018

Date

Please print or type name

This form and all supporting documentation **MUST** arrive by 12:00 noon on the deadline date established to be considered at the next Historic Preservation Commission Meeting. Any information not provided to staff in advance of the meeting will not be considered by the Commission during their deliberation. Please call if you have any questions and staff will assist you.

Hand Deliver or Mail Form to:
Historic Preservation Commission
City Clerk's Office
200 E. Wells St. Room B-4
Milwaukee, WI 53202

PHONE: (414) 286-5722

hpc@milwaukee.gov

www.milwaukee.gov/hpc

Or click the **SUBMIT** button to automatically email this form for submission.

SUBMIT

R.Q.

R.Q. ENTERPRISES LTD.
N51 W16634 FAIR OAK PARKWAY
MENOMONEE FALLS, WISCONSIN 53051
Phone 262-373-0730

(Second Floor Door
replacement)

May 3, 2018

JASON & MEGAN SCHULTZ
2723 EAST BRADFORD STREET
MILWAUKEE, WISCONSIN 53211

Dear Jason & Megan,

This proposal will detail the work needed to replace the prime and combination doors of the exterior entry door of the master bedroom. The new interior prime door will swing in, the same direction as the present door. The exterior combination door will swing open to the East direction. I will supply and install Marvin Brand doors, to match the lower level kitchen entry doors. The new doors will be primed and painted by me, with your supplied paint.

The existing interior door mouldings will be removed to be reinstalled. The existing door and frame will be removed and disposed of. I will rebuild and flash the existing threshold area to reduce air infiltration and protect against water leakage. The new prime door frame will be installed and secured. I will foam the gaps around the new door frame and the home's framing, then install new exterior door frame mouldings. The interior door mouldings will be installed and sealed in place. The new prime, full view door will be installed with new brushed nickel, adjustable hinges. A brushed nickel lockset and double-cylinder deadbolt will be installed for security.

A new Marvin Brand, wood, full view combination door will then be installed onto the exterior of the new prime door frame. This new door will feature both a screen panel for summer air and a winter glass panel to keep out the winter air. I will install a secondary, limiting chain at the top of the door, to reduce the possibility of the wind grabbing the storm door and wildly swinging it open. All new doors and mouldings will be finish painted with your finish paint. The total investment for this work, as described, will come to \$ 5,280.00, complete. If you have any questions, please ask and I will try to answer them for you.

Sincerely



Robert J. Quint, President

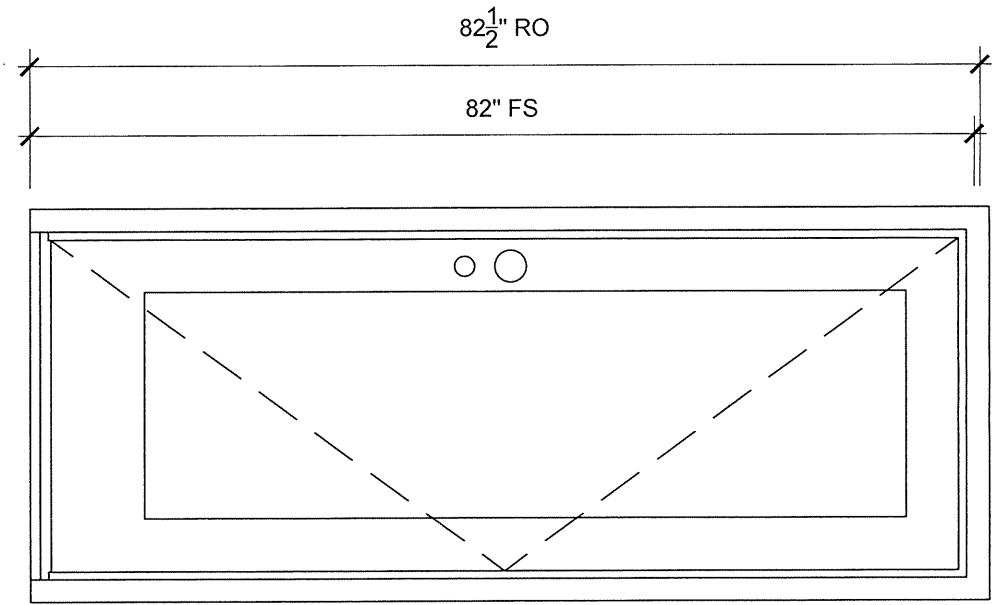
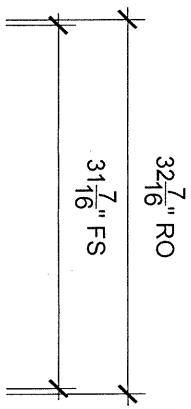

*Schematic -
Second floor
replacement door*

WOOD ULTIMATE INSWING FRENCH DOOR
SECTION DETAILS - OPERATING

4 9/16"

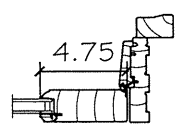

HEAD

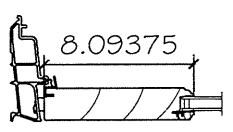

SILL

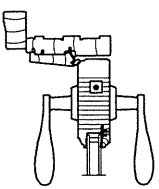

JAMBS

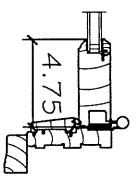

X - RH

(First floor replacement window)

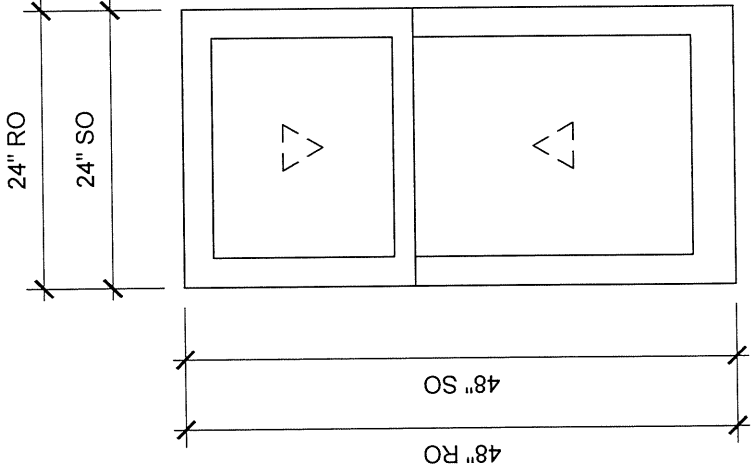

DOUBLE HUNG

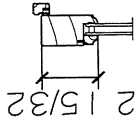

HEAD

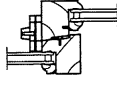

CHECKRAIL

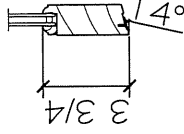

SILL

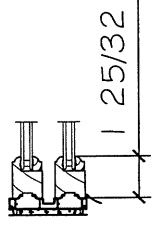

JAMB



PROJ/JOB: RQ ENTERPRISES / MARVIN WOOD DOOR
DIST/DEALER: LISBON STORM SCREEN & DOOR
DRAWN: TOREY
QUOTE#: XUYLDKU

PK VER: 0002.20.00

CREATED: 05/01/2018

REVISION:

SHEET
2
OF
2

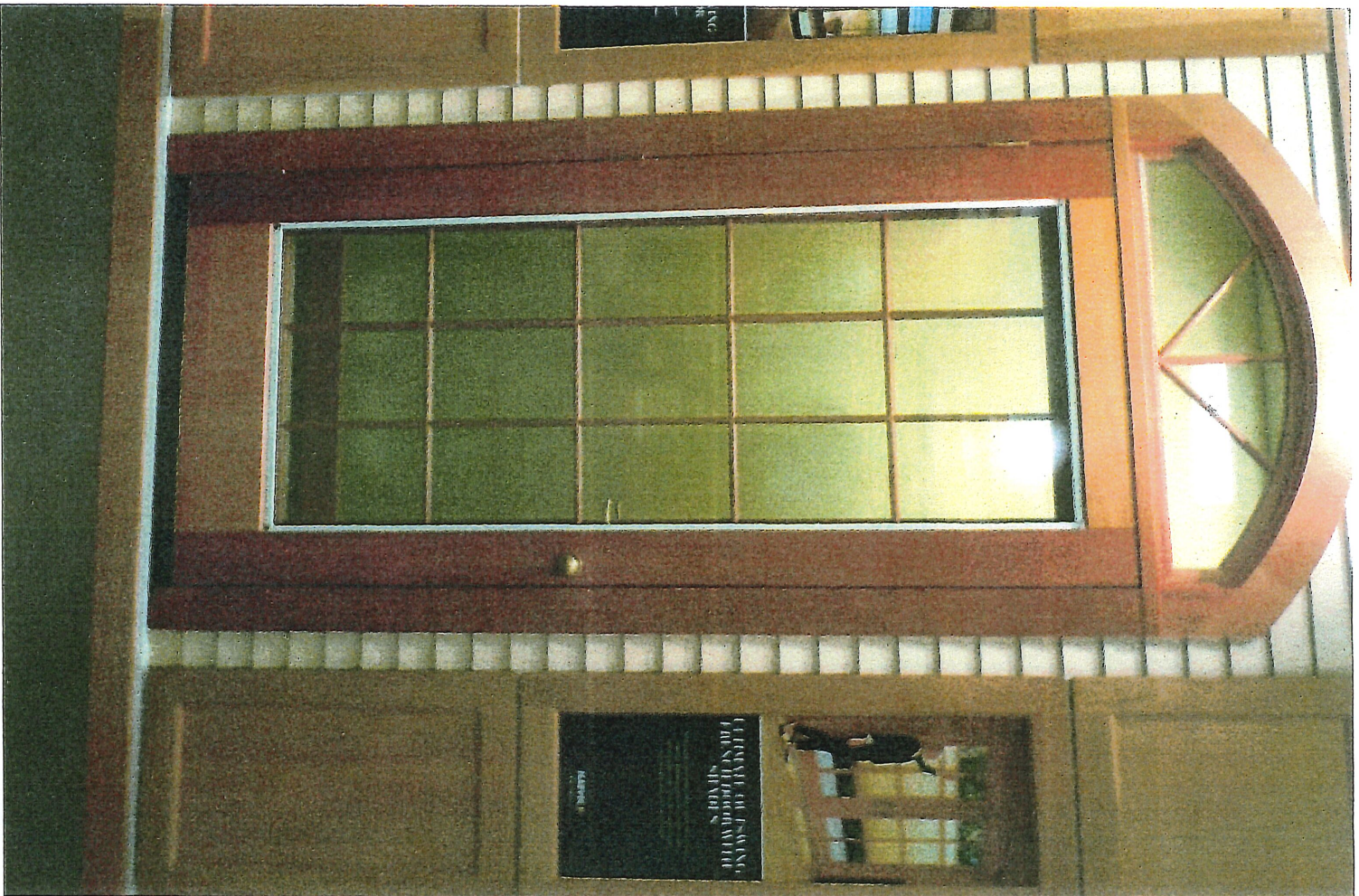

Storm door picture (will
be painted white)

(Door only -
upper window
will not be
part of remodel)



(Door only -
upper window
not part of
remodel)

Feedback

Was this article helpful?

Yes

No

Storm door picture
(will be painted white)

R.Q.

R.Q. ENTERPRISES LTD.
NS1 W16634 FAIR OAK PARKWAY
MENOMONEE FALLS, WISCONSIN 53051
Phone 262-373-0730

(First Floor powder
room window
replacement)

July 26, 2017

JASON & MEGAN SCHULTZ
2723 EAST BRADFORD DRIVE
MILWAUKEE, WISCONSIN 53211

Dear Jason & Megan,

This proposal will detail the work needed to replace the first floor powder room window. The existing main frame, wood trim and storm window will remain in place. I am offering two options in this proposal for the replacement of the old, inefficient sashes that exist. Both options will be made by Marvin Brand windows, with factory primed wood sashes and high efficiency privacy glazed insulated glass. And both options will use the privacy/frosted glazing to allow maximum light into the room, during the day. All debris generated by my work will be removed and disposed of safely. The new window sashes will be painted with your supplied paint, prior to installation.

The first option is to install a custom-made, Tilt-Pak sash/replacement kit, with two, Cottage style operating wood sashes. The existing weights and pulleys will be removed and the cavities will then be filled with insulating foam. New side-balances will be installed and the existing interior wood stops will be re-installed. The new side-balances will allow both sashes to tilt in for easy cleaning. The investment for this option comes to \$ 1,142.00, complete.

The second option is to install a single lite, wood framed insulated glass stationary window sash into this opening. This option eliminates the two operating sashes, but will use the same glass as the tilt-pak unit. I will need to make and install custom stops to secure this window, but the interior look will remain the same. The ropes and pulleys will again be removed and the side cavities will be filled with insulating foam. The investment for this option as described will come to \$ 1,778.00, complete. Please call with any questions that you may have and I will try to answer them for you. Thanks again for your consideration.

Sincerely,



Robert J. Quint, President

