

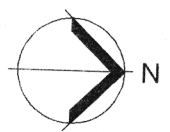



1 EAST ELEVATION
1/4" = 1'-0"



NOTES:
 SCOPE OF WORK: REPAIR OF FIRE ESCAPE PER ZERRECON REPORT DATED 6/15/21
 ALL WELDS TO FOLLOW AWS D1.1 SERIES ROD
 ALL NEW STAIR TREADS ATTACHED TO 1/2" DIAMETER HARDWARE UP BY 1/4" LONG WELDS (2 PER SIDE)
 THE ENTIRE FIRE ESCAPE SHALL HAVE THE RUST REMOVED AND THE METAL REPAINTED.
 ALL NEW MATERIAL TO BE A325 STEEL OR BOLT

 HATCHED AREAS DEMOTE PAST REPAIRS BY OTHERS
 HATCHED AREAS ENGINE MATERIAL TO BE ADDED BY THIS REPAIR

WELD 1/2" X 1/4" X 3/16" ANGLE TO PIVOT ASSEMBLY VERIFY ANGLE IRON SIDE AT THE START OF THE REPAIRS

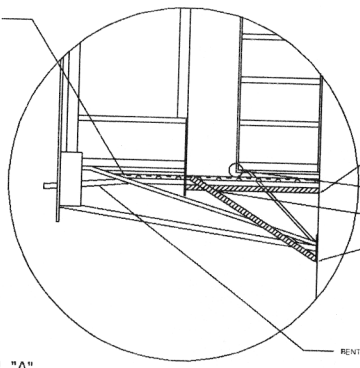

3 DETAIL "A"
1/4" = 1'-0"

2 SOUTH ELEVATION
1/4" = 1'-0"

 Professional Engineering Services
 34206 Davies Drive
 Oconomowoc, WI 53066
 414-771-7140
 www.zerrecon.com
 Matt Soiney@Zerrecon.com

| No. | Revision/Issue | Date |
|-----|----------------|--------|
| 1 | RELEASE | 3/2/22 |

Drawn By: MJS
 Checked By:

Project Name and Location:
 REPAIR TO FIRE ESCAPE
 MILWAUKEE, WI

Drawing No. 542028-4
 Date 2/4/22
 Scale 1/1