



MILWAUKEE
**HISTORIC
 PRESERVATION
 COMMISSION**

LIVING WITH HISTORY

Certificate of Appropriateness

Milwaukee Historic Preservation Commission/200 E. Wells Street/Milwaukee, WI 53202/phone 414-286-5712/fax 414-286-3004

Property

3316 W. MC KINLEY BL., Cold Spring Park Historic District, Will Sherard, Owner

Description of work

Remove existing porch deck, columns, railings and guardrails. Install new porch deck, handrails, guardrails posts and skirting.

Date issued

6/27/2011

PTS ID 73501 COA, porch posts, railings, guardrails, deck and skirting.

In accordance with the provisions of Section 308-81(9) of the Milwaukee Code of Ordinances, the Milwaukee Historic Preservation Commission has issued a certificate of appropriateness for the work listed above. The work was found to be consistent with preservation guidelines. The following conditions apply to this certificate of appropriateness:

All work will be done according to attached photos, drawings and specifications. All finish exterior wood will be painted upon completion. Please note that research has shown that when new, bare wood is exposed to the elements for a period of only a week or two, the life the paint job applied over it is likely to be decreased. Finish wood will be free of knots. Balusters to be 2.x 2 and spaced 1-1/4" apart. Box posts for the porch will be 7-1/2 inches square. Porch deck must be center-match (also known as tongue-and-groove) material. Spaced deck boards are not permitted. Slats or lattice may be used for the skirting (see attached drawings). All work must be done in a craftsman-like manner, and must be completed within one year of the date this certificate was issued. Staff must approve any changes or additions to this certificate before work begins. Work that is not completed in accordance with this certificate may be subject to correction orders or citations. If you require technical assistance, please contact Paul Jakubovich of the Historic Preservation staff as follows: Phone: (414) 286-5712 Fax: (414) 286-3004 E-mail: pjakub@milwaukee.gov. If permits are required, you are responsible for obtaining them from the Milwaukee Development Center. If you have questions about permit requirements, please consult the Development Center's web site, www.mkedcd.org/build, or call (414) 286-8210.

Paul Jakubovich

City of Milwaukee Historic Preservation

Copies to: Development Center, Ald. Robert Bauman, Inspector Joel Walloch (286-8160)

No existing trim can be permanently removed.

Box posts, 7-1/2" square (four total) to be installed

Existing deck boards to be removed

New handrails, guardrails and skirting to be installed

3316 W. McKinley Blvd.

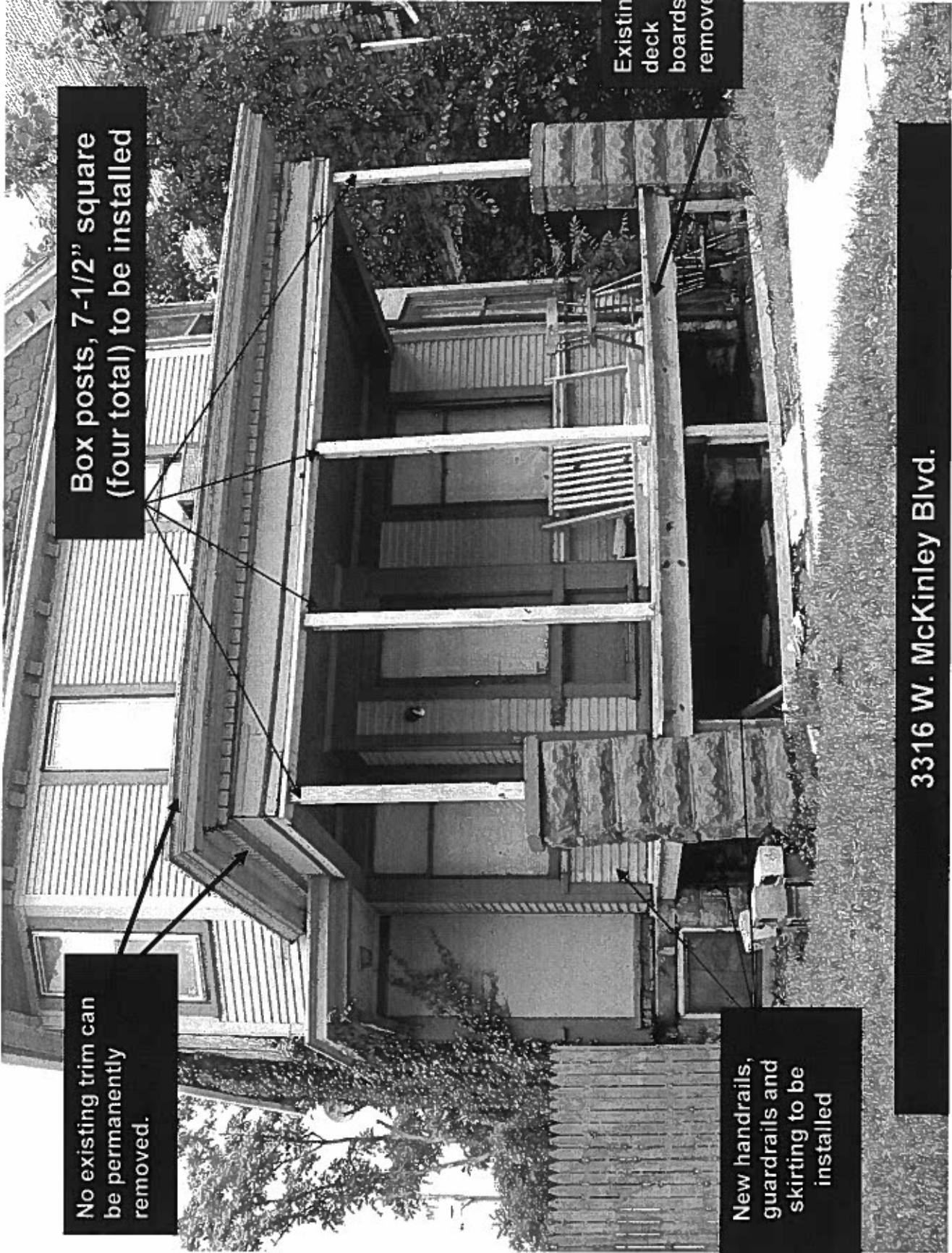

If additional 2 x material (SEEN HERE) is used to reinforced the cornice, then it must be covered with 1x finish lumber beginning from the astragal

Astragal

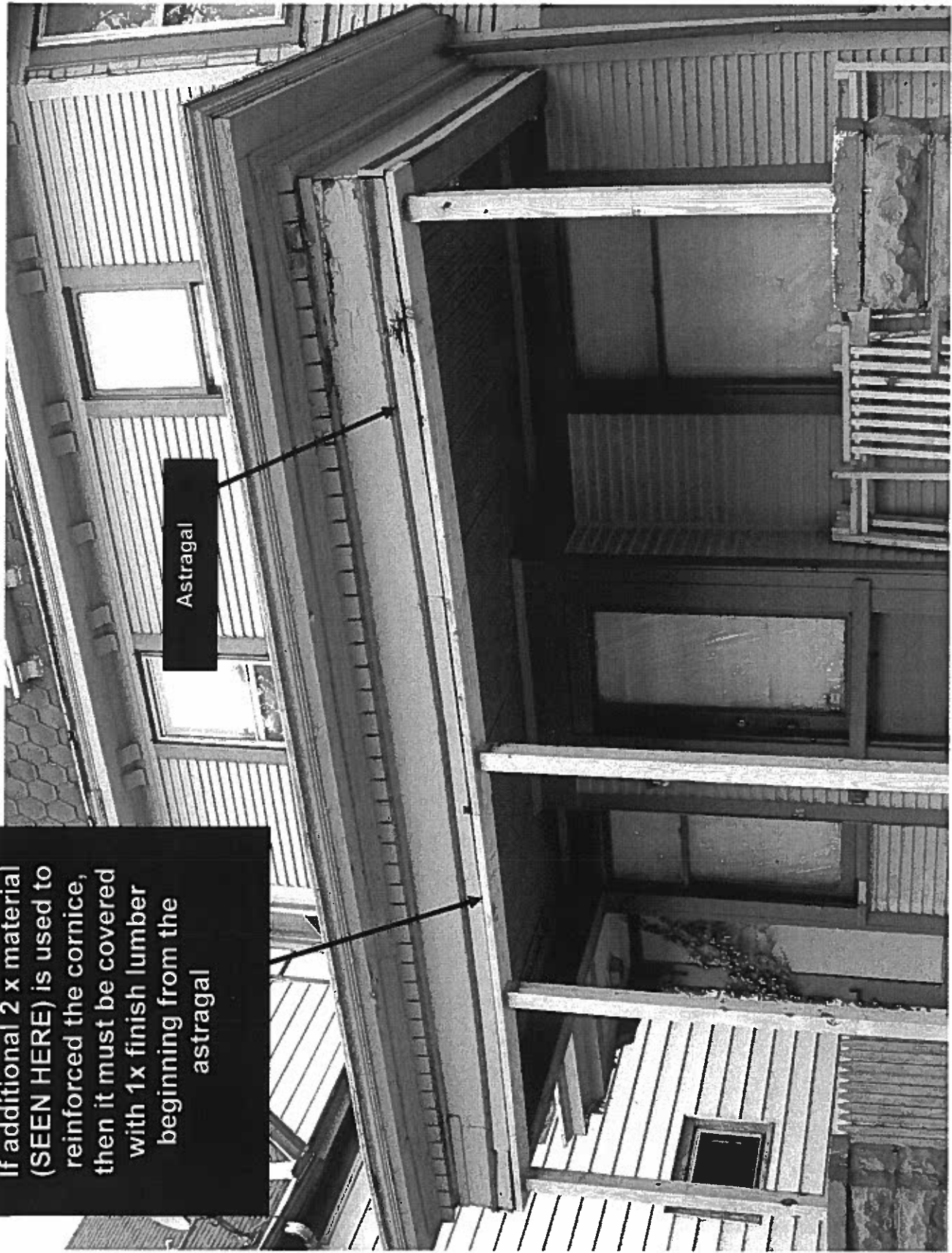

Porches



Traditional Porch Floors

Porch floors should be constructed of center matched or tongue-and-groove wooden flooring, which typically measures 2-1/4" wide by 3/4" thick. This flooring gives the porch a fine finished appearance. The joists, which are the structural framing members to which the flooring is attached, should always be run parallel to the house so that the floor boards can be installed perpendicular to the house. The porch floor should also be very slightly pitched away from the house. This method of construction for a porch floor will shed water and make the porch last longer.

Joists parallel to the house

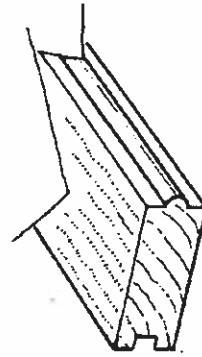

Center match or tongue-and-groove flooring

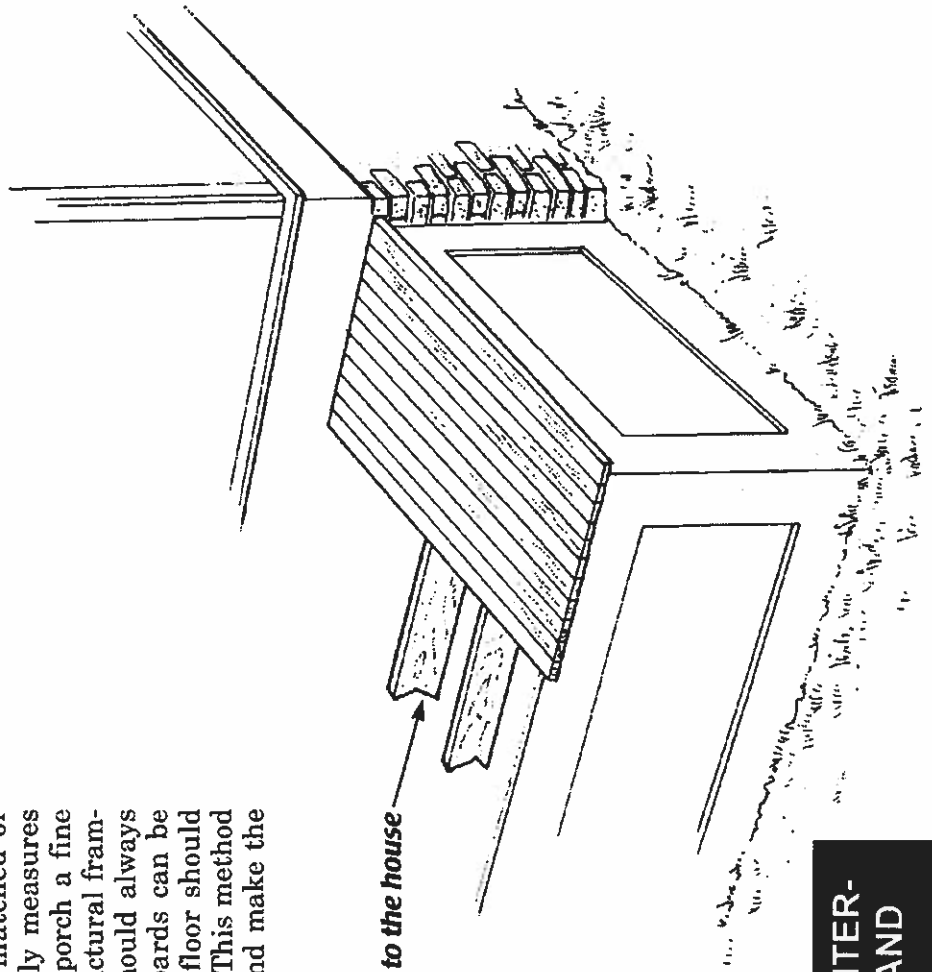

PORCH DECK MUST BE MADE OF CENTER-MATCH, ALSO KNOWN AS TONGUE AND GROOVE MATERIAL

Please note the design for the optional 5-1/2" square box post and top elsewhere on this certificate.

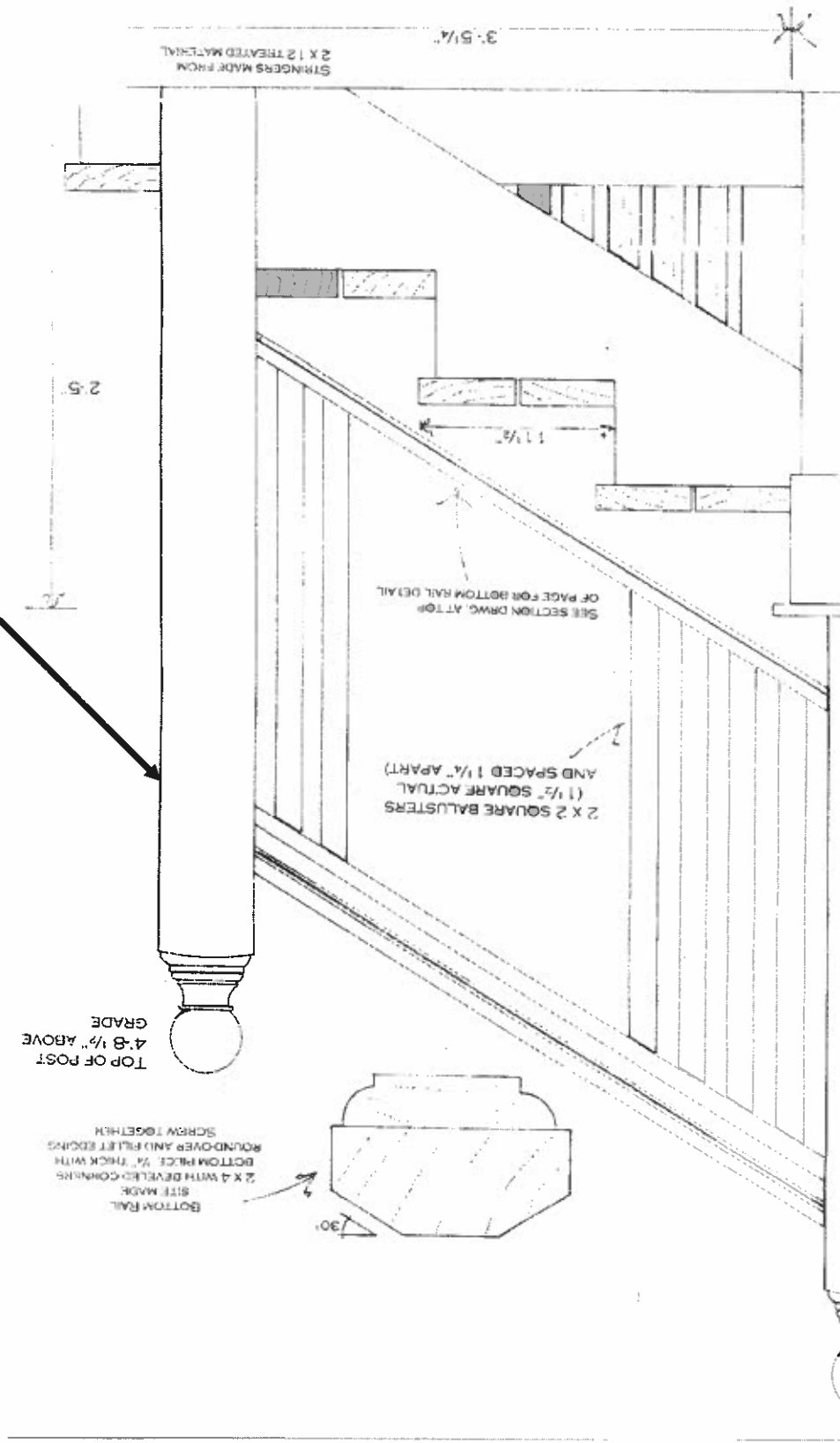

Porch railings and guardrails to be constructed according to this plan. Slats in skirting are 1-3/4" wide and spaced 3/4" apart. As an alternate to the vertical slats, a skirting infill of lattice may be substituted. 2 x 2 square balusters are spaced 1-1/4" apart

HANDRAIL ON STEPS
36" ABOVE NOSING
2 X 2 SQUARE BALUST
(1 1/2" SQUARE ACTU.
AND SPACED 1 1/4" APART)

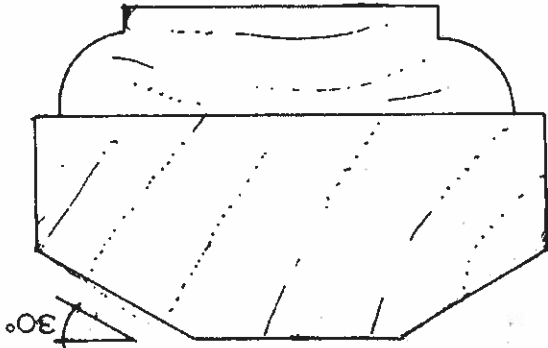
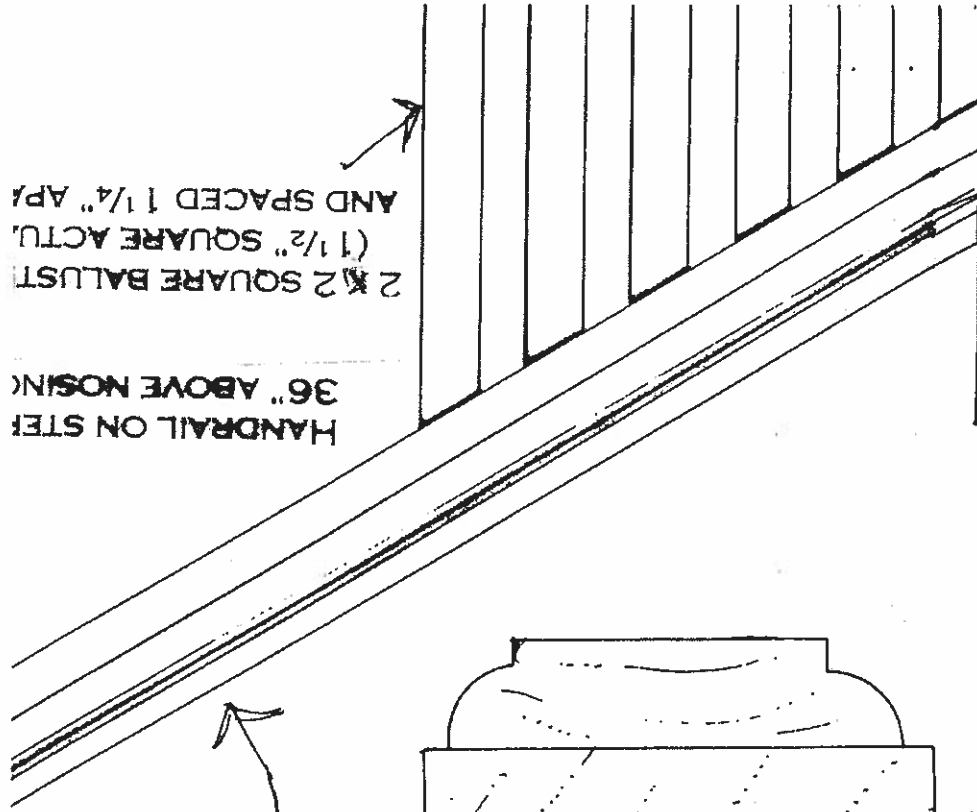

FROM RAIL
THE MADE
BEVELED CORNERS
3/4" THICK WITH
AND FILLET EDGING
W TO
ST
OVE

GRASPABLE HANDRA
CROWN SPECIALTY MOULD
#HR-548
WWW.CROWN.SPECIALTY.MOULD
608-290-1338
MILTON, WI

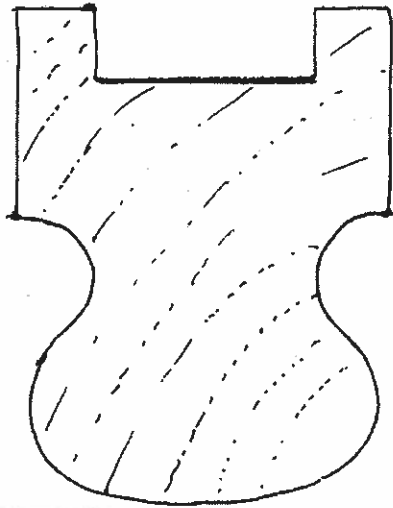

Section off handrail and bottom rail for porch. Bottom rail made from a 2x4 (clear) stock, beveled 30 degrees at the corner. A 1 x 3 with round-over and fillet to be screwed to the bottom

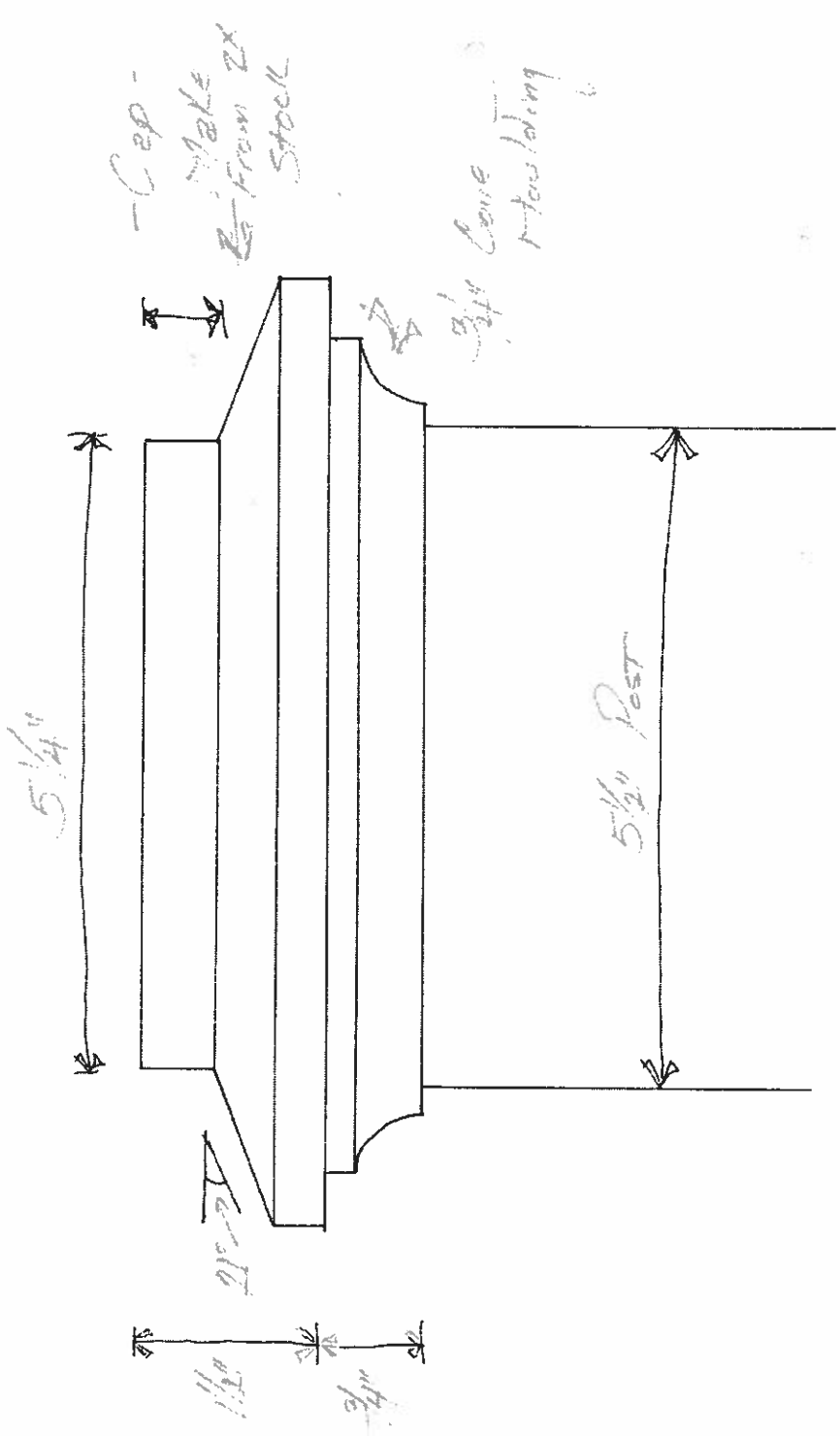

Optional square box post and top for newel posts on porch steps.

Porches



Porch Skirting

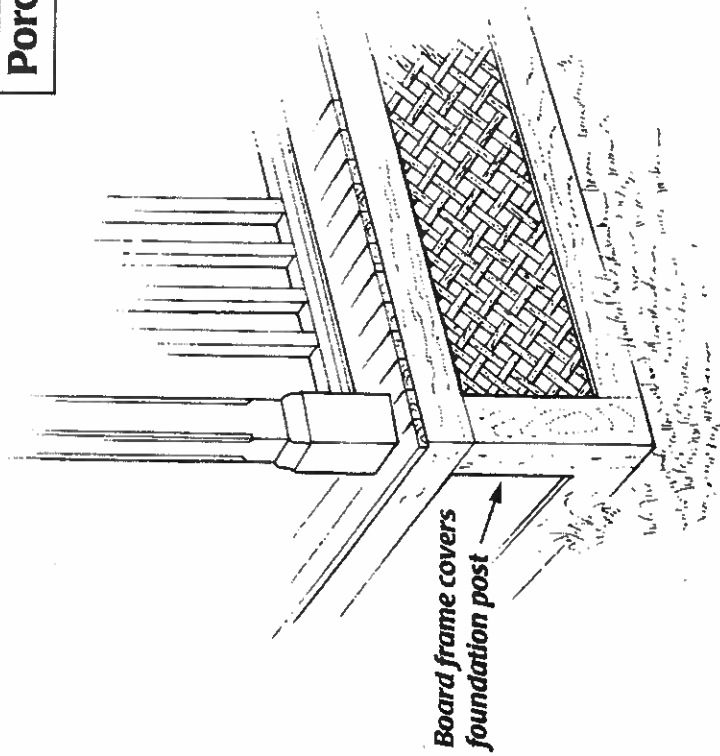

Skirting, such as this lattice panel, enclosed the area beneath the porch floor. It should always be installed with a continuous board frame around it that is wide enough to cover the rough framing lumber that supports the porch deck.

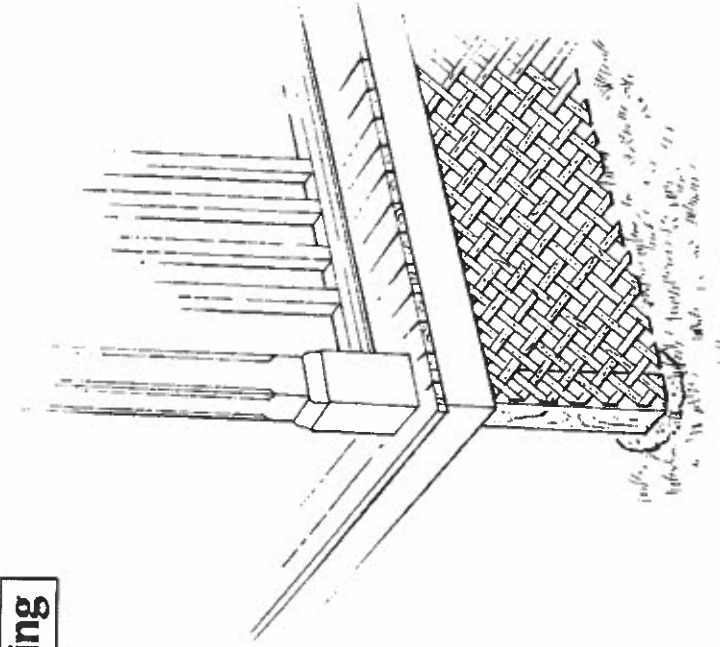

Do not install a lattice skirting without a frame around it. The rough framing lumber that supports the porch will show through and the raw edges of the lattice look unfinished.

Slats of 1-3/4" wide and spaced 3/4" apart may be substituted for the lattice work, but in either case a full frame surround as pictured at left is required.