

WESTLAWN GARDENS PHASE II

6331 W Silver Spring Dr
MILWAUKEE WI 53218

Owner
 Housing Authority of the City of Milwaukee
 414.286.3629

Architect
 Torti Gallas and Partners, Inc.
 1300 Spring Street, 4th Floor
 Silver Spring, MD 20910
 301.588.4800
 www.tortigallas.com

Local Architect
 Quorum Architects
 414.265.9265

Local Architect
 Eppstein Uhen Architects
 414.271.5350

Structural Engineer:
 R.A. Smith National
 262.317.3279

MEP Engineers:
 Thunderbird Engineering, Inc.
 414.352.2211

IBC Engineering Services, Inc.
 262.549.1190

Civil Engineer:
 R.A. Smith National
 262.522.4416

Landscape Architect:
 AVRES ASSOCIATES
 608.255.0800

Issue

No.	Date

Revisions

No.	Date

Landscape Plan

Date
 Principal In Charge
 D.W.
 Project Planner

Project Landscape Architect
 B.M.
 Project Manager
 B.M.
 Drawn
 B.M., R.S., S.K.
 Job No.
 27-1052
 Scale
 1" = 70'-0"

Drawing No.
L100

WESTLAWN GARDENS, PHASE II

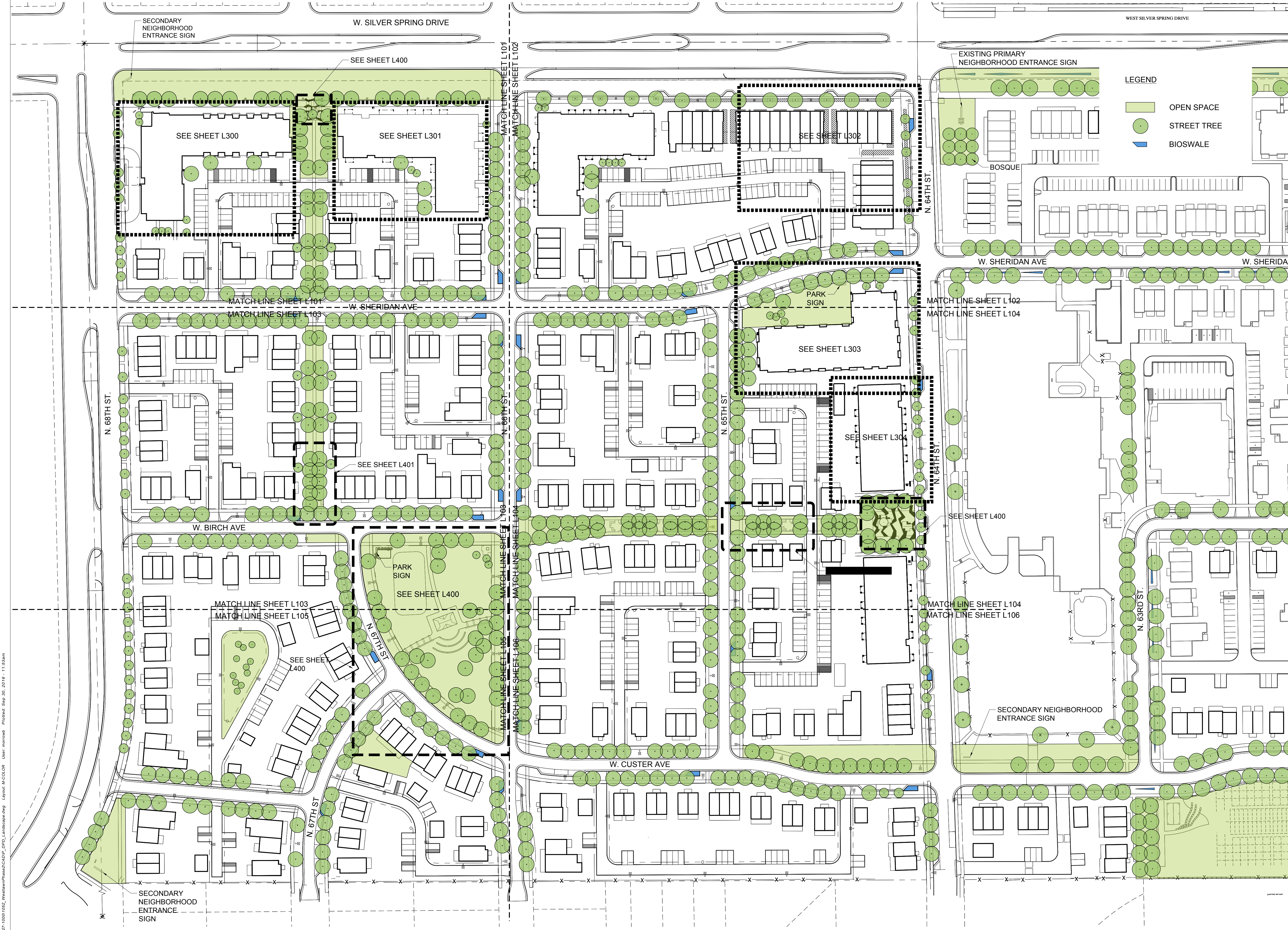

File: P:\27-1052\1052_WestlawnPhase2\ADP_DPD_Landscape.dwg Layer: MCOLOR User: mironowb Plotter: Sep 30, 2016 - 11:53am

WESTLAWN GARDENS PHASE II

6331 W Silver Spring Dr
MILWAUKEE WI 53218

Owner
 Housing Authority of the City of Milwaukee
 414.286.3629

Architect
 Torti Gallas and Partners, Inc.
 1300 Spring Street, 4th Floor
 Silver Spring, MD 20910
 301.588.4800
 www.tortigallas.com

Local Architect
 Quorum Architects
 414.265.9265

Local Architect
 Eppstein Uhen Architects
 414.271.5350

Structural Engineer:
 R.A. Smith National
 262.317.3279

MEP Engineers:
 Thunderbird Engineering, Inc.
 414.352.2211

IBC Engineering Services, Inc.
 262.549.1190

Civil Engineer:
 R.A. Smith National
 262.522.4416

Landscape Architect:
 AVRES ASSOCIATES
 608.255.0800

Issue
 No. _____ Date _____

Revisions
 No. _____ Date _____



Landscape Plan

Date _____
 Principal In Charge
 D.W.
 Project Planner
 Project Landscape Architect
 B.M.
 Project Manager
 B.M.
 Drawn
 B.M., R.S., S.K.
 Job No.
 27-1052
 Scale
 1" = 30'-0"

Drawing No.
L101

TORTI GALLAS AND PARTNERS, INC. WESTLAWN gardens, phase II

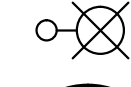
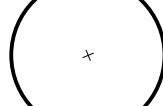
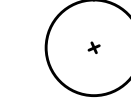
LEGEND

-  HARP LIGHT
-  ROADWAY LIGHT
-  CANOPY TREE
-  TREE UNDER POWER LINE
-  SPECIAL PAVEMENT

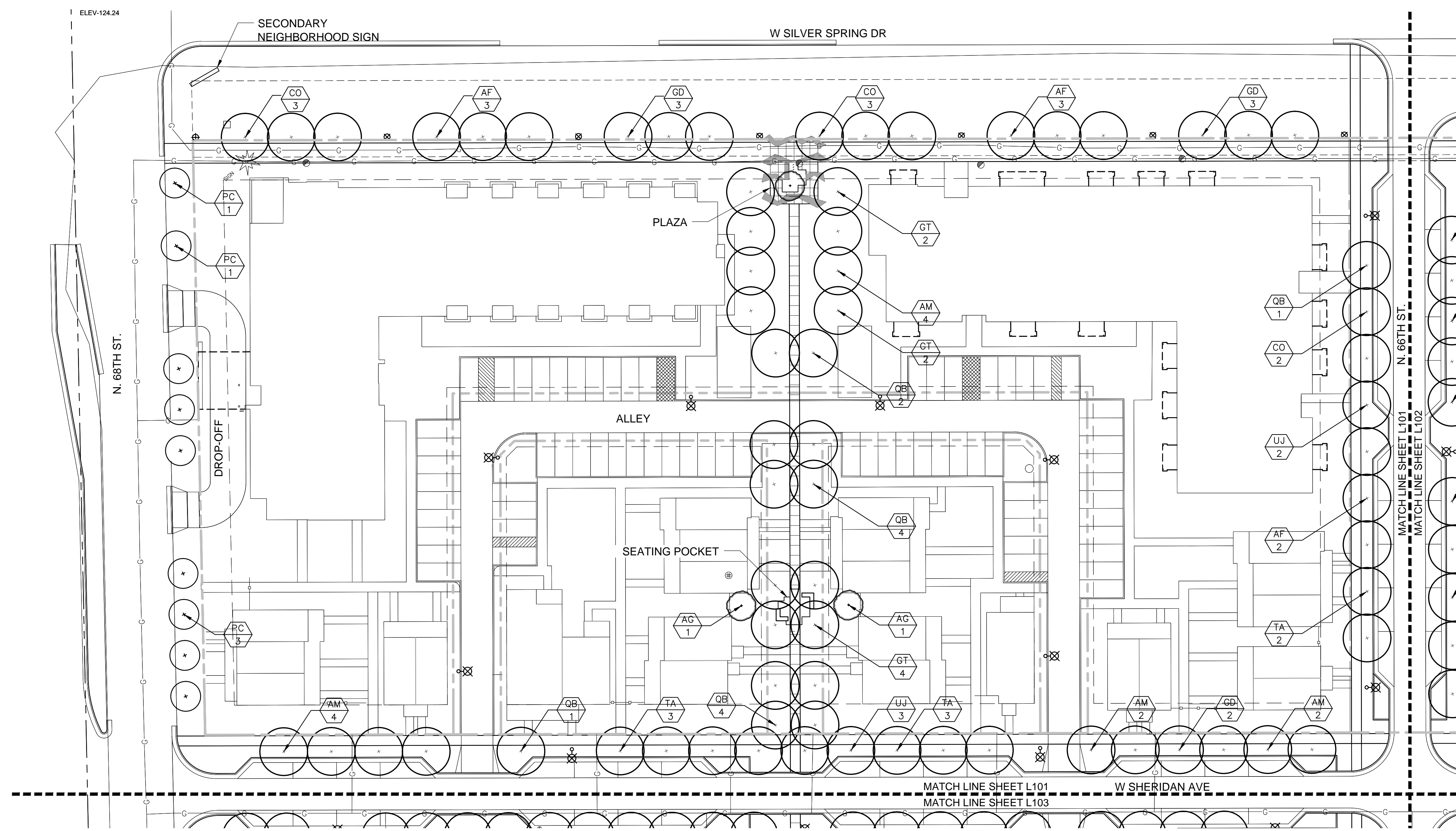

File: P:\27-1052_WestlawnPhase2\CD\VP_050_Landscape.dwg Layout: L101 User: stehr Plotted: Sep 30, 2016 - 11:50am

WESTLAWN GARDENS PHASE II

6331 W Silver Spring Dr
MILWAUKEE WI 53218

Owner
 Housing Authority of the City of Milwaukee
 414.286.3629

Architect
 Torti Gallas and Partners, Inc.
 1300 Spring Street, 4th Floor
 Silver Spring, MD 20910
 301.588.4800
 www.tortigallas.com

Local Architect
 Quorum Architects
 414.265.9265

Local Architect
 Eppstein Uhen Architects
 414.271.5350

Structural Engineer:
 R.A. Smith National
 262.317.3279

MEP Engineers:
 Thunderbird Engineering, Inc.
 414.352.2211

IBC Engineering Services, Inc.
 262.549.1190

Civil Engineer:
 R.A. Smith National
 262.522.4416

Landscape Architect:
 AVRES ASSOCIATES
 608.255.0800

Issue
 No. Date

Revisions
 No. Date

Landscape Plan





Date
 Friday, October 14, 2016
 Principal In Charge
 D.W.
 Project Planner
 Project Landscape Architect
 B.M.
 Project Manager
 B.M.
 Drawn
 B.M., R.S., S.K.
 Job No.
 13020.02
 Scale
 1" = 30'-0"

Drawing No.
L102

DESIGN DEVELOPMENT SET

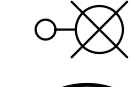
TORTI GALLAS AND PARTNERS, INC. VICTORY MANOR AT THE WESTLAWN GARDENS

LEGEND

-  HARP LIGHT
-  ROADWAY LIGHT
-  CANOPY TREE
-  TREE UNDER POWER LINE
-  SPECIAL PAVEMENT

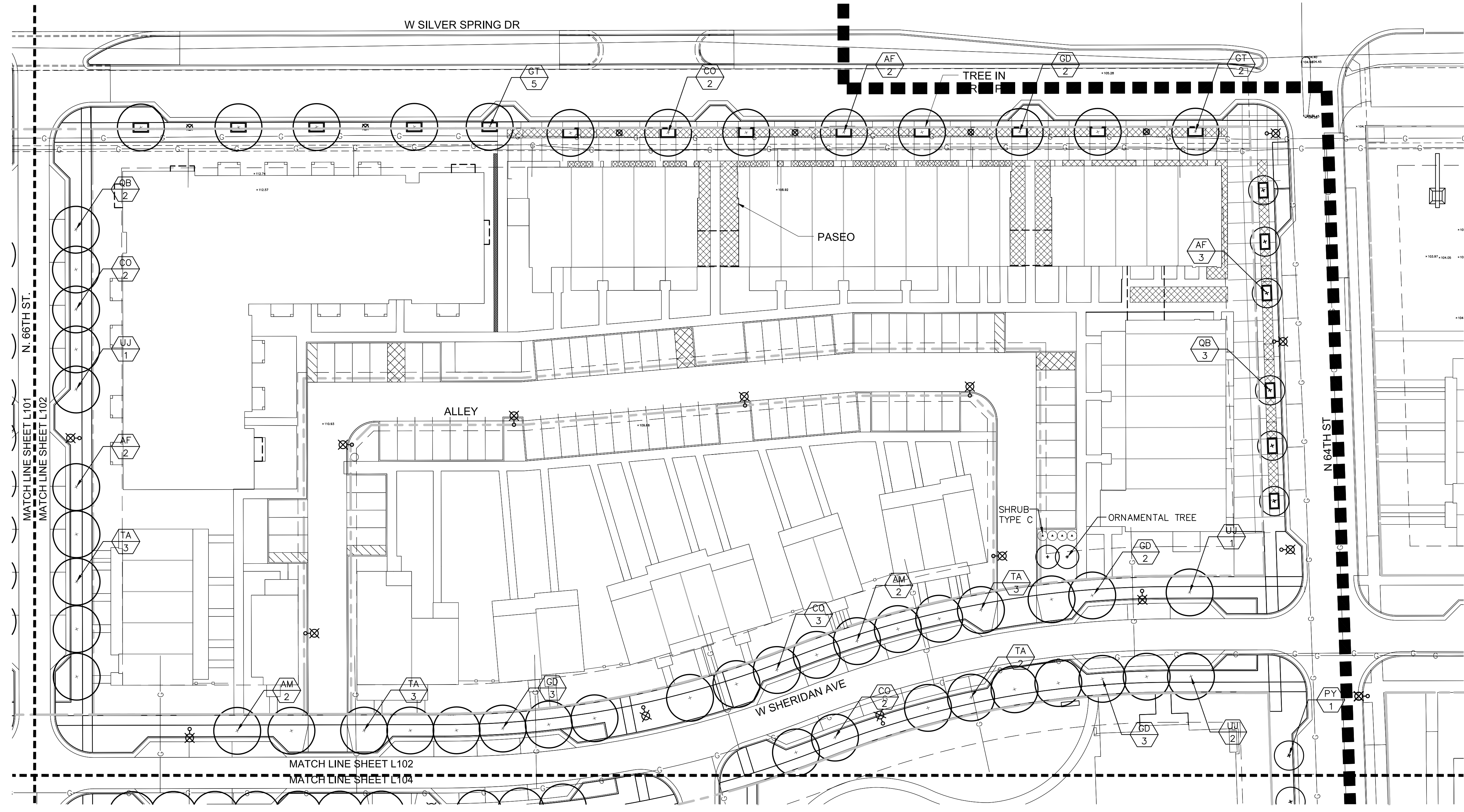

File: P:\P2-100\1052_WestlawnPhase2\CD\PLD\PLD_Landscape.dwg Layout: L102 User: mironowd Plotted: Nov 03, 2016 11:46am

WESTLAWN GARDENS PHASE II

6331 W Silver Spring Dr
MILWAUKEE WI 53218

Owner
 Housing Authority of the City of Milwaukee
414.286.3629

Architect
 Torti Gallas and Partners, Inc.
1300 Spring Street, 4th Floor
Silver Spring, MD 20910
301.588.4800
www.tortigallas.com

Local Architect
 Quorum Architects
414.265.9265

Local Architect
 Eppstein Uhen Architects
414.271.5350

Structural Engineer:
[R.A. Smith National](#)
262.317.3279

MEP Engineers:
 Thunderbird Engineering, Inc.
414.352.2211

IBC Engineering Services, Inc.
262.549.1190

Civil Engineer:
[R.A. Smith National](#)
262.522.4416

Landscape Architect:
 AVRES ASSOCIATES
608.255.0800

Issue
 No. _____ Date _____

Revisions
 No. _____ Date _____

Landscape Plan

Date _____
 Principal In Charge
 D.W.
 Project Planner
 Project Landscape Architect
 B.M.
 Project Manager
 B.M.
 Drawn
 B.M., R.S., S.K.
 Job No.
 27-1052
 Scale
 1" = 30'-0"

Drawing No.
L103

TORTI GALLAS AND PARTNERS, INC.

LEGEND

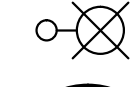
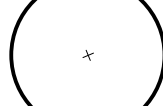
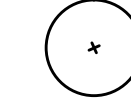
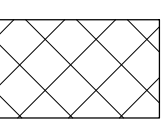
-  HARP LIGHT
-  ROADWAY LIGHT
-  CANOPY TREE
-  TREE UNDER POWER LINE
-  SPECIAL PAVEMENT

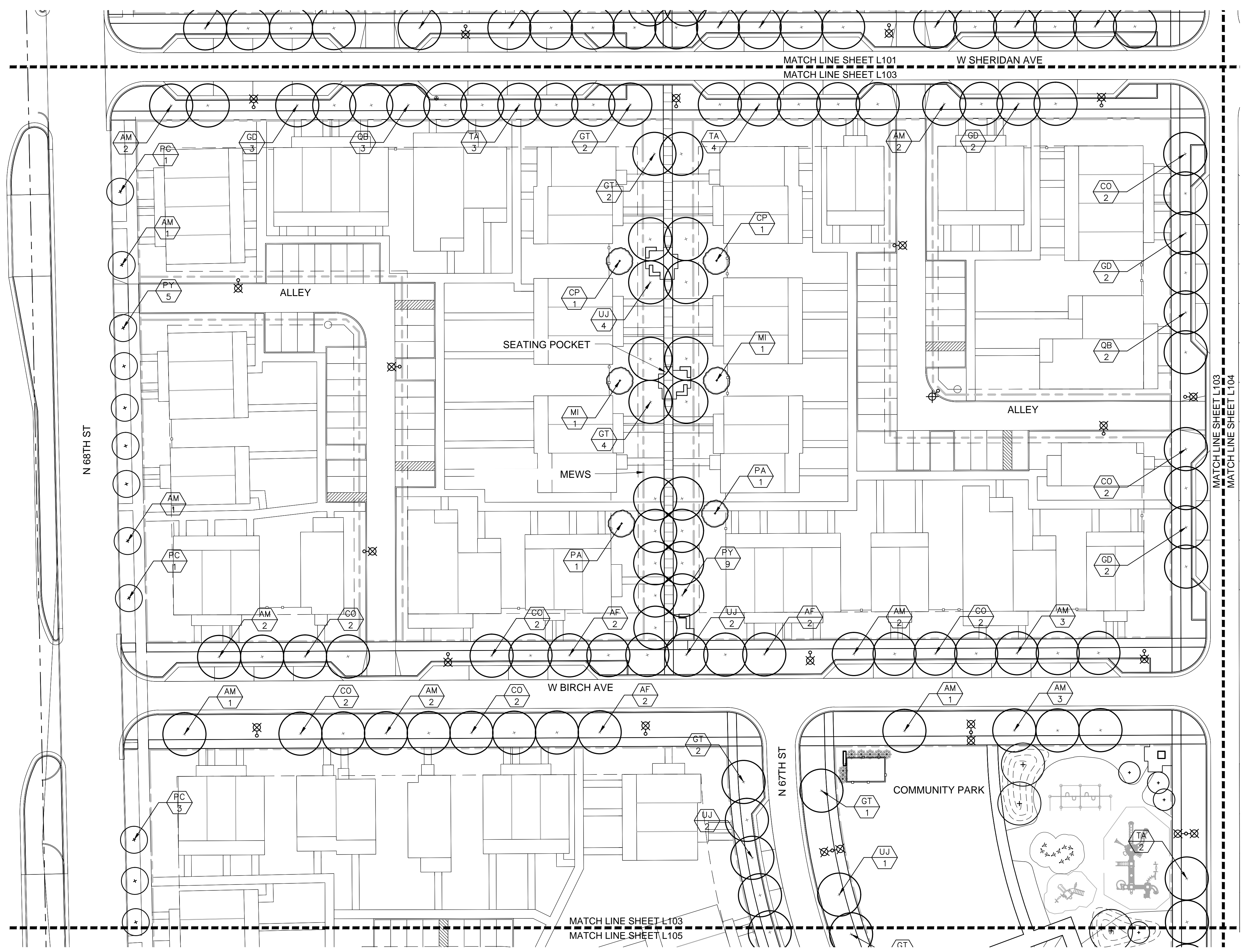

File: P:\27-1052\WestlawnPhase2\CD\VP\050_Landscape.dwg Layout: L103 User: stehr Plotter: Sep 30, 2016 - 11:50am

WESTLAWN GARDENS PHASE II

6331 W Silver Spring Dr
MILWAUKEE WI 53218

Owner
Housing Authority of the City of Milwaukee
414.286.3629

Architect
Torti Gallas and Partners, Inc.
1300 Spring Street, 4th Floor
Silver Spring, MD 20910
301.588.4800
www.tortigallas.com

Local Architect
Quorum Architects
414.265.9265

Local Architect
Eppstein Uhen Architects
414.271.5350

Structural Engineer:
R.A. Smith National
262.317.3279

MEP Engineers:
Thunderbird Engineering, Inc.
414.352.2211

IBC Engineering Services, Inc.
262.549.1190

Civil Engineer:
R.A. Smith National
262.522.4416

Landscape Architect:
AVRES ASSOCIATES
608.255.0800

Issue
No. _____ Date _____

Revisions
No. _____ Date _____

Landscape Plan

Date
Friday, October 14, 2016
Principal In Charge
D.W.
Project Planner

Project Landscape Architect
B.M.
Project Manager
B.M.
Drawn
B.M., R.S., S.K.

Job No.
13020.02
Scale
1" = 30'-0"

Drawing No.
L104

LEGEND

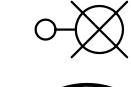
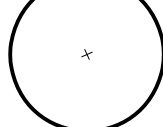
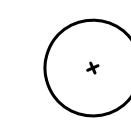
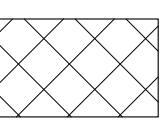
-  HARP LIGHT
-  ROADWAY LIGHT
-  CANOPY TREE
-  TREE UNDER POWER LINE
-  SPECIAL PAVEMENT

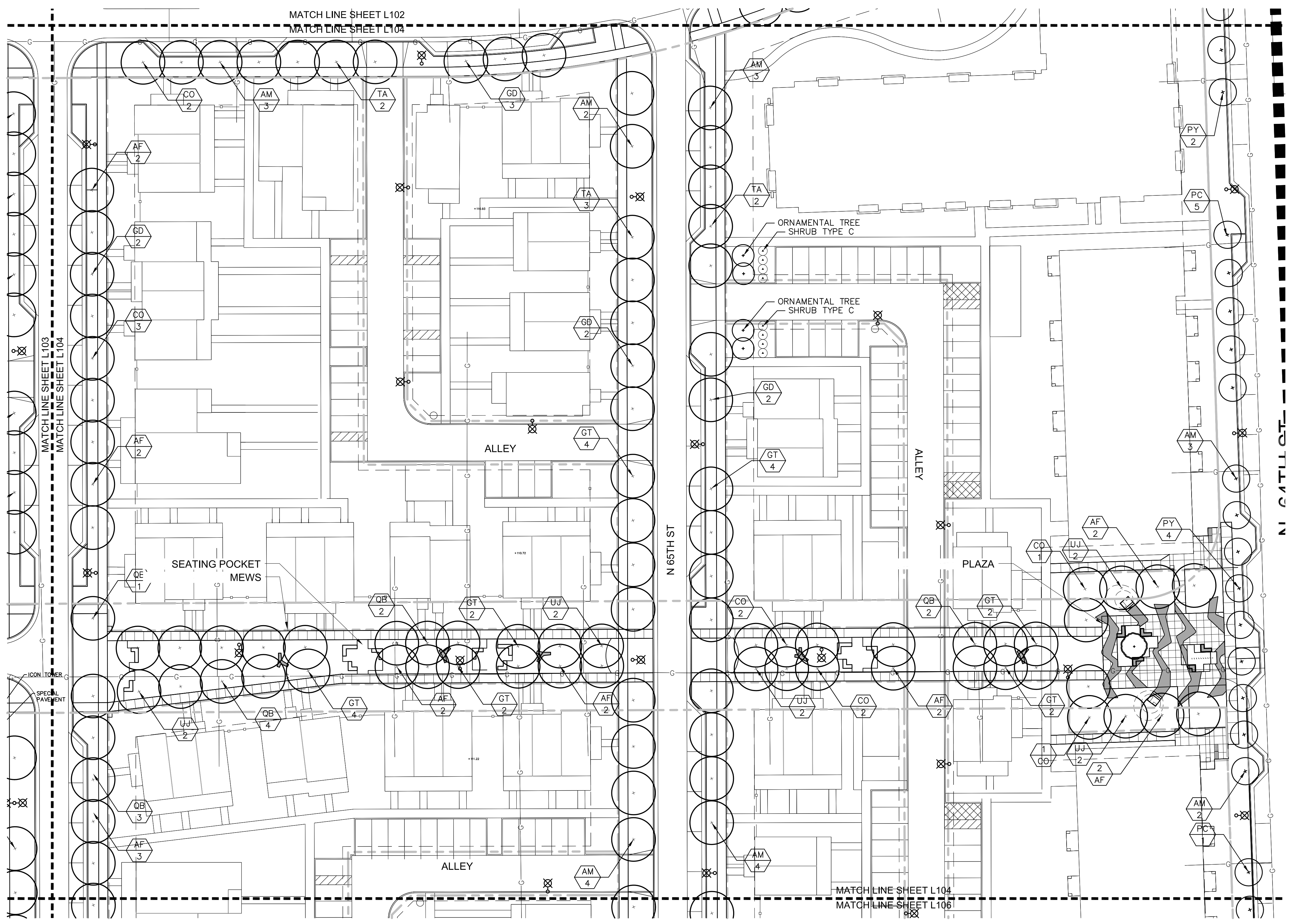

DESIGN DEVELOPMENT SET

TORTI GALLAS AND PARTNERS, INC. VICTORY MANOR AT THE WESTLAWN GARDENS

File: P:\P2-1000\1002_WestlawnPhase2\CD\PLANS_Landscape.dwg Layout: L104 User: mironowb Plotted: Nov 03, 2016 - 11:47am

WESTLAWN GARDENS PHASE II

6331 W Silver Spring Dr
MILWAUKEE WI 53218

Owner
Housing Authority of the City of Milwaukee
414.286.3629

Architect
Torti Gallas and Partners, Inc.
1300 Spring Street, 4th Floor
Silver Spring, MD 20910
301.588.4800
www.tortigallas.com

Local Architect
Quorum Architects
414.265.9265

Local Architect
Eppstein Uhen Architects
414.271.5350

Structural Engineer:
R.A. Smith National
262.317.3279

MEP Engineers:
Thunderbird Engineering, Inc.
414.352.2211

IBC Engineering Services, Inc.
262.549.1190

Civil Engineer:
R.A. Smith National
262.522.4416

Landscape Architect:
AVRES ASSOCIATES
608.255.0800

Issue
No. _____ Date _____

Revisions
No. _____ Date _____

Landscape Plan

Date _____
Principal In Charge
D.W.
Project Planner
Project Landscape Architect
B.M.
Project Manager
B.M.
Drawn
B.M., R.S., S.K.
Job No.
27-1052
Scale
1" = 30'-0"

Drawing No.
L105

LEGEND

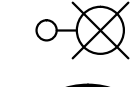
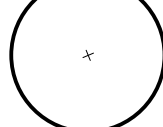
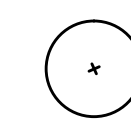
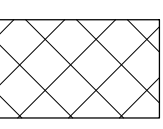
-  HARP LIGHT
-  ROADWAY LIGHT
-  CANOPY TREE
-  TREE UNDER POWER LINE
-  SPECIAL PAVEMENT

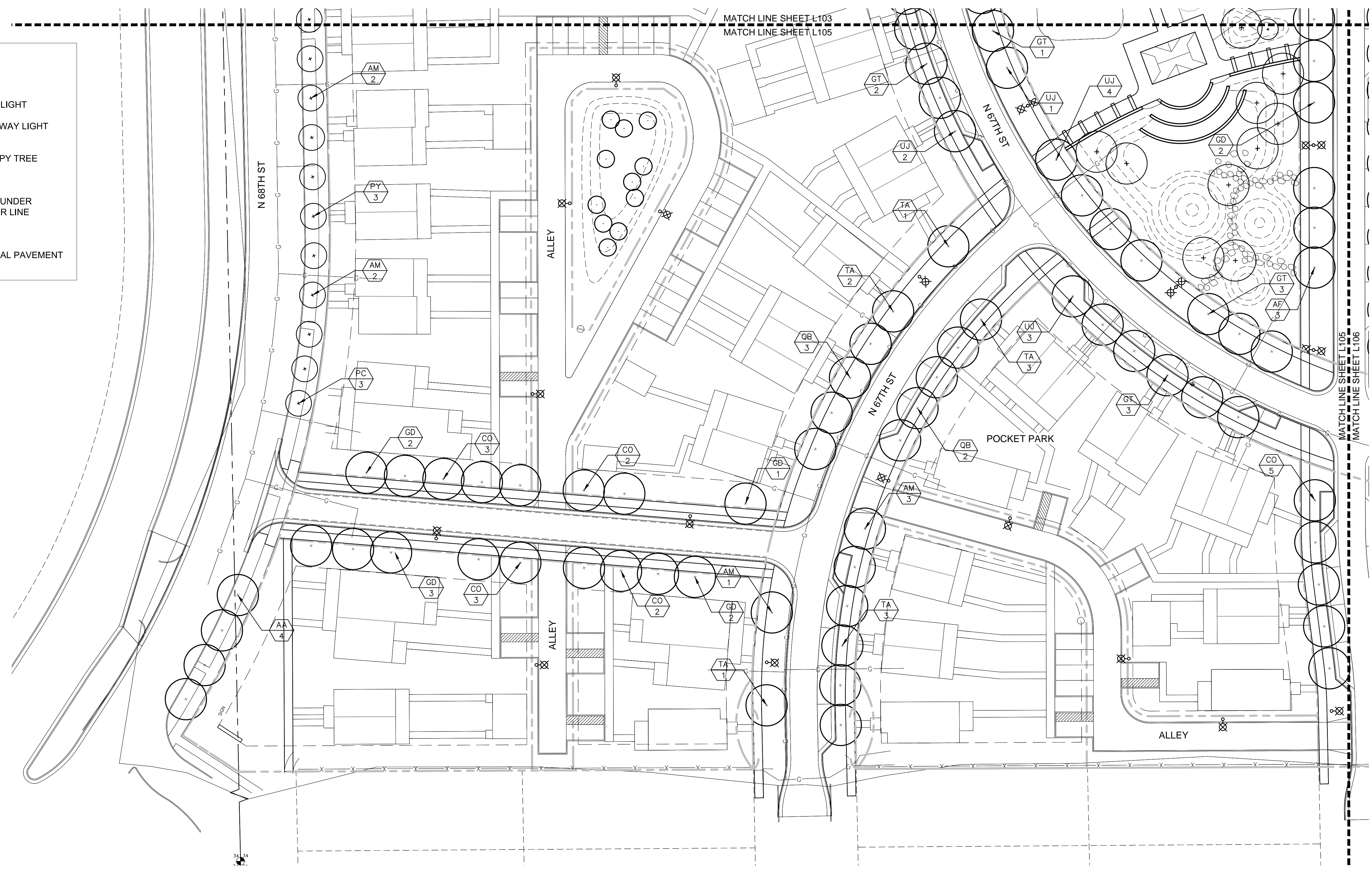

File: P:\27-1052\WestlawnPhase2\CD\VP_DPS_Landscape.dwg Layout: L105 User: stehr Plotted: Sep 30, 2016 - 11:51am

WESTLAWN GARDENS PHASE II

6331 W Silver Spring Dr
MILWAUKEE WI 53218

Owner
Housing Authority of the City of Milwaukee
414.286.3629

Architect
Torti Gallas and Partners, Inc.
1300 Spring Street, 4th Floor
Silver Spring, MD 20910
301.588.4800
www.tortigallas.com

Local Architect
Quorum Architects
414.265.9265

Local Architect
Eppstein Uhen Architects
414.271.5350

Structural Engineer:
R.A. Smith National
262.317.3279

MEP Engineers:
Thunderbird Engineering, Inc.
414.352.2211

IBC Engineering Services, Inc.
262.549.1190

Civil Engineer:
R.A. Smith National
262.522.4416

Landscape Architect:
AVRES ASSOCIATES
608.255.0800

Issue
No. Date

Revisions
No. Date

Landscape Plan

Date
Friday, October 14, 2016
Principal In Charge
D.W.
Project Planner

Project Landscape Architect
B.M.
Project Manager
B.M.
Drawn
B.M., R.S., S.K.
Job No.
13020.02
Scale
1" = 30'-0"

Drawing No.
L106

TORTI GALLAS AND PARTNERS, INC. VICTORY MANOR AT THE WESTLAWN GARDENS

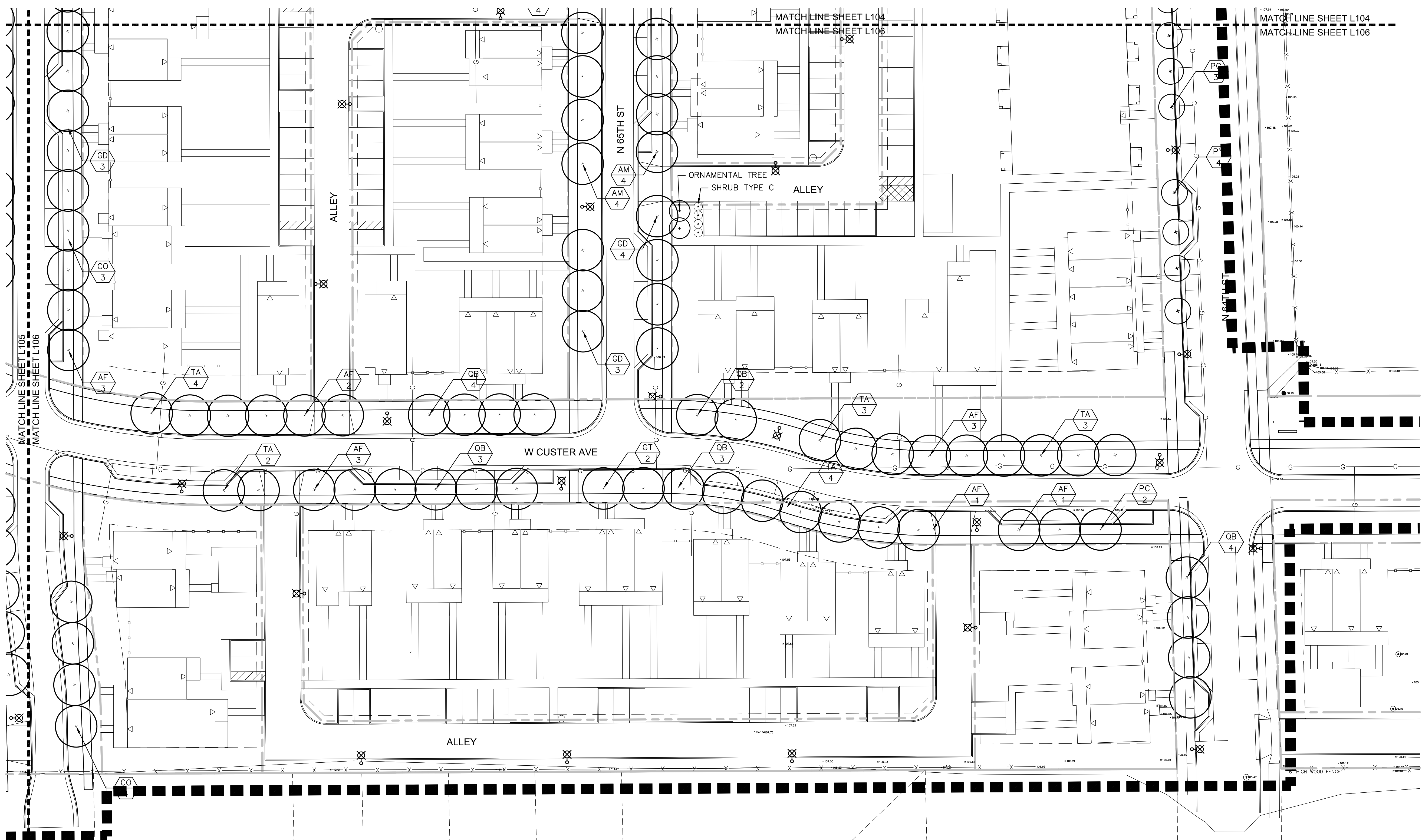

LEGEND

- HARP LIGHT
- ROADWAY LIGHT
- CANOPY TREE
- TREE UNDER POWER LINE
- SPECIAL PAVEMENT

File: P:\P2-1000\1052_WestlawnPhase2\CD\PLD\PLD_Landscape.dwg Layout: L106 User: mironowd Plotted: Nov 03, 2016 11:45am

LANDSCAPE PLANT LEGEND

Symbol	Botanical name	Common Name	Size	Root	Quantity	Comments
SHADE TREES						
AF	Acer x freemanii 'Morgan'	Morgan Freeman Maple	2.5" Cal.	B&B	42	Low Allergy
AM	Acer miyabei 'Morton'	State Street Maple	2.5" Cal.	B&B	56	
BN	Betula nigra 'Heritage'	Heritage River Birch	2.5" Cal.	B&B	x	Multi-stem
CO	Celtis occidentalis 'Prairie Pride'	Prairie Pride Hackberry	2.5" Cal.	B&B	62	
GD	Gymnocladus dioicus	Kentucky Coffee Tree	2.5" Cal.	B&B	59	
GT	Gleditsia triacanthos 'Skycote'	Skyline Honeylocust	2.5" Cal.	B&B	40	Low Allergy
PC	Pyrus 'Cleveland Select'	Cleveland Select Pear	2.5" Cal.	B&B	17	Low Allergy
PY	Pyrus 'Aristocrat'	Aristocrat Pear	2.5" Cal.	B&B	23	Low Allergy
QB	Quercus bicolor	Swamp White Oak	2.5" Cal.	B&B	46	
TA	Tilia Americana	American Linden	2.5" Cal.	B&B	65	
UJ	Ulmus japonica x vilsoniana 'Morton'	Accolade Elm	2.5" Cal.	B&B	33	

ORNAMENTAL TREES						
AG	Amelanchier x grandiflora	Apple Serviceberry	2.5" Cal.	B&B	2	Low Allergy
CC	Carpinus caroliniana	American Hornbeam	2.5" Cal.	B&B	x	
CP	Crataegus 'Princeton Sentry'	Princeton Sentry Hawthorn	2.5" Cal.	B&B	2	Low Allergy
CG	Crataegus crus-galli var. inermis	Thornless Cockspur Hawthorn	2.5" Cal.	B&B	x	Low Allergy
MI	Malus 'Adirondack'	Adirondack Crabapple	2.5" Cal.	B&B	2	Low Allergy
PA	Prunus maackii	Amur Chokecherry	2.5" Cal.	B&B	2	Low Allergy

EVERGREEN TREES						
JV	Juniperus virginiana 'Burkii'	Burkii Eastern Redcedar	8' Ht.	B&B	x	
PD	Picea glauca var. densata	Black Hills Spruce	8' Ht.	B&B	x	Low Allergy

SHRUB TYPE A (> 8' ht.)						
Ap	Aesculus parviflora	Bottlebrush Buckeye	3'-5' Ht.	B&B	x	
Fm	Forsythia x 'Meadowlark'	Meadowlark Forsythia	3'-5' Ht.	B&B	x	
Hv	Hamamelis virginiana	Common Witchhazel	3'-5' Ht.	B&B	x	
Po	Physocarpus opulifolius	Common Ninebark	3'-5' Ht.	B&B	x	Low Allergy
Sv	Spiraea x vanhouttei	Bridal Wreath Spirea	3'-5' Ht.	B&B	x	

SHRUB TYPE B (4'-8' ht.)						
Aa	Aronia arbutifolia	Red Chokeberry	5 Gal.	CG	x	Low Allergy
Ca	Clethra alnifolia 'Hummingbird'	Hummingbird Clethra	5 Gal.	CG	x	Low Allergy
Cl	Cotoneaster lucidus	Hedge Cotoneaster	5 Gal.	CG	x	Low Allergy
Cs	Cornus sericea 'Isanti'	Isanti Redtwig Dogwood	5 Gal.	CG	x	Low Allergy
Hp	Hydrangea paniculata 'Limelight'	Panicle Hydrangea	5 Gal.	CG	x	Low Allergy
Iv	Ilex verticillata	Winterberry	5 Gal.	CG	x	
Rr	Rosa 'Radsunny'	The Sunny Knock Out Rose	5 Gal.	CG	x	Low Allergy
Sp	Syringa patula 'Miss Kim'	Miss Kim Lilac	5 Gal.	CG	x	
Vd	Viburnum dentatum 'Blue Muffin'	Blue Muffin Viburnum	5 Gal.	CG	x	Low Allergy

SHRUB TYPE C (< 4' ht.)						
Bg	Buxux 'Green Velvet'	Green Velvet Boxwood	3 Gal.	CG	x	
De	Deutzia gracilis	Slender Deutzia	3 Gal.	CG	x	
Di	Diervilla lonicera	Dwarf Bush Honeysuckle	3 Gal.	CG	x	
Fg	Fothergilla gardenii 'Mt. Airy'	Mt. Airy Dwarf Fothergilla	3 Gal.	CG	x	
Ha	Hydrangea arborescens 'Annabelle'	Annabelle Hydrangea	3 Gal.	CG	x	
Pf	Potentilla fruticosa 'Abbotswood'	White Potentilla	3 Gal.	CG	x	
Ra	Rhus aromatica 'Gro-Low'	Gro-Low Fragrant Sumac	3 Gal.	CG	x	
Sa	Spiraea x bumalda 'Anthony Waterer'	Anthony Waterer Spirea	3 Gal.	CG	x	
Sj	Spiraea x bumalda 'Crispa'	Crispa Spirea	3 Gal.	CG	x	
Sn	Spiraea nipponica	Snowmound Spirea	3 Gal.	CG	x	
Vo	Viburnum opulus 'Nanum'	European Cranberrybush	3 Gal.	CG	x	

SHRUB TYPE D (Evergreen; 5'-8' Ht.)						
Tr	Thuja occidentalis 'Robusta'	Ware or Robusta Juniper	3 Gal.	CG	x	

SHRUB TYPE D (Evergreen; 2'-5' Ht.)						
Jb	Juniperus squamata 'Blue Star'	Blue Star Juniper	3 Gal.	CG	x	
Jh	Juniperus horizontalis 'Bar Harbor'	Bar Harbor Creeping Juniper	3 Gal.	CG	x	
Jm	Juniperus squamata 'Meyeri'	Blue Star Juniper	3 Gal.	CG	x	
Jp	Juniperus 'Pfitzeriana Compacta'	Compact Pfitzer Juniper	3 Gal.	CG	x	
Js	Juniperus chinensis 'Sea Green'	Sea Green Juniper	3 Gal.	CG	x	
Tm	Taxus x media 'Tauntonii'	Taunton Yew	3 Gal.	CG	x	

PERENNIALS/GRASSES/GROUNDCOVERS						
ac	Aquilegia canadensis	American Columbine	1 Gal.	CG	x	
ad	Aster divaricatus	White Wood Aster	1 Gal.	CG	x	
am	Alchemilla ssp.	Lady's Mantle	1 Gal.	CG	x	
ar	Ajuga reptans	Bugleweed	1 Gal.	CG	x	
ca	Calamagrostis acutiflora 'Karl Foerster'	Karl Foerster Feather Reed Grass	1 Gal.	CG	x	
cl	Chasmanthium latifolia	Northern Sea Oats	1 Gal.	CG	x	
cp	Carex pennsylvanica	Pennsylvania Sedge	1 Gal.	CG	x	
ef	Euonymus fortuneii coloratus	Wintercreeper	1 Gal.	CG	x	
ep	Echinacea purpurea	Purple Coneflower	1 Gal.	CG	x	
gm	Geranium maculatum	Wild Geranium	1 Gal.	CG	x	
ho	Hosta 'Blue Angel'	Blue Angel Hosta	1 Gal.	CG	x	
hh	Hemerocallis 'Happy Returns'	Happy Returns Daylily	1 Gal.	CG	x	
hm	Hemerocallis 'Mini Stella'	Mini Stella Daylily	1 Gal.	CG	x	
hs	Helictotrichon sempervirens	Blue Oat Grass	1 Gal.	CG	x	
mf	Monarda 'Petite Delight'	Petite Delight Beebalm	1 Gal.	CG	x	
pl	Phlox subulata	Creeping Phlox	1 Gal.	CG	x	
ps	Panicum virgatum 'Shenandoah'	Shenandoah Switch Grass	1 Gal.	CG	x	
pt	Pachysandra terminalis	Japanese spurge	1 Gal.	CG	x	
pq	Parthenocissus quinquefolia 'Star Showers'	Star Showers Virginia Creeper	1 Gal.	CG	x	
sh	Sporobolus heterolepis	Prairie Dropseed	1 Gal.	CG	x	
wt	Waldstenia ternata	Barren Strawberry	1 Gal.	CG	x	

WESTLAWN GARDENS PHASE II

6331 W Silver Spring Dr
MILWAUKEE WI 53218

Owner

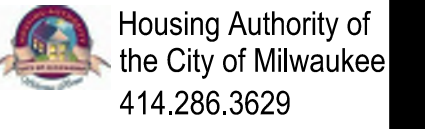

Housing Authority of the City of Milwaukee
414.286.3629

Local Architect



Quorum Architects
414.265.9265

Local Architect



Eppstein Uhen Architects
414.271.5350

Structural Engineer:

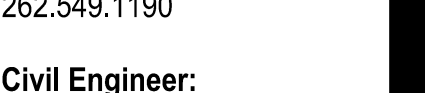

R.A. Smith National
262.317.3279

MEP Engineers:



Thunderbird Engineering, Inc.
414.352.2211

IBC Engineering Services, Inc.



262.549.1190

Civil Engineer:



R.A. Smith National
262.522.4416

Landscape Architect:



AVRES ASSOCIATES
608.255.0800

Issue

No. _____ Date _____

Revisions

No. _____ Date _____

Landscape Plan

Date _____

Principal In Charge
D.W.

Project Planner

Project Landscape Architect
B.M.

Project Manager
B.M.

Drawn
B.M., R.S., S.K.

Job No.
27-1052

Scale
No Scale

Drawing No.

L107

WESTLAWN GARDENS PHASE II

6331 W Silver Spring Dr
MILWAUKEE WI 53218

Owner
Housing Authority of the City of Milwaukee
414.286.3629

Architect
Torti Gallas and Partners, Inc.
1300 Spring Street, 4th Floor
Silver Spring, MD 20910
301.588.4800
www.tortigallas.com

Local Architect
Quorum Architects
414.265.9265

Local Architect
Eppstein Uhen Architects
414.271.5350

Structural Engineer:
R.A. Smith National
262.317.3279

MEP Engineers:
Thunderbird Engineering, Inc.
414.352.2211

IBC Engineering Services, Inc.
262.549.1190

Civil Engineer:
R.A. Smith National
262.522.4416

Landscape Architect:
AVRES ASSOCIATES
608.255.0800

Issue No. _____ Date _____

Revisions No. _____ Date _____

Typical Lots

Date _____
Principal In Charge D.W.
Project Planner _____
Project Landscape Architect B.M.
Project Manager B.M.
Drawn B.M., R.S., S.K.
Job No. 27-1052
Scale 1" = 10'-0"
Drawing No. _____

L200

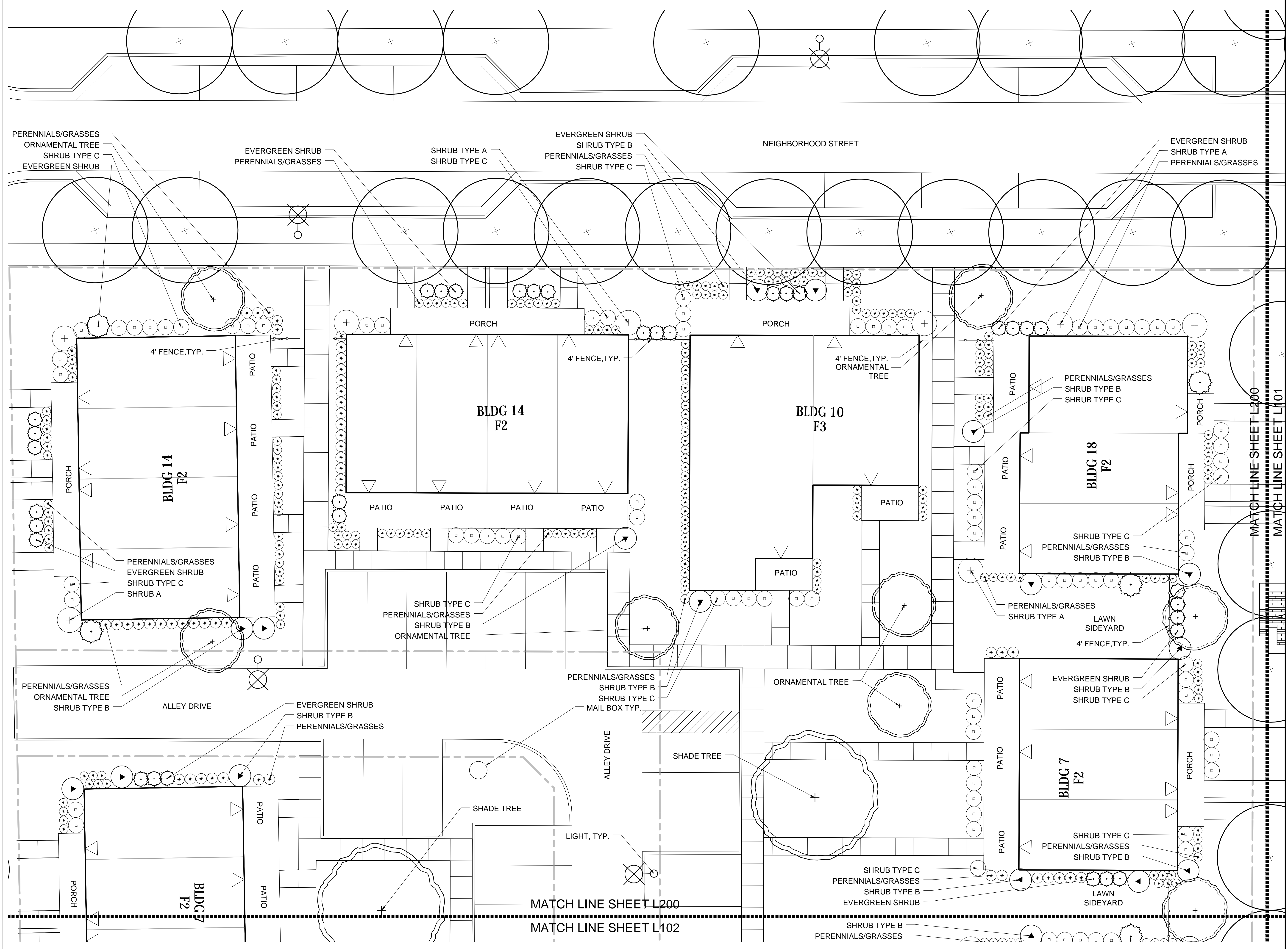

File: P:\27-1052\WestlawnPhase2\CAD\VP_L200_TypicalLots.dwg Layout: L200 User: slabin Plotter: Sep 30, 2016 11:41 am

TORTI GALLAS AND PARTNERS, INC. WESTLAWN gardens, phase II

File: P:\12-1001\1052_MeridianPhase2\CD\VP_L201_Tortigallas_Dwgs\Site\Site.dwg Layout: L201 User: stalin Plotter: Sep 30, 2016 - 11:41 am

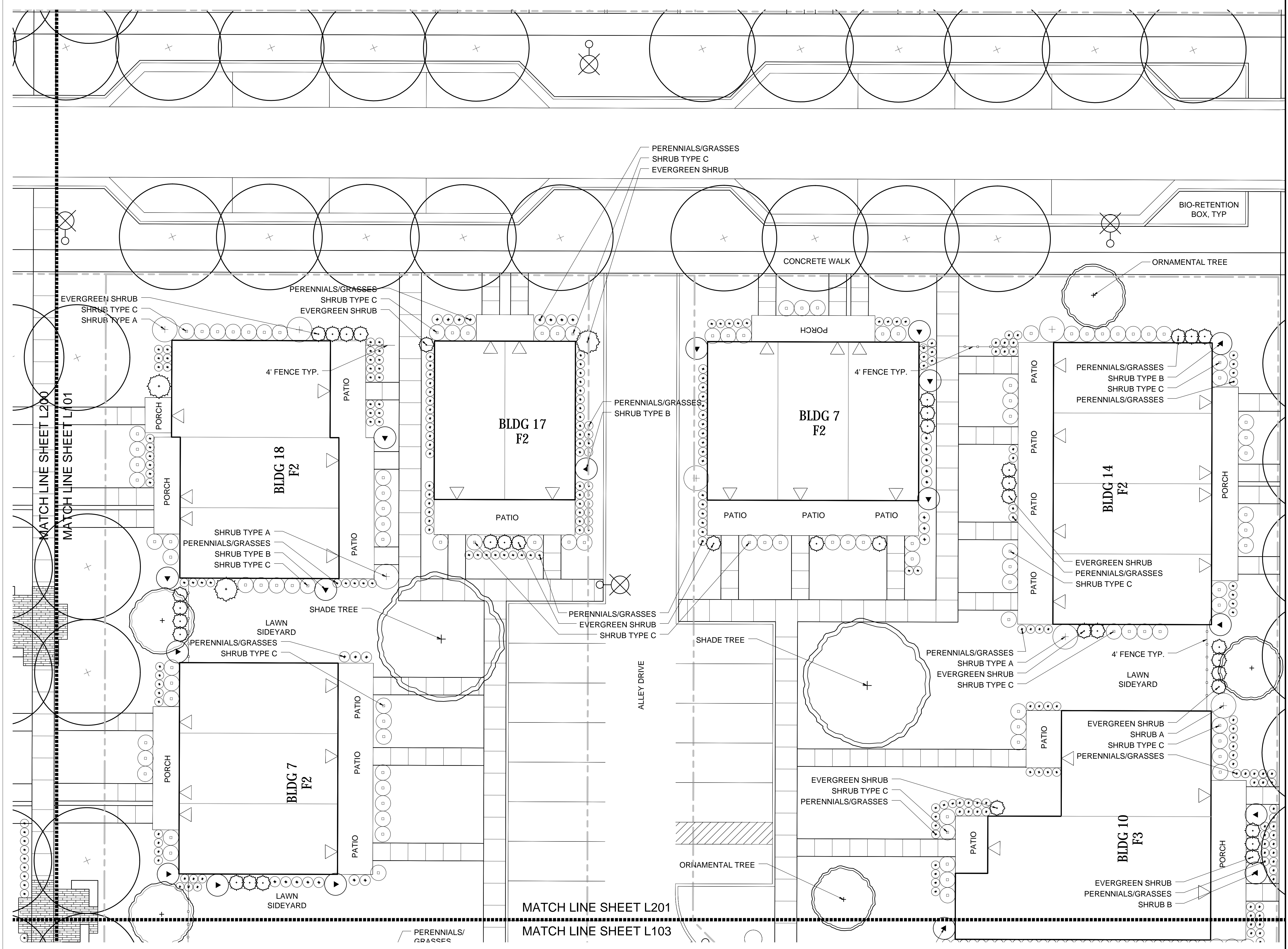

WESTLAWN GARDENS PHASE II
6331 W Silver Spring Dr
MILWAUKEE WI 53218
Owner
Housing Authority of the City of Milwaukee
414.286.3629
Architect
Torti Gallas and Partners, Inc.
1300 Spring Street, 4th Floor
Silver Spring, MD 20910
301.588.4800
www.tortigallas.com

Local Architect
Quorum Architects
414.265.9265

Local Architect
Eppstein Uhen Architects
414.271.5350

Structural Engineer:
R.A. Smith National
262.317.3279

MEP Engineers:
Thunderbird Engineering, Inc.
414.352.2211

IBC Engineering Services, Inc.
262.549.1190

Civil Engineer:
R.A. Smith National
262.522.4416

Landscape Architect:
AVRES ASSOCIATES
608.255.0800

Issue
No. _____ Date _____

Revisions
No. _____ Date _____

Typical Lots

Date _____
Principal In Charge
D.W.
Project Planner
Project Landscape Architect
B.M.
Project Manager
B.M.
Drawn
B.M., R.S., S.K.
Job No.
27-1052
Scale
1" = 10'-0"
Drawing No.

L201

TORTI GALLAS AND PARTNERS, INC.
WESTLAWN gardens, phase II

MATCH LINE SHEET L200
MATCH LINE SHEET L102

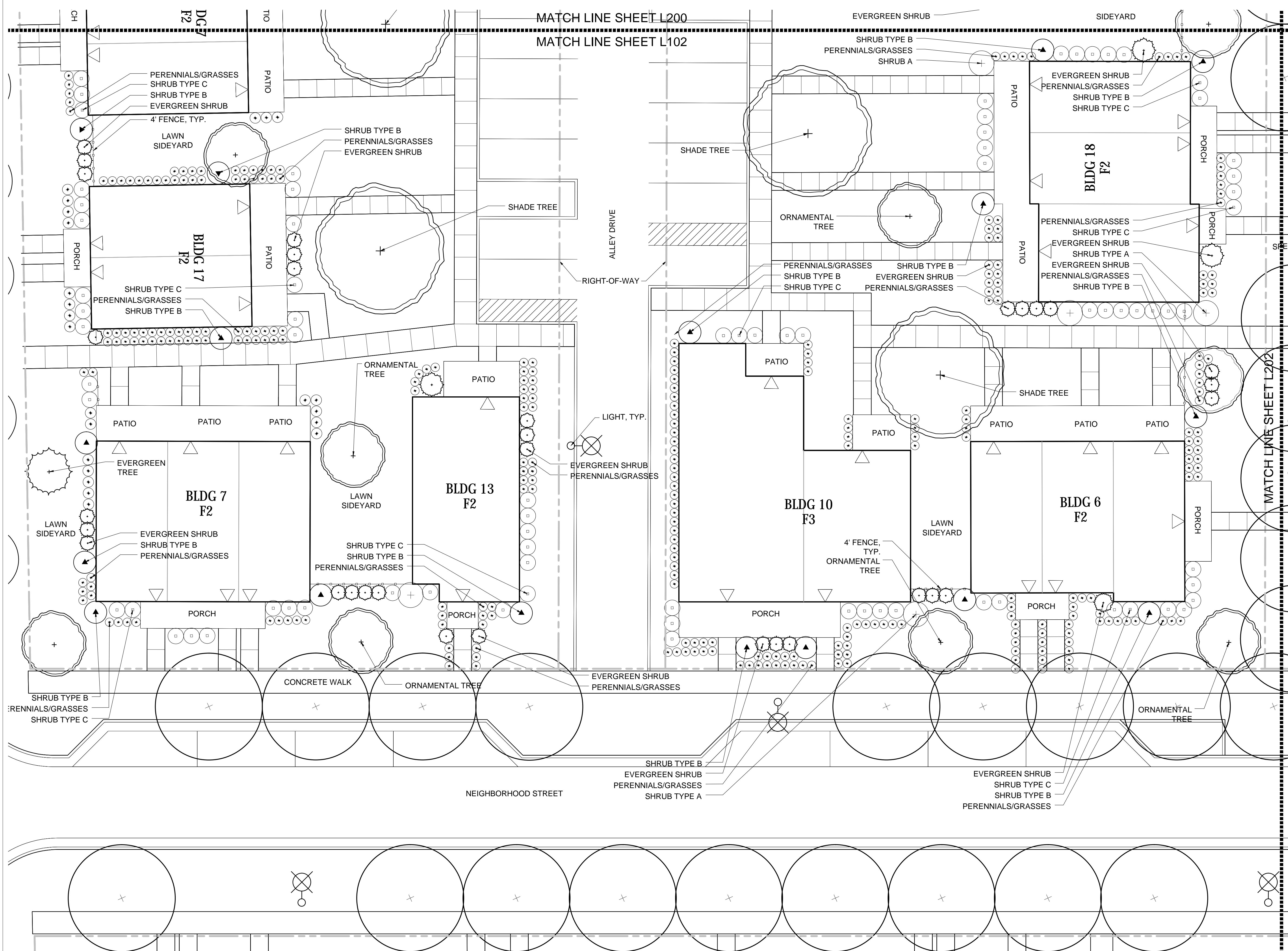

WESTLAWN GARDENS PHASE II
6331 W Silver Spring Dr
MILWAUKEE WI 53218

Owner
Housing Authority of the City of Milwaukee
414.286.3629

Architect
Torti Gallas and Partners, Inc.
1300 Spring Street, 4th Floor
Silver Spring, MD 20910
301.588.4800
www.tortigallas.com

Local Architect
Quorum Architects
414.265.9265

Local Architect
Eppstein Uhen Architects
414.271.5350

Structural Engineer:
R.A. Smith National
262.317.3279

MEP Engineers:
Thunderbird Engineering, Inc.
414.352.2211

IBC Engineering Services, Inc.
262.549.1190

Civil Engineer:
R.A. Smith National
262.522.4416

Landscape Architect:
AVRES ASSOCIATES
608.255.0800

Issue
No. _____ Date _____

Revisions
No. _____ Date _____

Typical Lots

Date _____
Principal In Charge
D.W.
Project Planner
Project Landscape Architect
B.M.
Project Manager
B.M.
Drawn
B.M., R.S., S.K.
Job No.
27-1052
Scale
1" = 10'-0"

Drawing No.
L202

File: P:\27-1052\WestlawnPhase2\CD\CD_V_PDF\CD_V_PDF\CD_V_PDF\CD_V_PDF.dwg
 Layout: L202
 User: stein
 Plotter: Sep 30, 2016 - 11:41 am

TORTI GALLAS AND PARTNERS, INC.

**WESTLAWN
GARDENS
PHASE II**

6331 W Silver Spring Dr
MILWAUKEE WI 53218

Owner
Housing Authority of
the City of Milwaukee
414.286.3629

Architect
Torti Gallas
and Partners, Inc.
1300 Spring Street, 4th Floor
Silver Spring, MD 20910
301.588.4800
www.tortigallas.com

Local Architect
Quorum Architects
414.265.9265

Local Architect
Eppstein Uhen
Architects
414.271.5350

Structural Engineer:
R.A. Smith National
262.317.3279

MEP Engineers:
Thunderbird Engineering, Inc.
414.352.2211

IBC Engineering Services, Inc.
262.549.1190

Civil Engineer:
R.A. Smith National
262.522.4416

Landscape Architect:
AVRES
ASSOCIATES
608.255.0800

Issue
No. _____ Date _____

Revisions
No. _____ Date _____

Typical Lots

Date _____
Principal In Charge
D.W.
Project Planner

Project Landscape Architect
B.M.
Project Manager
B.M.
Drawn
B.M., R.S., S.K.
Job No.
27-1052
Scale
1" = 10'-0"

Drawing No.
L203

TORTI GALLAS AND PARTNERS, INC.

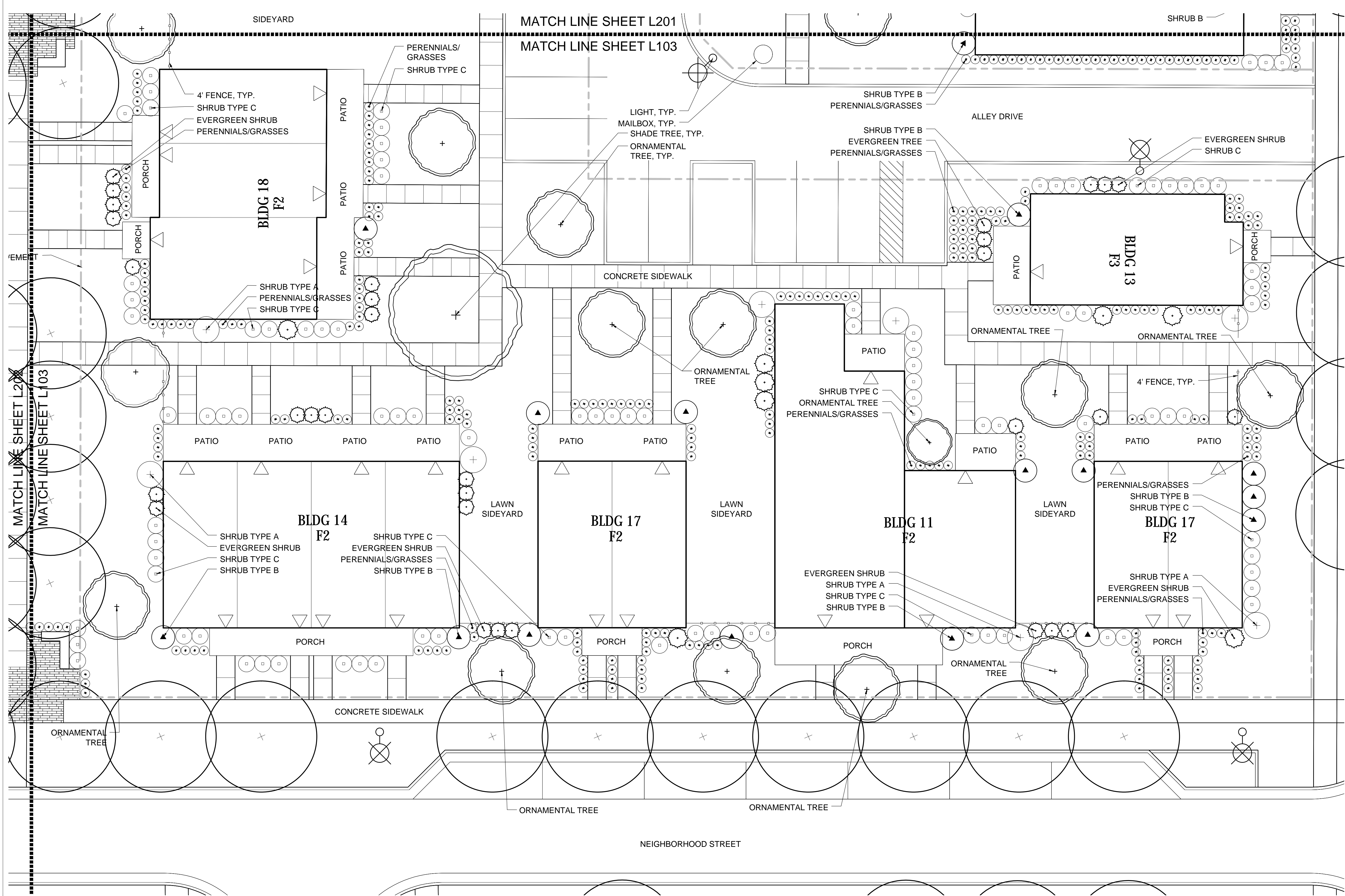

File: P:\27-1052 WestlawnPhase2\CAD\VP_050_Typhical_Lots.dwg Layout: L203 User: stehr Plotter: Sep 30, 2016 11:41 am

WESTLAWN GARDENS PHASE II

6331 W Silver Spring Dr
MILWAUKEE WI 53218

Owner
Housing Authority of the City of Milwaukee
414.286.3629

Architect
Torti Gallas and Partners, Inc.
1300 Spring Street, 4th Floor
Silver Spring, MD 20910
301.588.4800
www.tortigallas.com

Local Architect
Quorum Architects
414.265.9265

Local Architect
Eppstein Uhen Architects
414.271.5350

Structural Engineer:
R.A. Smith National
262.317.3279

MEP Engineers:
Thunderbird Engineering, Inc.
414.352.2211

IBC Engineering Services, Inc.
262.549.1190

Civil Engineer:
R.A. Smith National
262.522.4416

Landscape Architect:
AVRES ASSOCIATES
608.255.0800

Issue No. Date

Revisions No. Date

Typical Mixed Use

Date
Principal In Charge
D.W.
Project Planner
Project Landscape Architect
B.M.
Project Manager
B.M.
Drawn
B.M., R.S., S.K.
Job No.
27-1052
Scale
1" = 10'-0"

Drawing No.
L300

TORTI GALLAS AND PARTNERS, INC. WESTLAWN gardens, phase II

BLDG 2.1

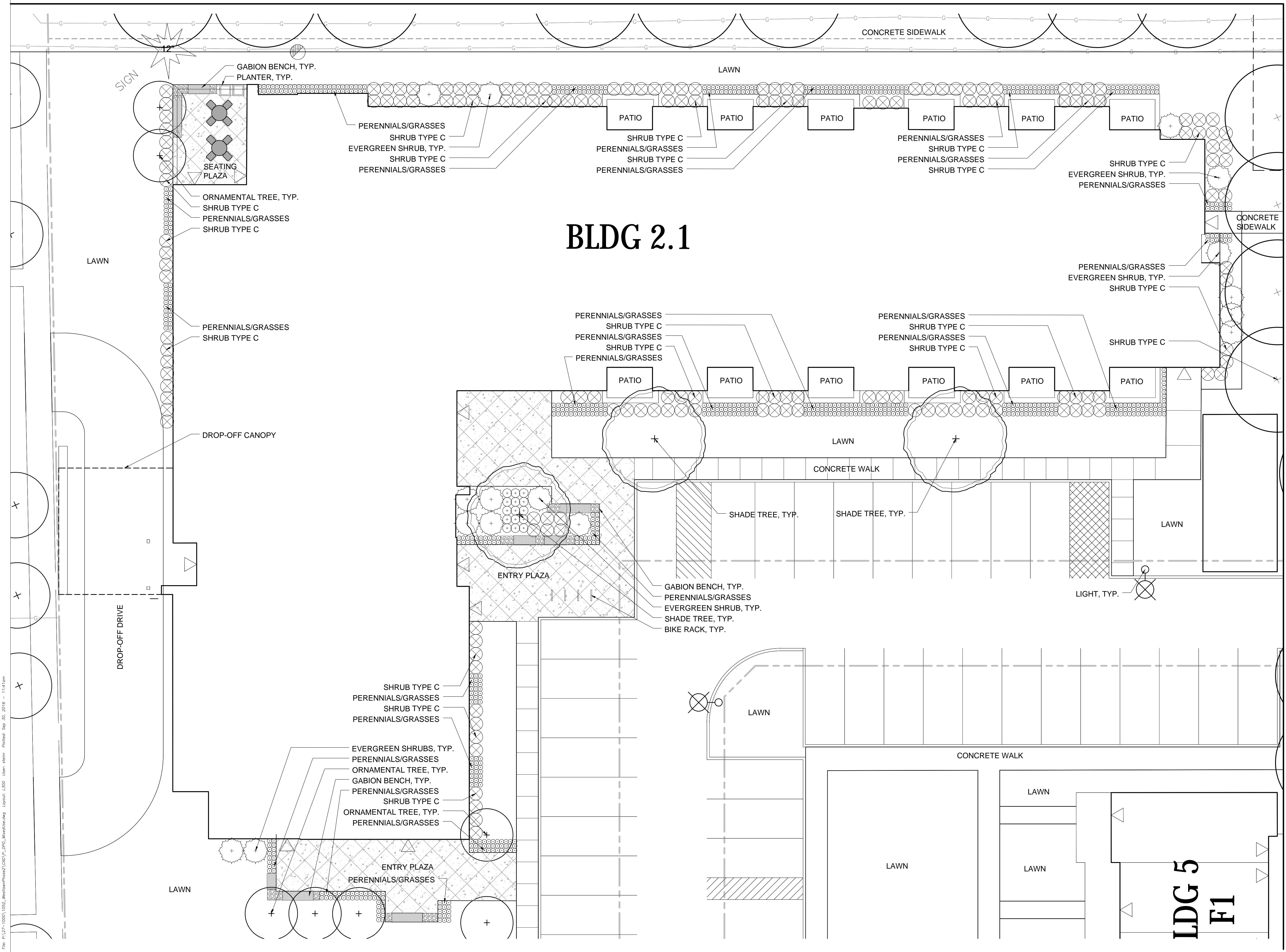

File: P:\27-1052\WestlawnPhase2\LDG5_F1.dwg Layout: L300 User: stier Plotter: Sep 30, 2016 - 11:41am

File: P:\27-1052_MeridianPhase2\LD\VP_050_Meridian.dwg Layout: L301 User: stelar Plotter: Sep 30, 2016 1:14:00

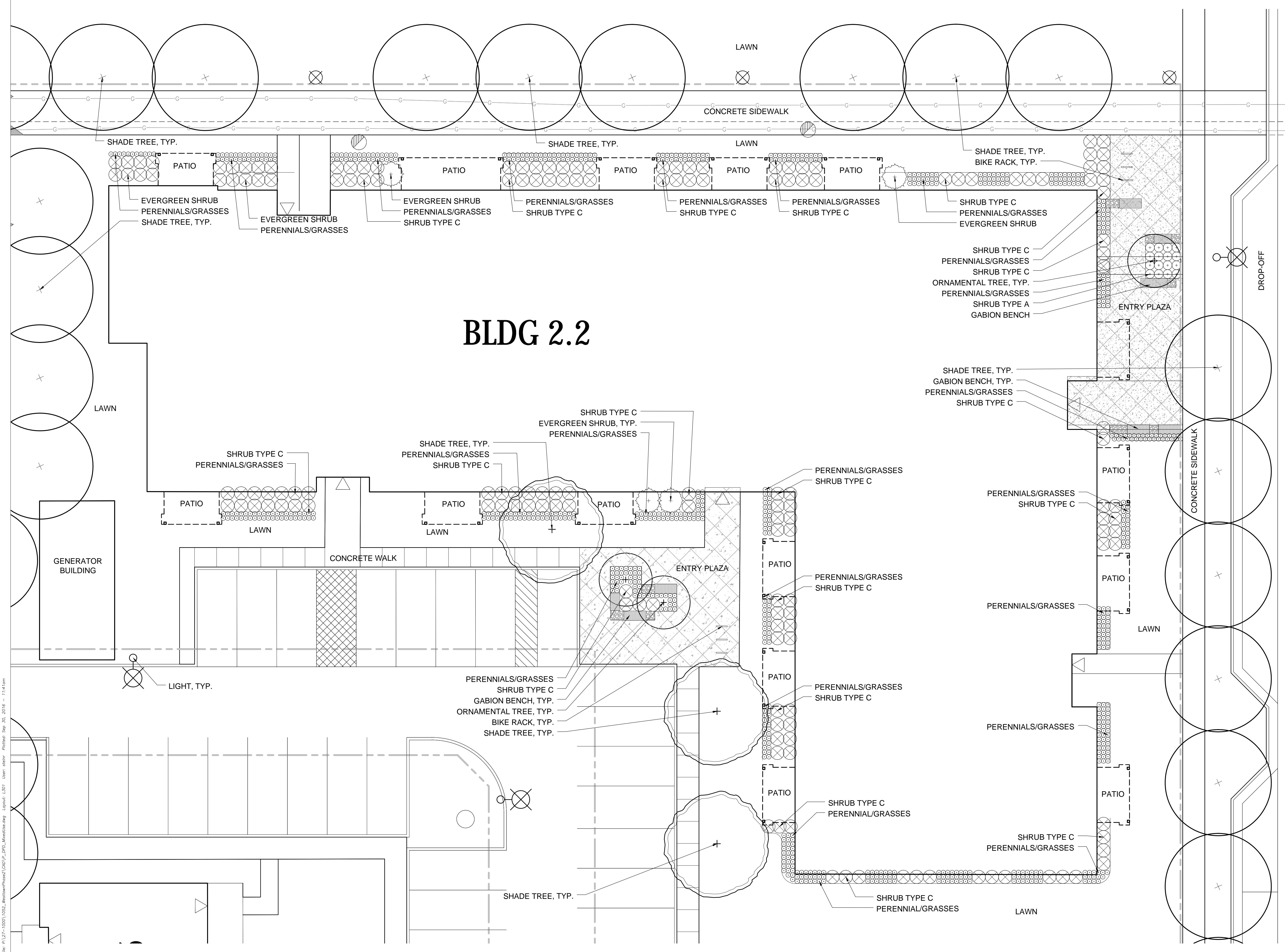

BLDG 2.2

WESTLAWN GARDENS PHASE II
 6331 W Silver Spring Dr
 MILWAUKEE WI 53218

Owner
 Housing Authority of the City of Milwaukee
 414.286.3629

Architect
 Torti Gallas and Partners, Inc.
 1300 Spring Street, 4th Floor
 Silver Spring, MD 20910
 301.588.4800
 www.tortigallas.com

Local Architect
 Quorum Architects
 414.265.9265

Local Architect
 Eppstein Uhen Architects
 414.271.5350

Structural Engineer:
 R.A. Smith National
 262.317.3279

MEP Engineers:
 Thunderbird Engineering, Inc.
 414.352.2211

IBC Engineering Services, Inc.
 262.549.1190

Civil Engineer:
 R.A. Smith National
 262.522.4416

Landscape Architect:
 AVRES ASSOCIATES
 608.255.0800

Issue

No.	Date

Revisions

No.	Date

Typical Mixed Use

Date
 Principal In Charge
 D.W.
 Project Planner
 Project Landscape Architect
 B.M.
 Project Manager
 B.M.
 Drawn
 B.M., R.S., S.K.
 Job No.
 27-1052
 Scale
 1" = 10'-0"

Drawing No.
L301

TORTI GALLAS AND PARTNERS, INC.

File: P:\27-1052\WestlawnPhase2\LD\VP_050_000\050_000.dwg Layout: L302 User: stier Plotter: Sep 30, 2016 - 11:41 am

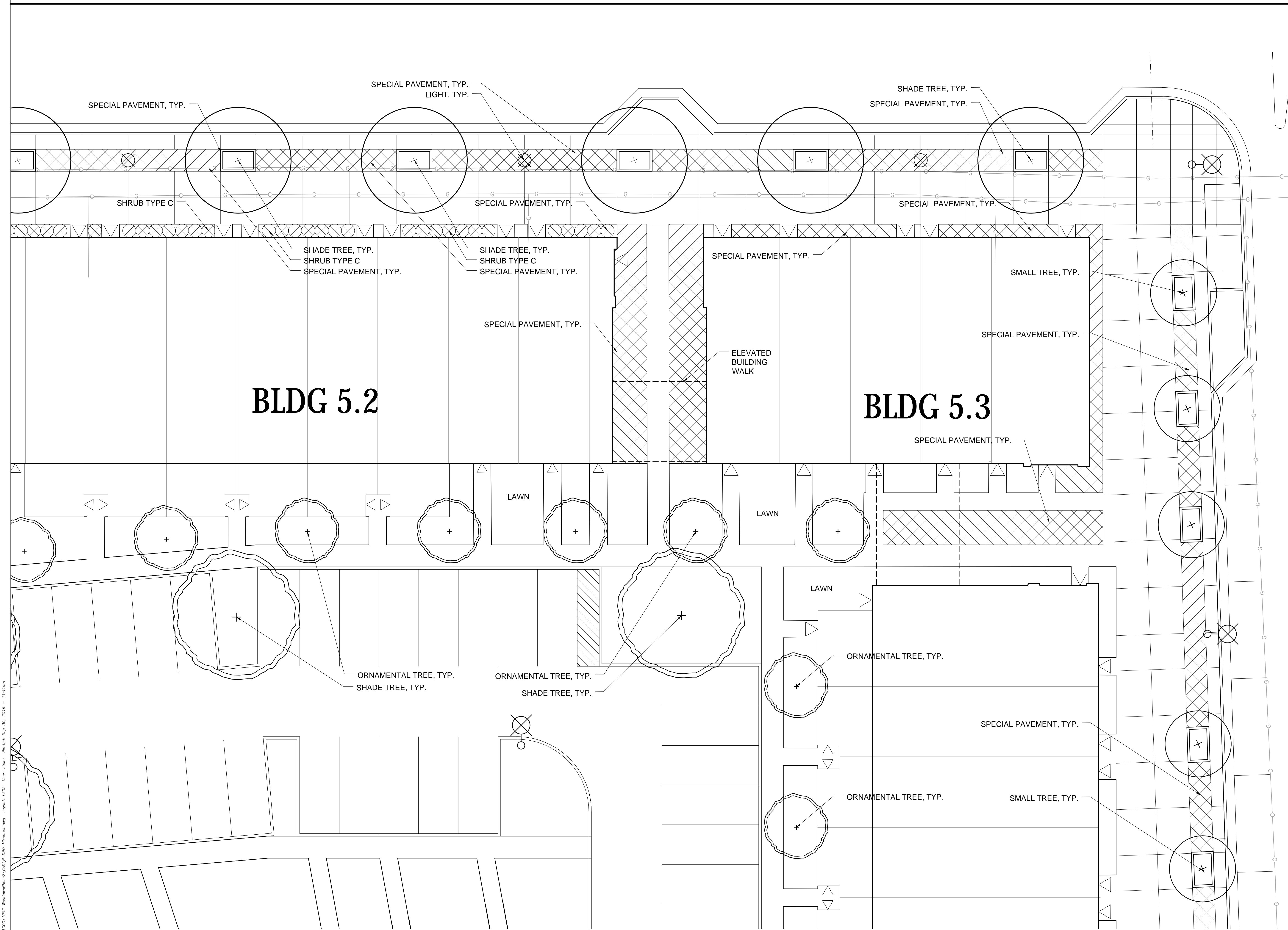

WESTLAWN GARDENS PHASE II
6331 W Silver Spring Dr
MILWAUKEE WI 53218
Owner
Housing Authority of the City of Milwaukee
414.286.3629
Architect
Torti Gallas and Partners, Inc.
1300 Spring Street, 4th Floor
Silver Spring, MD 20910
301.588.4800
www.tortigallas.com

Local Architect
Quorum Architects
414.265.9265

Local Architect
Eppstein Uhen Architects
414.271.5350

Structural Engineer:
R.A. Smith National
262.317.3279

MEP Engineers:
Thunderbird Engineering, Inc.
414.352.2211

IBC Engineering Services, Inc.
262.549.1190

Civil Engineer:
R.A. Smith National
262.522.4416

Landscape Architect:
AVRES ASSOCIATES
608.255.0800

Issue
No. Date

Revisions
No. Date

Typical Mixed Use

Date
Principal In Charge
D.W.
Project Planner
Project Landscape Architect
B.M.
Project Manager
B.M.
Drawn
B.M., R.S., S.K.
Job No.
27-1052
Scale
1" = 10'-0"

Drawing No.
L302

TORTI GALLAS AND PARTNERS, INC. WESTLAWN gardens, phase II

File: P:\27-1052_MilwaukeePhase2\GIS\VP_DPS_Milwaukee.dwg Layout: L303 User: stiber Plotter: Sep 30, 2016 11:45am

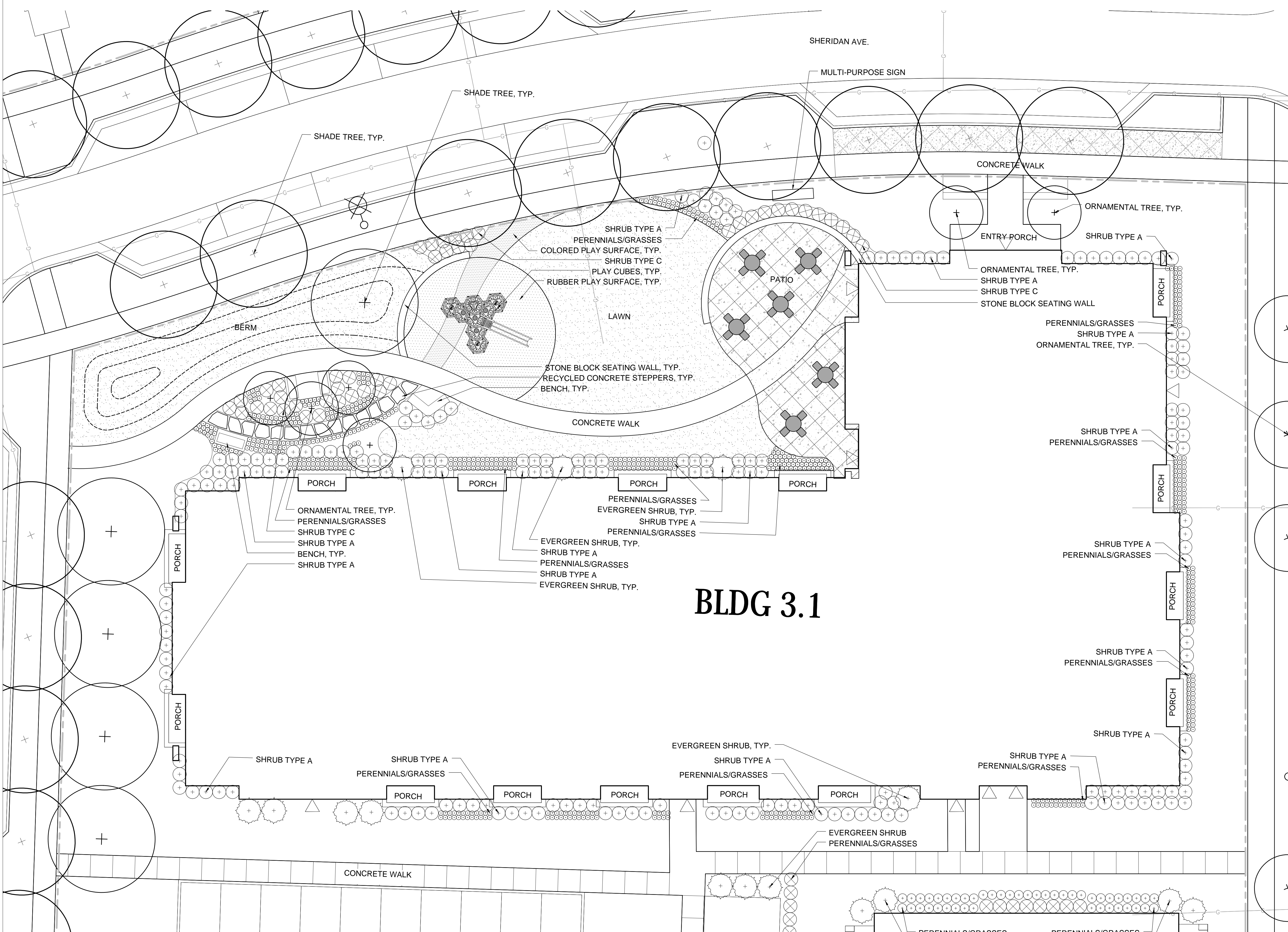

BLDG 3.1

WESTLAWN GARDENS PHASE II
 6331 W Silver Spring Dr
 MILWAUKEE WI 53218

Owner
 Housing Authority of the City of Milwaukee
 414.286.3629

Architect
 Torti Gallas and Partners, Inc.
 1300 Spring Street, 4th Floor
 Silver Spring, MD 20910
 301.588.4800
 www.tortigallas.com

Local Architect
 Quorum Architects
 414.265.9265

Local Architect
 Eppstein Uhen Architects
 414.271.5350

Structural Engineer:
 R.A. Smith National
 262.317.3279

MEP Engineers:
 Thunderbird Engineering, Inc.
 414.352.2211

IBC Engineering Services, Inc.
 262.549.1190

Civil Engineer:
 R.A. Smith National
 262.522.4416

Landscape Architect:
 AVRES ASSOCIATES
 608.255.0800

Issue

No.	Date

Revisions

No.	Date

Typical Mixed Use

Date
 Principal In Charge
 D.W.
 Project Planner

Project Landscape Architect
 B.M.
 Project Manager
 B.M.
 Drawn
 B.M., R.S., S.K.
 Job No.
 27-1052
 Scale
 1" = 10'-0"

Drawing No.
L303

TORTI GALLAS AND PARTNERS, INC. WESTLAWN gardens, phase II

File: P:\27-1052\WestlawnPhase2\LD34\VP_050_00000.dwg Layout: LD34 User: stalin Plotter: Sep 30, 2016 11:42am

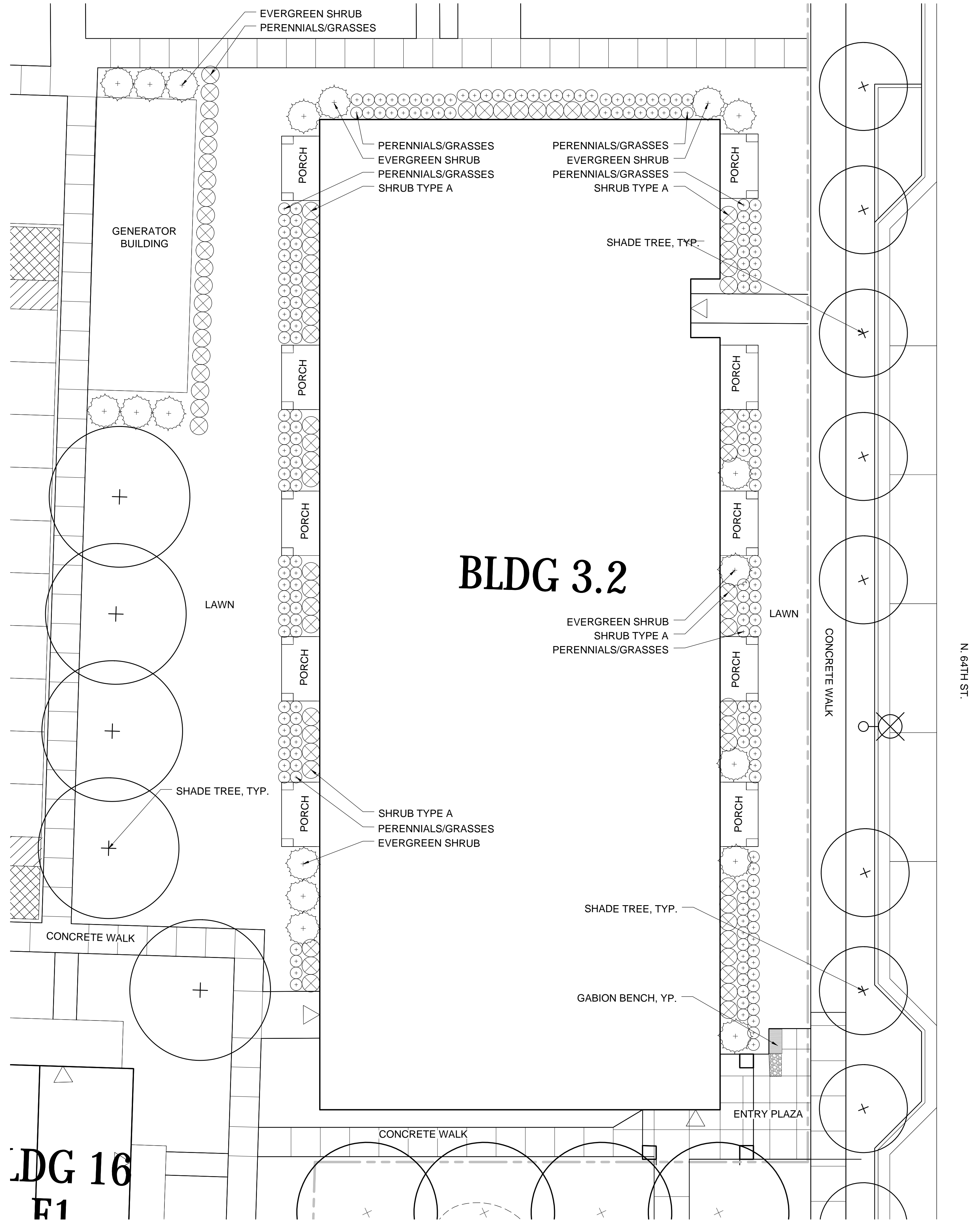

WESTLAWN GARDENS PHASE II

6331 W Silver Spring Dr
MILWAUKEE WI 53218

Owner
Housing Authority of the City of Milwaukee
414.286.3629

Architect
Torti Gallas and Partners, Inc.
1300 Spring Street, 4th Floor
Silver Spring, MD 20910
301.588.4800
www.tortigallas.com

Local Architect
Quorum Architects
414.265.9265

Local Architect
Eppstein Uhen Architects
414.271.5350

Structural Engineer:
R.A. Smith National
262.317.3279

MEP Engineers:
Thunderbird Engineering, Inc.
414.352.2211

IBC Engineering Services, Inc.
262.549.1190

Civil Engineer:
R.A. Smith National
262.522.4416

Landscape Architect:
AVRES ASSOCIATES
608.255.0800

Issue

No.	Date

Revisions

No.	Date

Typical Mixed Use

Date
Principal In Charge
D.W.
Project Planner
Project Landscape Architect
B.M.
Project Manager
B.M.
Drawn
B.M., R.S., S.K.
Job No.
27-1052
Scale
1" = 10'-0"

Drawing No.
L304

TORTI GALLAS AND PARTNERS, INC. WESTLAWN gardens, phase II

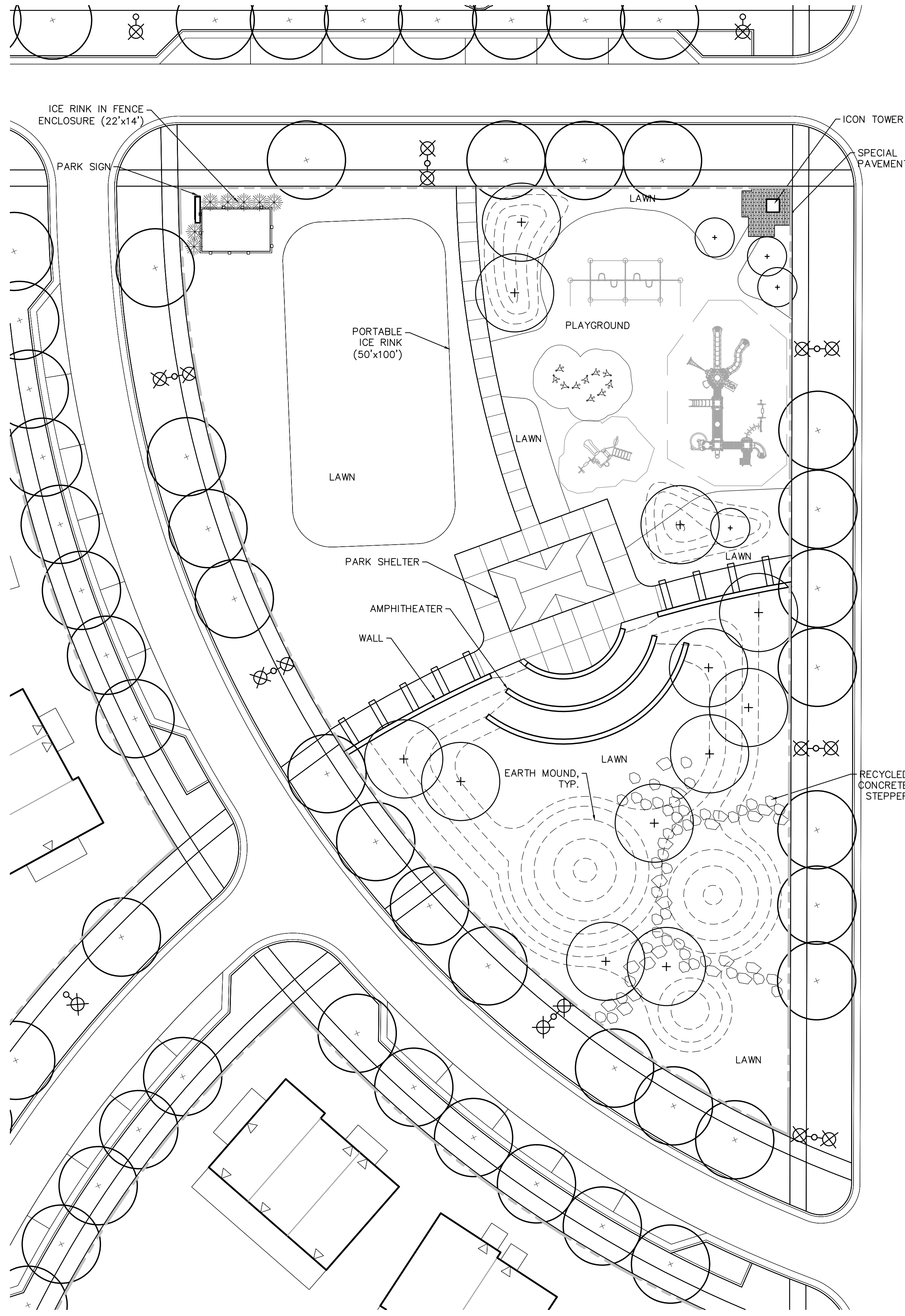

NEIGHBORHOOD PARK ENLARGEMENT

SCALE: 1"=10'-0"

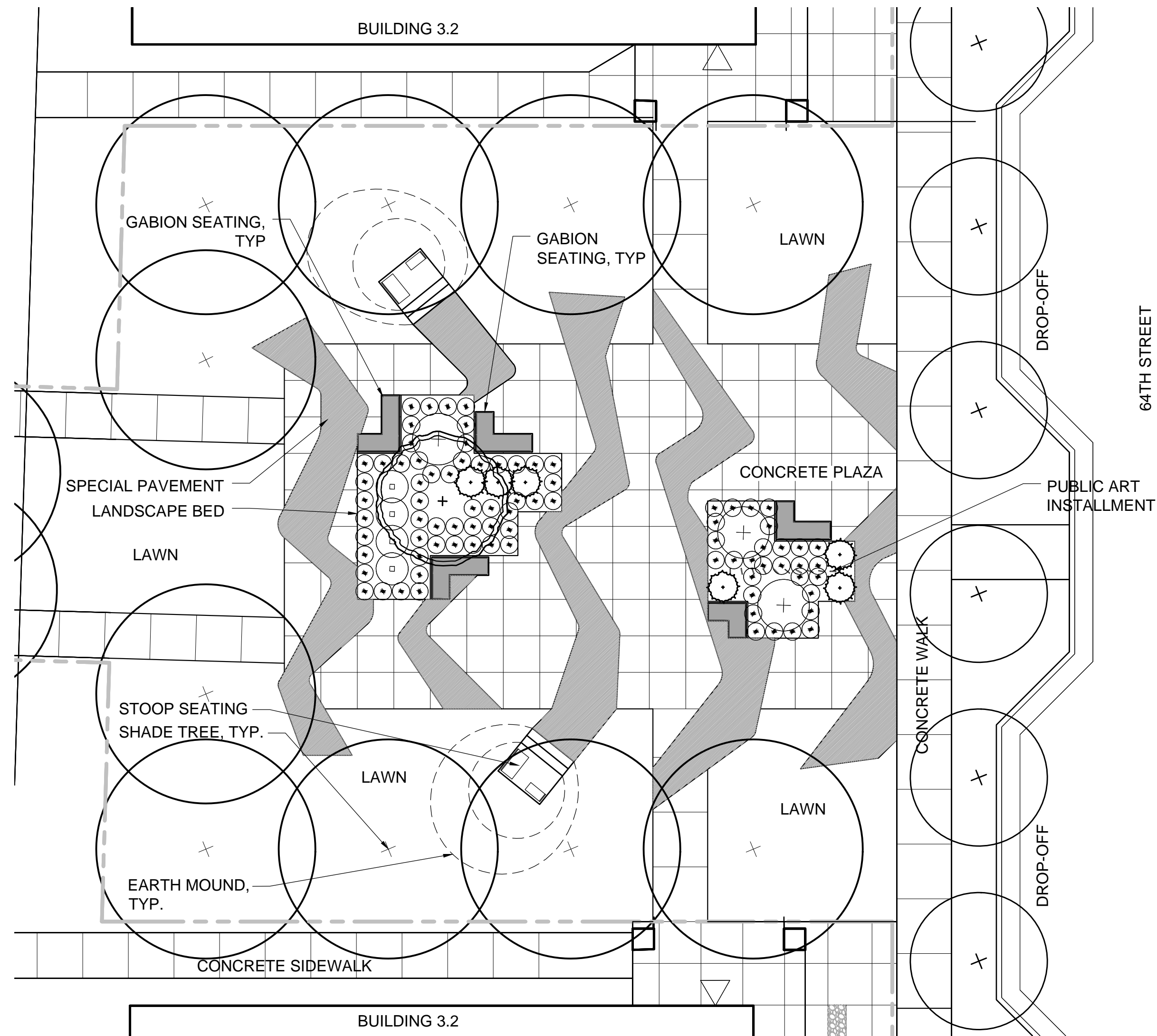

EAST PLAZA ENLARGEMENT

SCALE: 1"=10'-0"

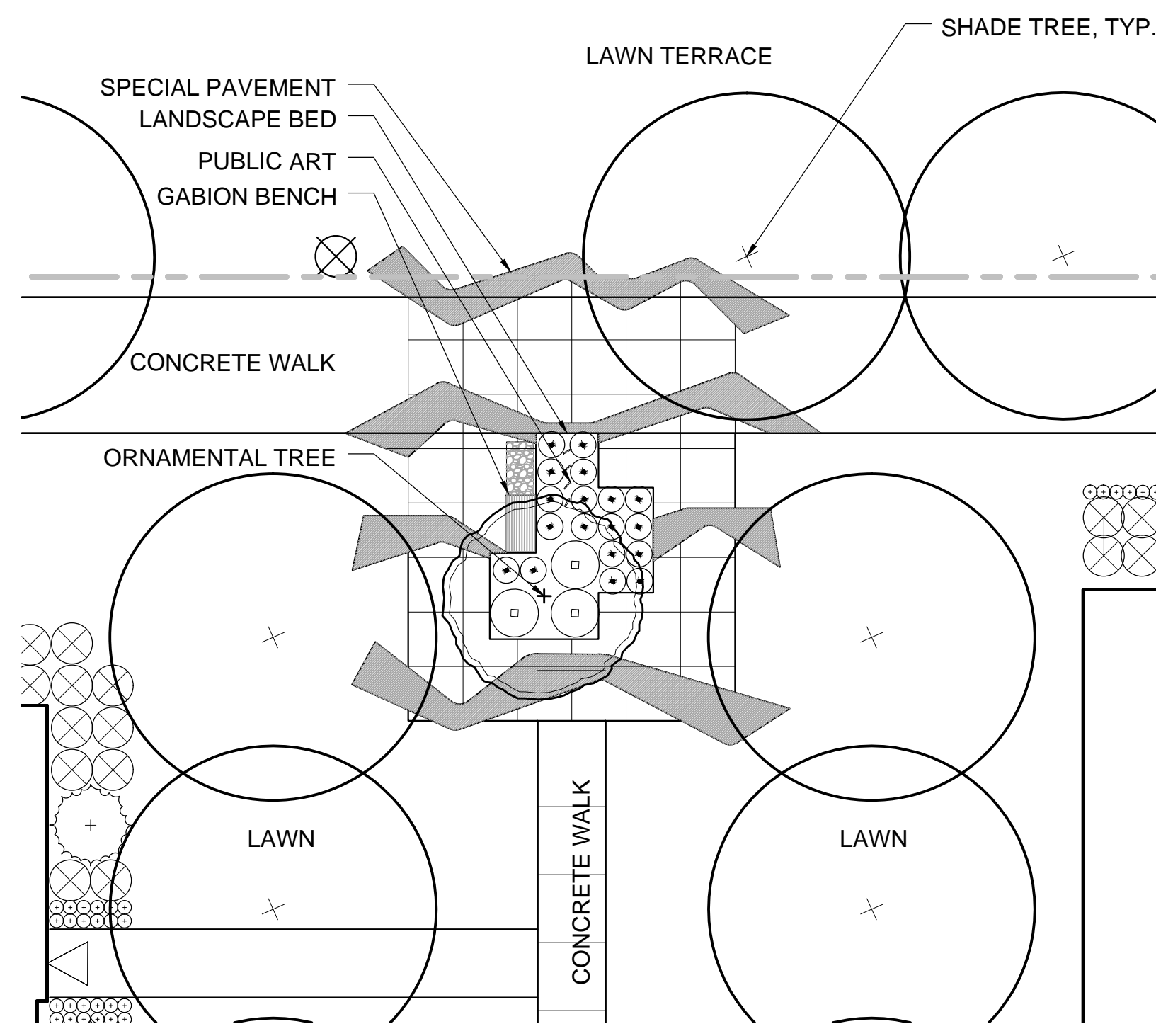

NORTH PLAZA ENLARGEMENT

SCALE: 1"=10'-0"

WESTLAWN GARDENS PHASE II

6331 W Silver Spring Dr
MILWAUKEE WI 53218

Owner
Housing Authority of the City of Milwaukee
414.286.3629

Architect
Torti Gallas and Partners, Inc.
1300 Spring Street, 4th Floor
Silver Spring, MD 20910
301.588.4800
www.tortigallas.com

Local Architect
Quorum Architects
414.265.9265

Local Architect
Eppstein Uhen Architects
414.271.5350

Structural Engineer:
R.A. Smith National
262.317.3279

MEP Engineers:
Thunderbird Engineering, Inc.
414.352.2211

IBC Engineering Services, Inc.
262.549.1190

Civil Engineer:
R.A. Smith National
262.522.4416

Landscape Architect:
AVRES ASSOCIATES
608.255.0800

Issue

No. Date

Revisions

No. Date

Typical Open Space

Date
Principal In Charge
D.W.
Project Planner

Project Landscape Architect
B.M.
Project Manager
B.M.
Drawn
B.M., R.S., S.K.
Job No.
27-1052
Scale
1" = 10'-0"

Drawing No.
L400

File: P:\27-1052 WestlawnPhase2\CD\VP_DPL_Typtical_OpenSpace.dwg Layout: L400 User: slair Plotter: Sep 30, 2016 11:42am

TORTI GALLAS AND PARTNERS, INC.

WESTLAWN gardens, phase II

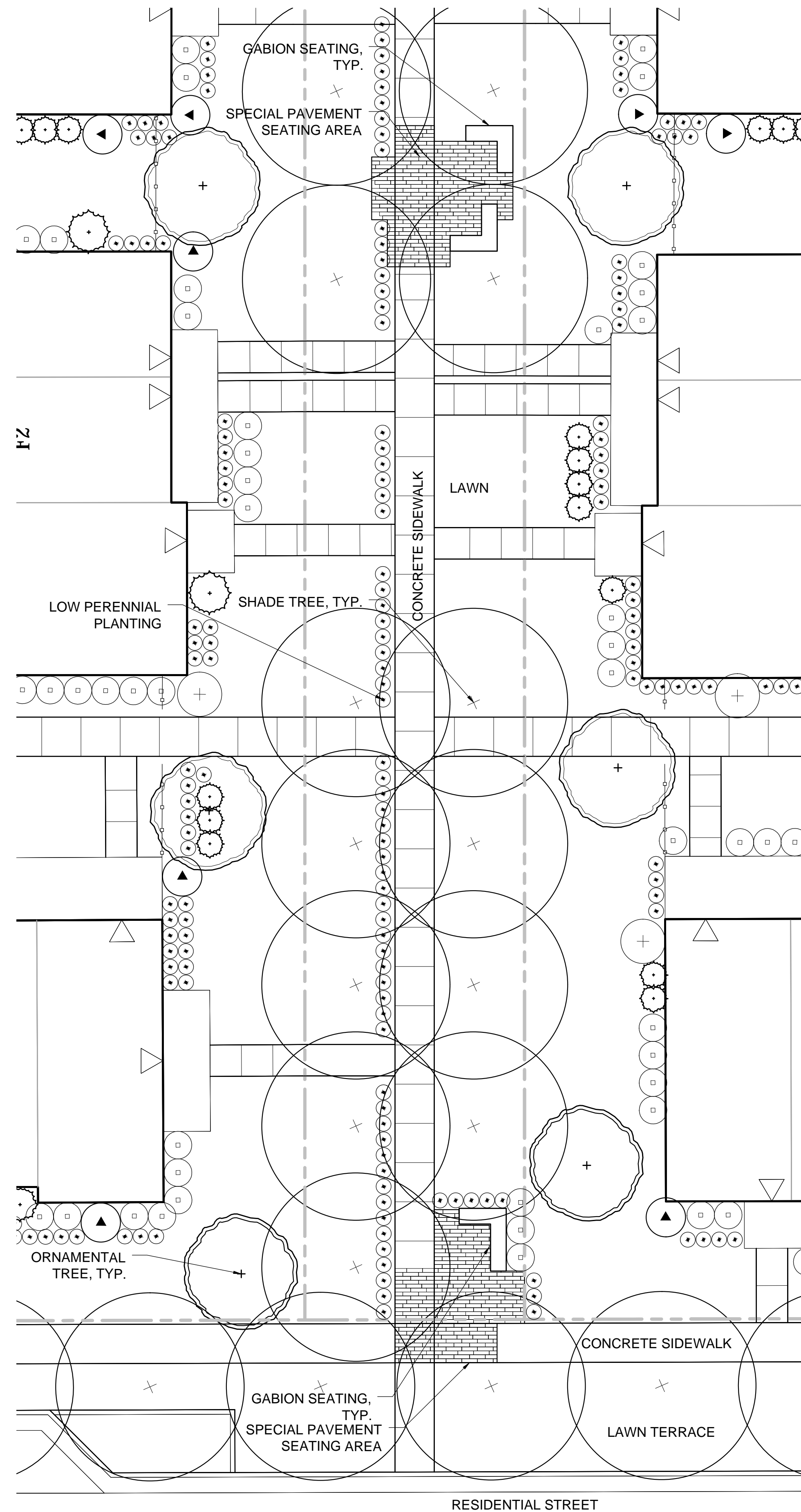

TYPICAL NORTH/SOUTH MEWS ENLARGEMENT

SCALE: 1"=10'-0"

TYPICAL EAST/WEST MEWS ENLARGEMENT

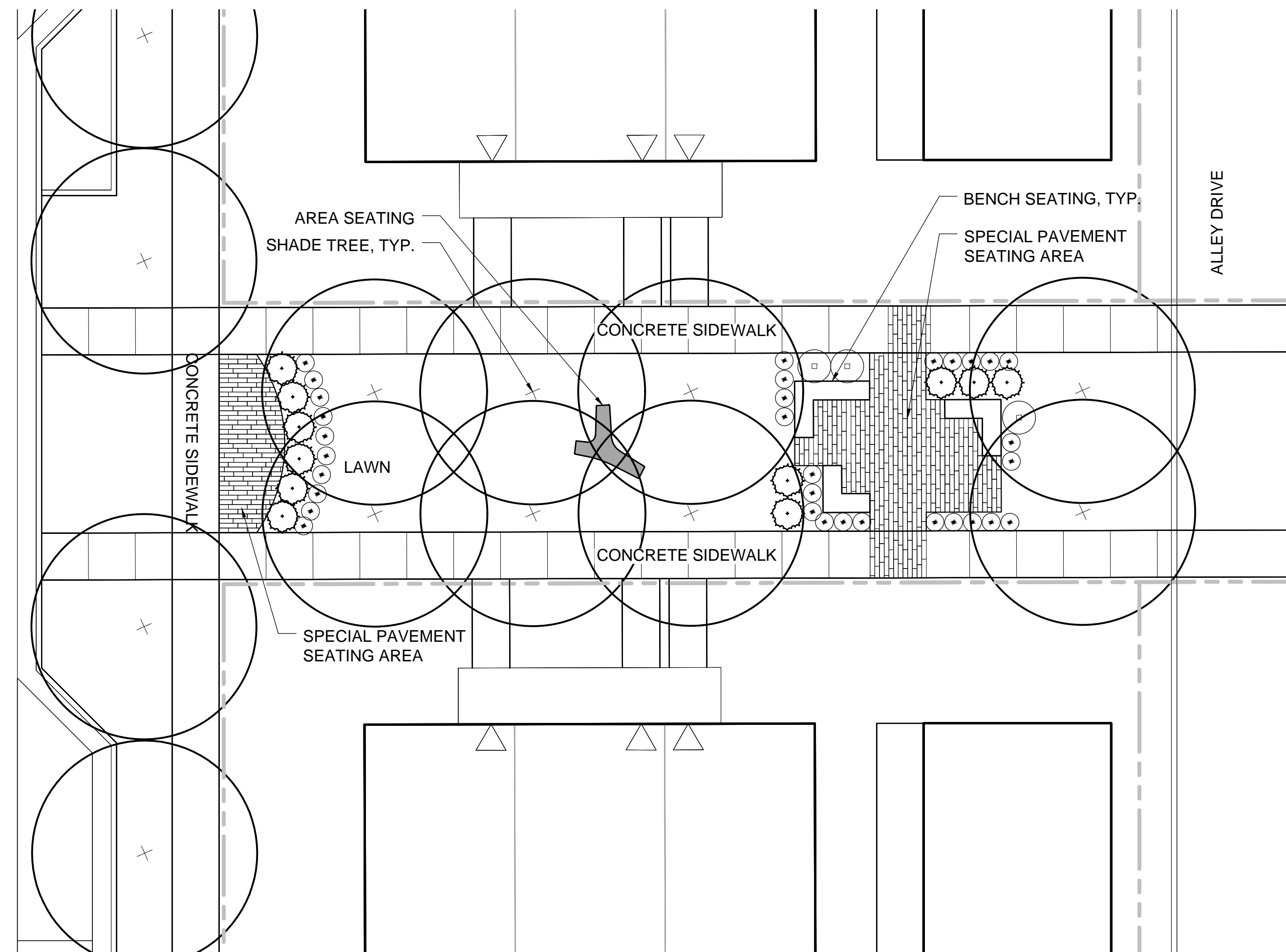

SCALE: 1"=10'-0"

File: P:\27-1052-WestlawnPhase2\CD\VP_050_Typhical_OpenSpace.dwg Layout: L401 User: slater Plotter: Sep 30, 2016 11:45am

WESTLAWN GARDENS PHASE II

6331 W Silver Spring Dr
MILWAUKEE WI 53218

Owner
Housing Authority of the City of Milwaukee
414.286.3629

Architect
Torti Gallas and Partners, Inc.
1300 Spring Street, 4th Floor
Silver Spring, MD 20910
301.588.4800
www.tortigallas.com

Local Architect
Quorum Architects
414.265.9265

Local Architect
Eppstein Uhen Architects
414.271.5350

Structural Engineer:
R.A. Smith National
262.317.3279

MEP Engineers:
Thunderbird Engineering, Inc.
414.352.2211

IBC Engineering Services, Inc.
262.549.1190

Civil Engineer:
R.A. Smith National
262.522.4416

Landscape Architect:
AVRES ASSOCIATES
608.255.0800

Issue

No.	Date

Revisions

No.	Date

Typical Open Space

Date
Principal In Charge
D.W.
Project Planner
Project Landscape Architect
B.M.
Project Manager
B.M.
Drawn
B.M., R.S., S.K.
Job No.
27-1052
Scale
1" = 10'-0"

Drawing No.
L401

TORTI GALLAS AND PARTNERS, INC.



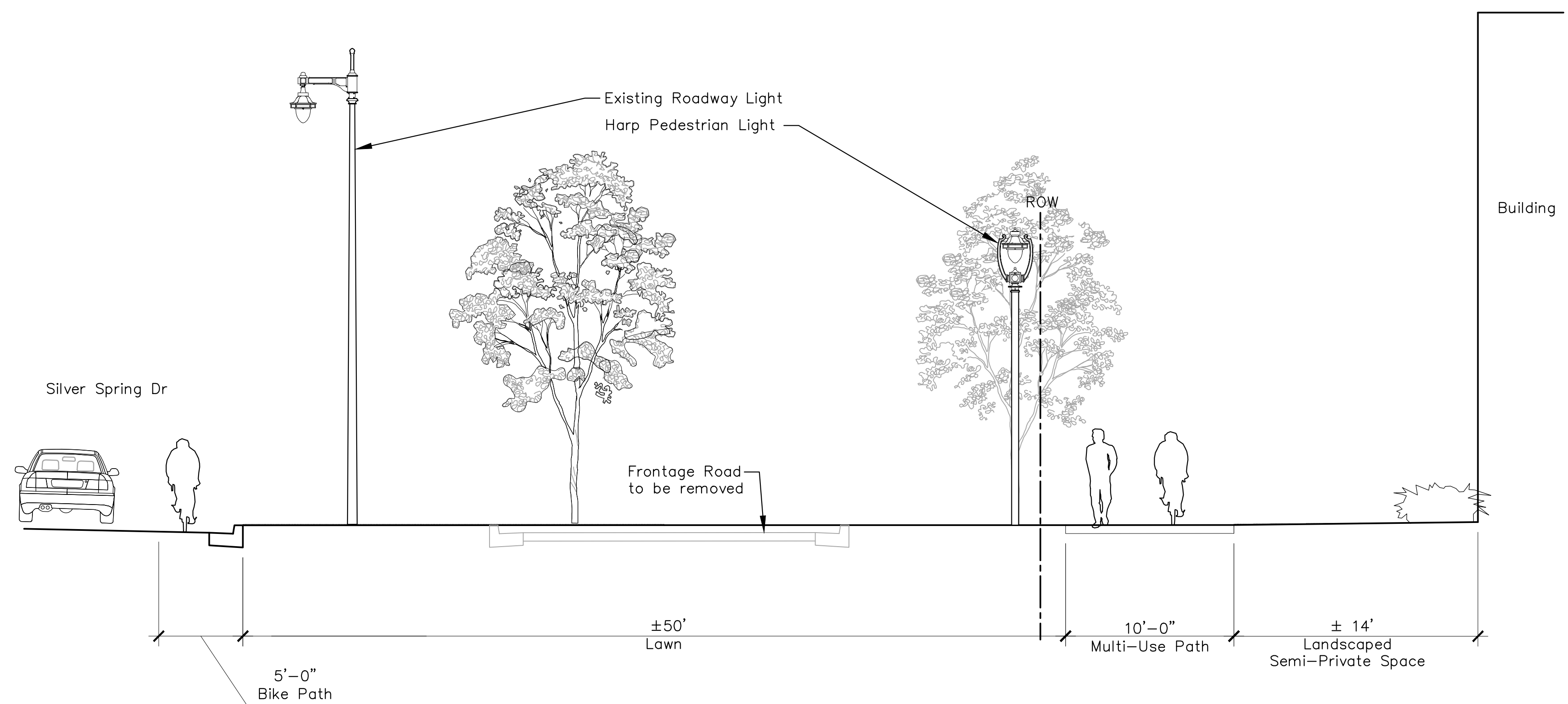
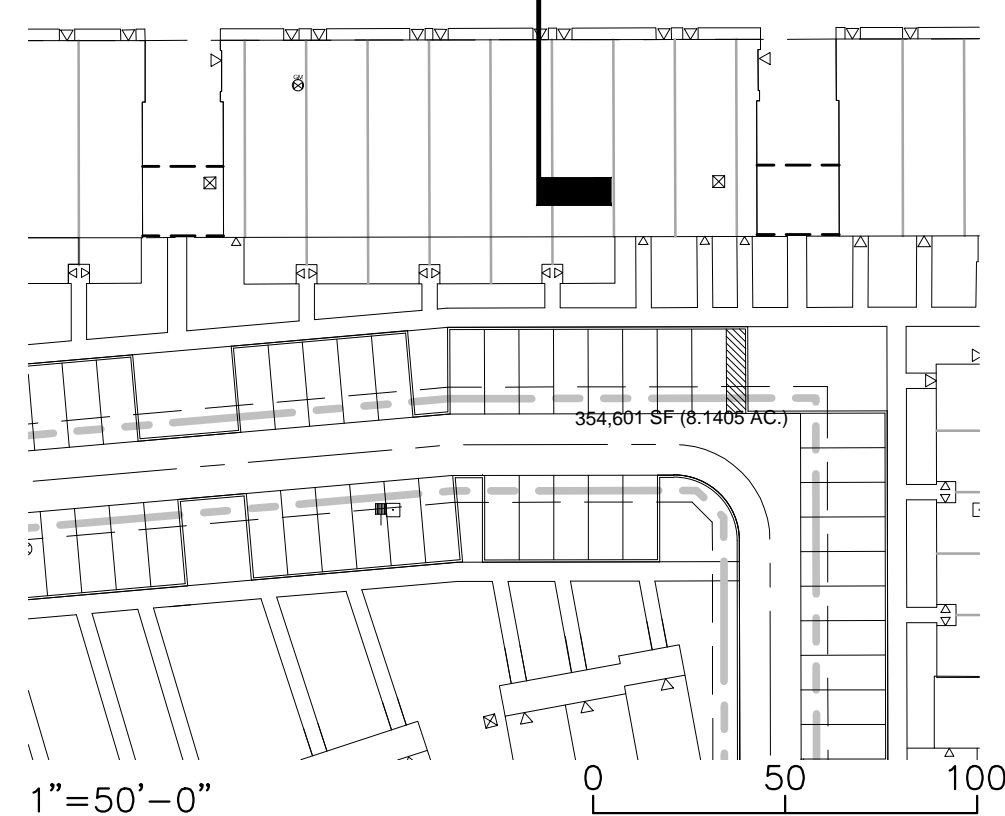
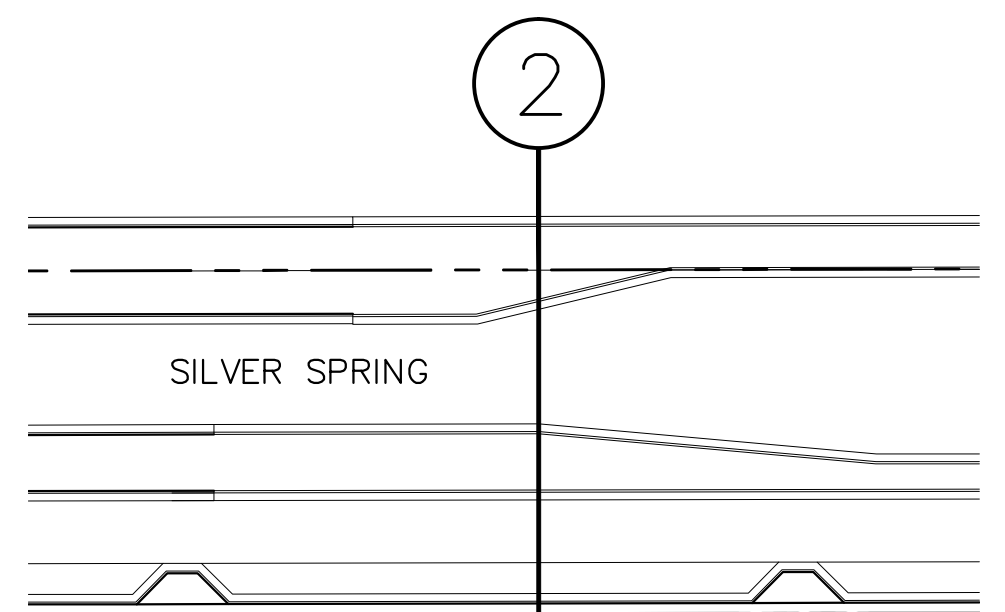
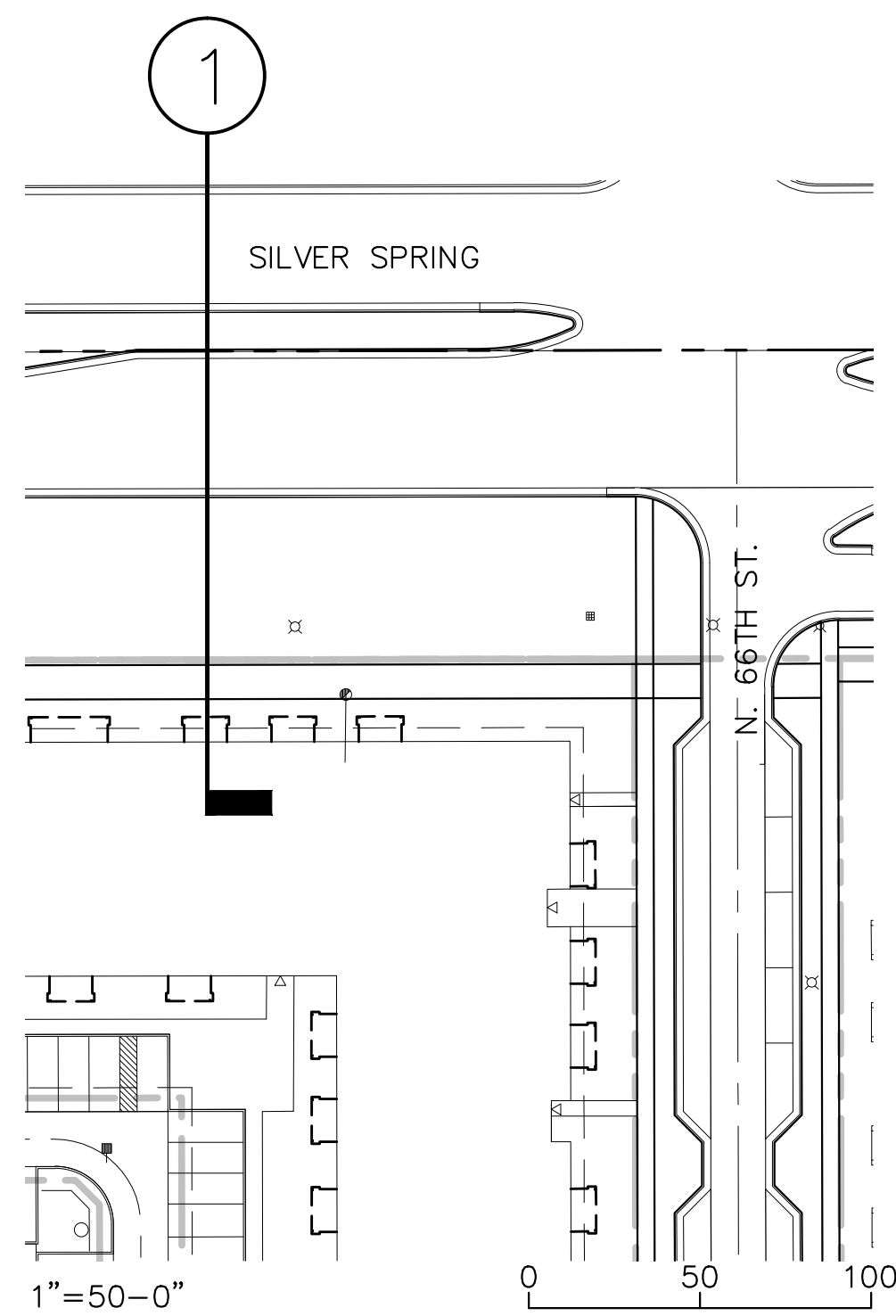

1 STREETScape SECTION
BETWEEN 66ND AND 68TH

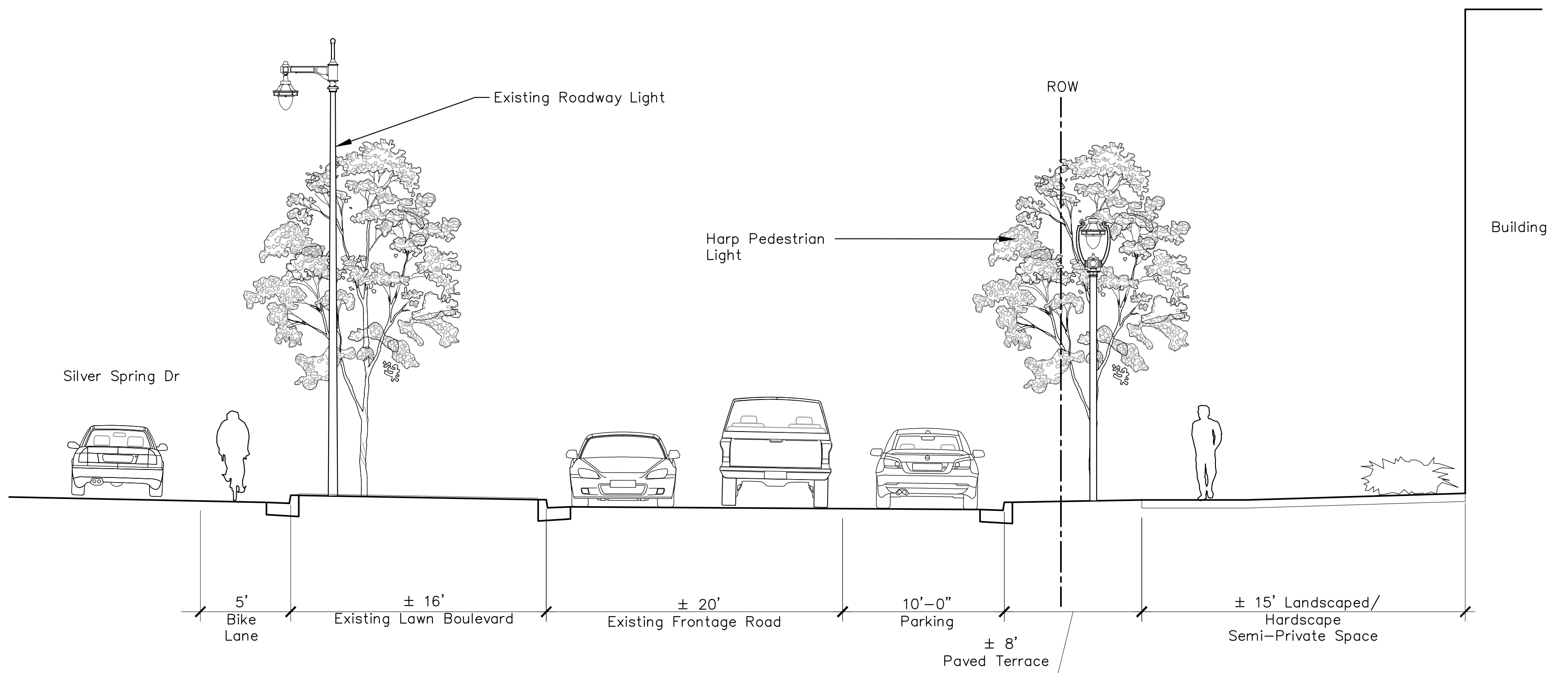

2 STREETScape SECTION
BETWEEN 64ND AND 66TH

**WESTLAWN
GARDENS
PHASE II**

6331 W Silver Spring Dr
MILWAUKEE WI 53218

Owner
Housing Authority of
the City of Milwaukee
414.286.3629

Architect
Torti Gallas
and Partners, Inc.
1300 Spring Street, 4th Floor
Silver Spring, MD 20910
301.588.4800
www.tortigallas.com

Local Architect
Quorum Architects
414.265.9265

Local Architect
Eppstein Uhen
Architects
414.271.5350

Structural Engineer:
R.A. Smith National
262.317.3279

MEP Engineers:
Thunderbird Engineering, Inc.
414.352.2211

IBC Engineering Services, Inc.
262.549.1190

Civil Engineer:
R.A. Smith National
262.522.4416

Landscape Architect:
AVRES
ASSOCIATES
608.255.0800

Issue

No.	Date

Revisions

No.	Date
▲	
▲	
▲	
▲	
▲	
▲	
▲	
▲	
▲	
▲	
▲	

Typical Sections

Date
Principal In Charge
D.W.
Project Planner
Project Landscape Architect
B.M.
Project Manager
B.M.
Drawn
B.M., R.S., S.K.
Job No.
27-1052
Scale
1" = 5'-0"

Drawing No.
L500

WESTLAWN GARDENS PHASE II

6331 W Silver Spring Dr
MILWAUKEE WI 53218

Owner
Housing Authority of the City of Milwaukee
414.286.3629

Architect
Torti Gallas and Partners, Inc.
1300 Spring Street, 4th Floor
Silver Spring, MD 20910
301.588.4800
www.tortigallas.com

Local Architect
Quorum Architects
414.265.9265

Local Architect
Eppstein Uhen Architects
414.271.5350

Structural Engineer:
R.A. Smith National
262.317.3279

MEP Engineers:
Thunderbird Engineering, Inc.
414.352.2211

IBC Engineering Services, Inc.
262.549.1190

Civil Engineer:
R.A. Smith National
262.522.4416

Landscape Architect:
AVRES ASSOCIATES
608.255.0800

Issue

No.	Date

Revisions

No.	Date
▲	
▲	
▲	
▲	
▲	
▲	
▲	
▲	
▲	
▲	

Typical Sections

Date
Principal In Charge
D.W.
Project Planner
Project Landscape Architect
B.M.
Project Manager
B.M.
Drawn
B.M., R.S., S.K.
Job No.
27-1052
Scale
1" = 5'-0"

Drawing No.
L501

TORTI GALLAS AND PARTNERS, INC.

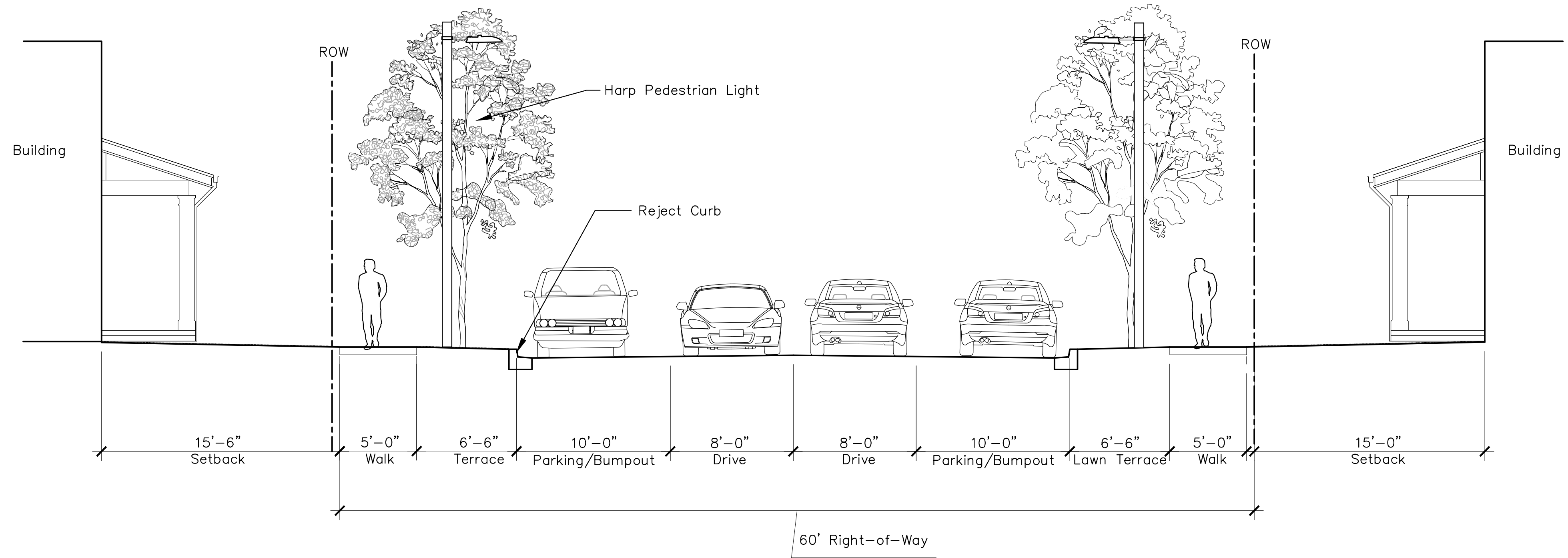
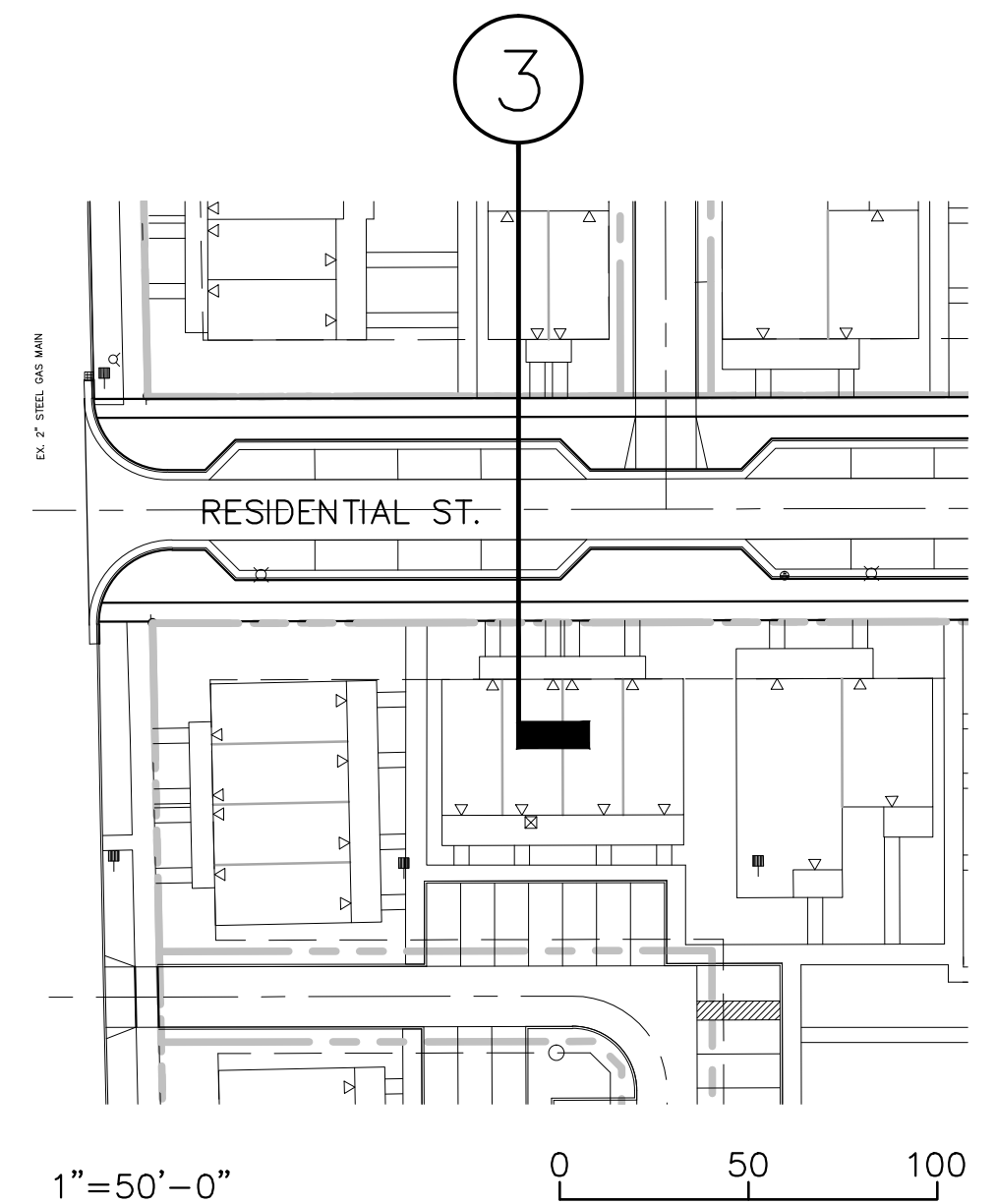

3 TYPICAL RESIDENTIAL STREET MID BLOCK

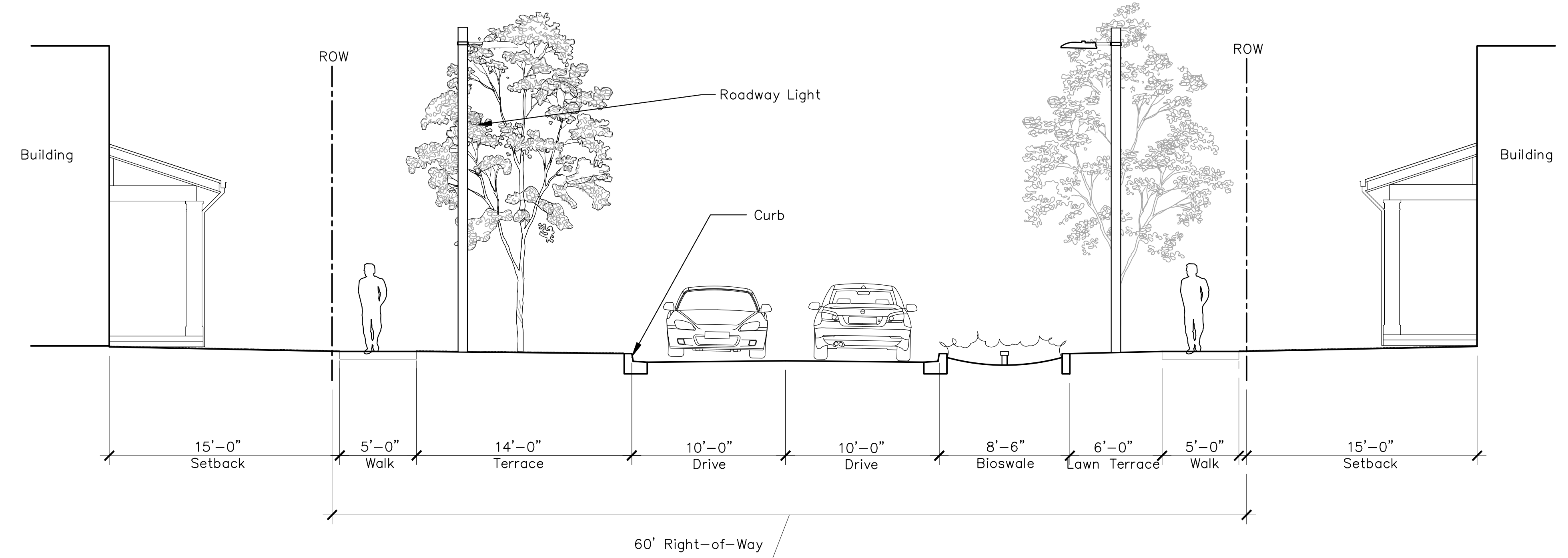
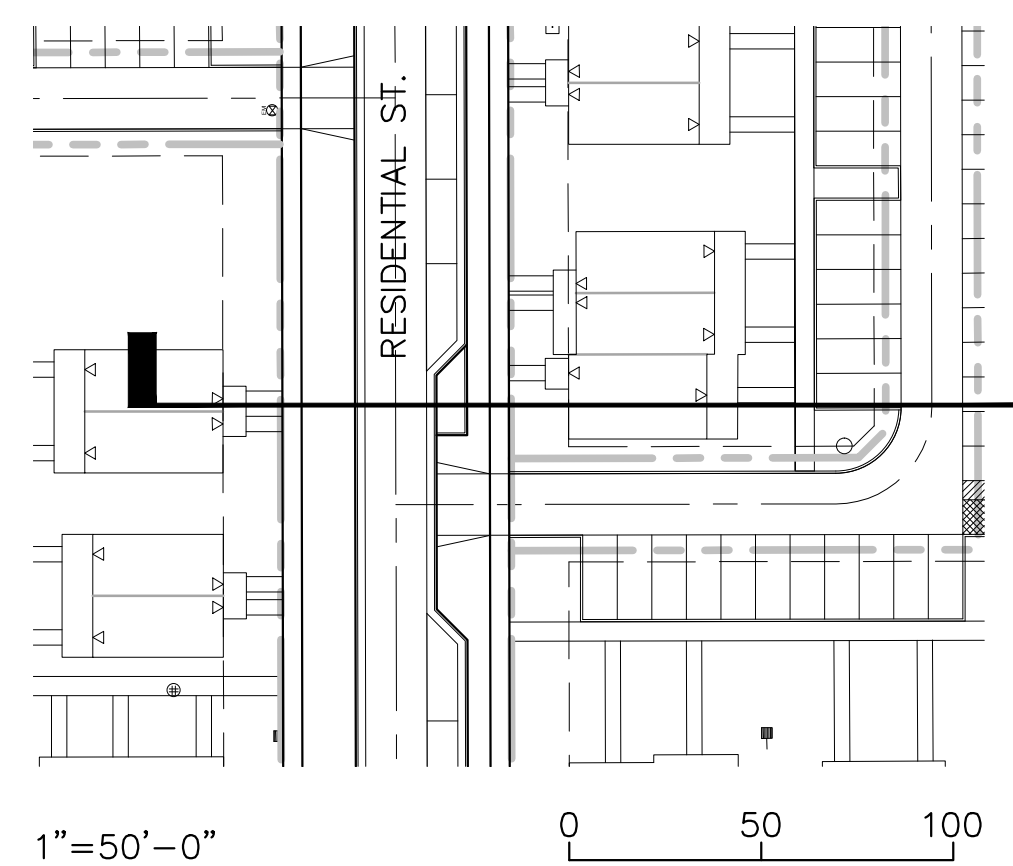

4 TYPICAL RESIDENTIAL STREET AT INTERSECTION

File: P:\27-1052_WestlawnPhase2\CD\VP_Section.dwg Layout: L501 User: stehar Plotter: Sep 30, 2016 - 11:20am

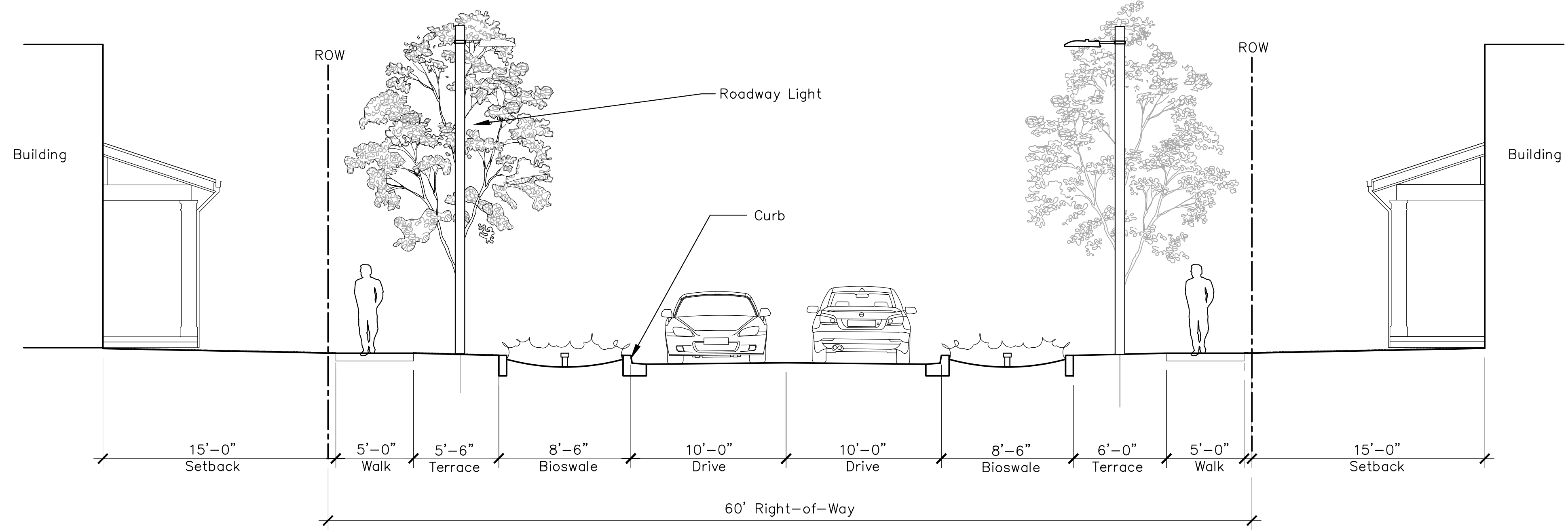
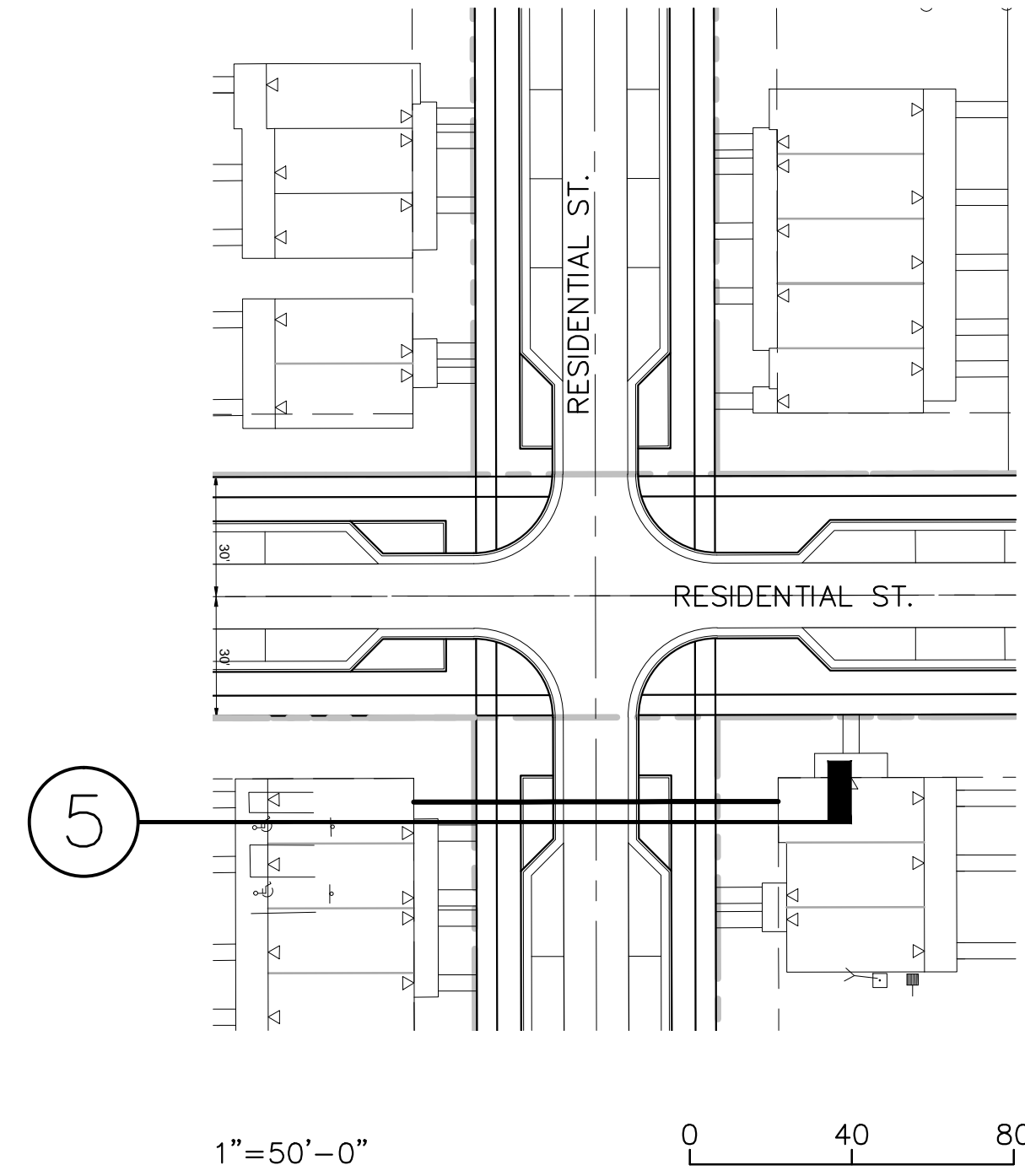

5 TYPICAL RESIDENTIAL STREET AT CORNER BUMP-OUT

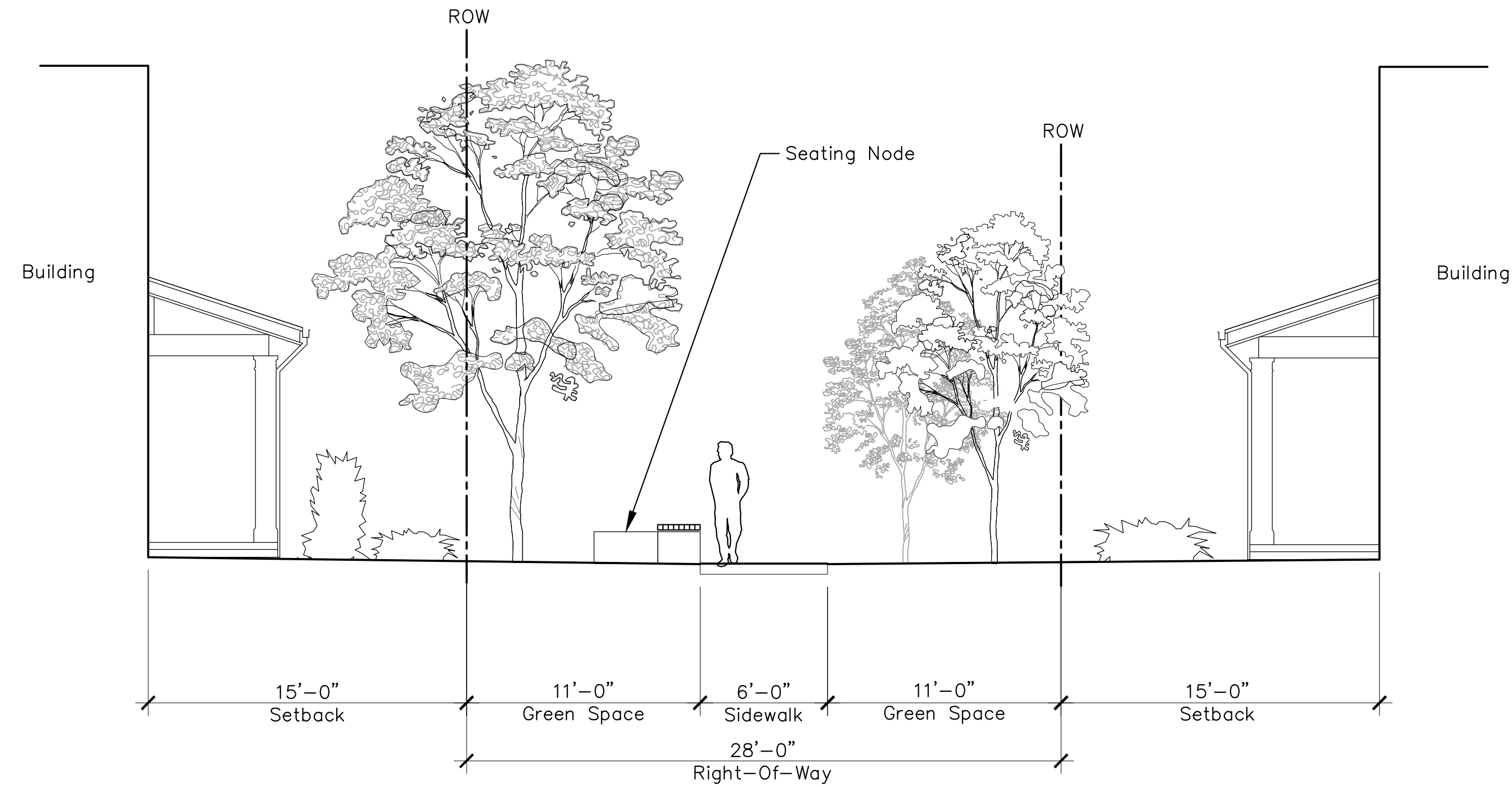
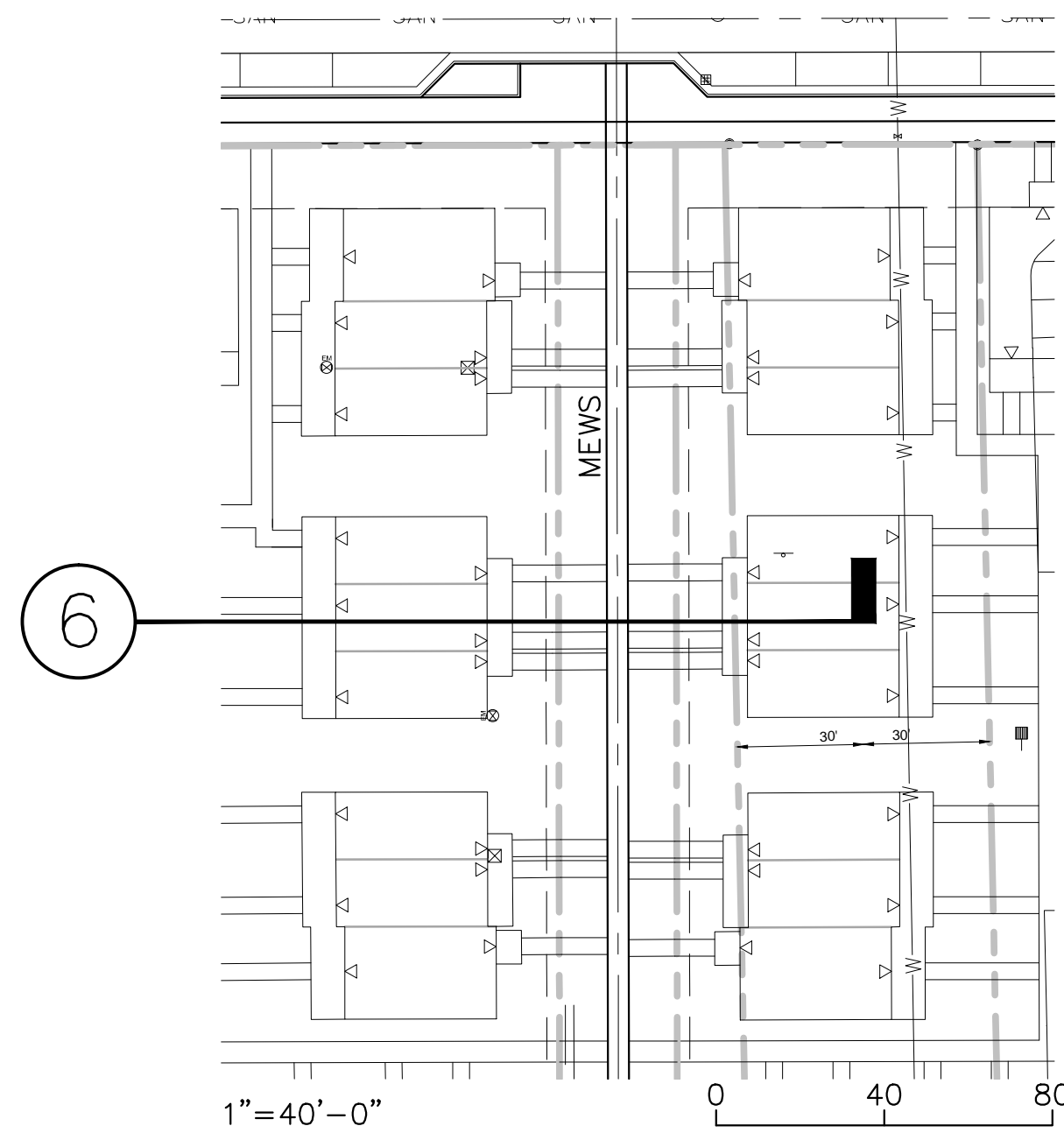

6 TYPICAL MEWS SECTION

**WESTLAWN
GARDENS
PHASE II**

6331 W Silver Spring Dr
MILWAUKEE WI 53218

Owner
Housing Authority of
the City of Milwaukee
414.286.3629

Architect
Torti Gallas
and Partners, Inc.
1300 Spring Street, 4th Floor
Silver Spring, MD 20910
301.588.4800
www.tortigallas.com

Local Architect
Quorum Architects
414.265.9265

Local Architect
Eppstein Uhen
Architects
414.271.5350

Structural Engineer:
R.A. Smith National
262.317.3279

MEP Engineers:
Thunderbird Engineering, Inc.
414.352.2211

IBC Engineering Services, Inc.
262.549.1190

Civil Engineer:
R.A. Smith National
262.522.4416

Landscape Architect:
AVRES
ASSOCIATES
608.255.0800

Issue

No.	Date

Revisions

No.	Date

Typical Sections

Date
Principal In Charge
D.W.
Project Planner

Project Landscape Architect
B.M.
Project Manager
B.M.
Drawn
B.M., R.S., S.K.
Job No.
27-1052
Scale
1" = 5'-0"

Drawing No.
L502

WESTLAWN GARDENS PHASE II

6331 W Silver Spring Dr
MILWAUKEE WI 53218

Owner
 Housing Authority of the City of Milwaukee
414.286.3629

Architect
 Torti Gallas and Partners, Inc.
1300 Spring Street, 4th Floor
Silver Spring, MD 20910
301.588.4800
www.tortigallas.com

Local Architect
 Quorum Architects
414.265.9265

Local Architect
 Eppstein Uhen Architects
414.271.5350

Structural Engineer:
[R.A. Smith National](#)
262.317.3279

MEP Engineers:
 Thunderbird Engineering, Inc.
414.352.2211

IBC Engineering Services, Inc.
262.549.1190

Civil Engineer:
[R.A. Smith National](#)
262.522.4416

Landscape Architect:
 AVRES ASSOCIATES
608.255.0800

Issue
 No. Date

Revisions
 No. Date

**Landscape Buffering/
Fencing**

Date
 Principal In Charge
D.W.
 Project Planner
 Project Landscape Architect
B.M.
 Project Manager
B.M.
 Drawn
B.M., R.S., S.K.
 Job No.
27-1052
 Scale
No Scale

Drawing No.
L600

WESTLAWN gardens, phase II
 TORTI GALLAS AND PARTNERS, INC.

STANDARDS THAT APPLY

Perimeter Landscape and Edge Treatment requirements borrow from current zoning district requirements in the creation of the Westlawn Planned Development District. Buffer standards and character are per attached sheet (L401) and the following descriptions. Screening strategies are delivered in both softscape (vegetation) and fencing treatments throughout the Westlawn development.

C-1:
 Trees shall be a min. 2.5" caliper (No ash/female ginkgo). Ornamental trees spaced no more than 20' apart contained within min. 10' landscape area

C-3:
 Landscape areas directly abutting public sidewalks to be separated by curb or recessed bed.

C-4:
 Residential Buffers: parking lots must be screened that are within 25' of a wholly residential area (between the parking lot and residential lot line). Where a parking area abuts an alley, no fence or wall shall be required

C-5:
 Where required, fence piers shall be a minimum 25' spacings, metal fences shall have an opacity not exceeding 50%. Masonry materials shall relate to architecture

C-6:
 Berms can substitute for required perimeter features

C-8:
 The required landscaped area may encroach into the public R/W if a masonry pier and metal fence or masonry wall is provided. Such fence/wall shall be located on the non-public portion of the landscaped area.

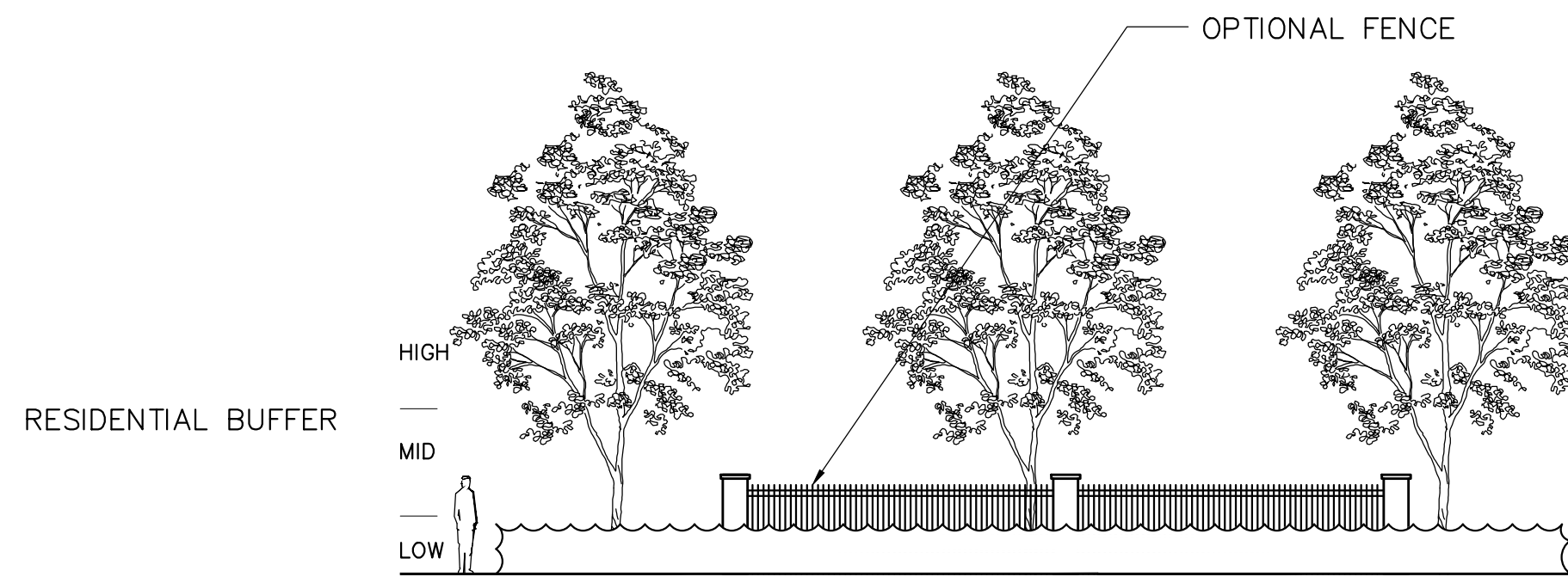

OBJECT SCREENING
 OPAQUE FENCE/LOW LEVEL
 EVERGREEN VEGETATION

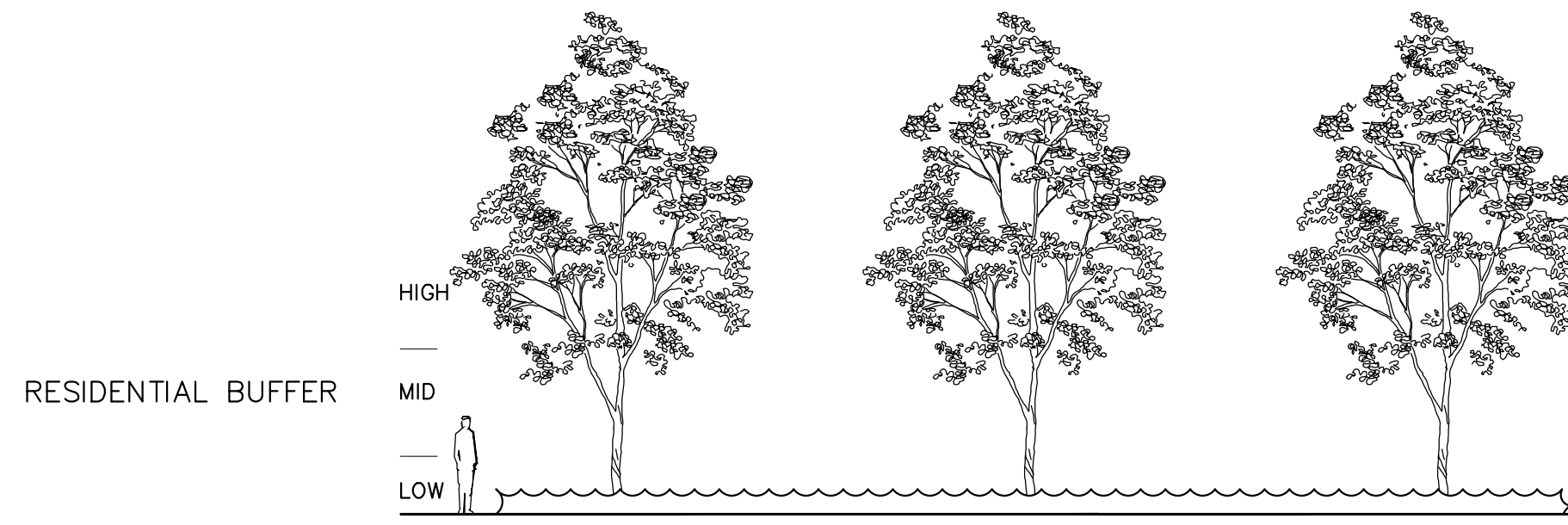

OBJECT SCREENING
 EVERGREEN VEGETATION

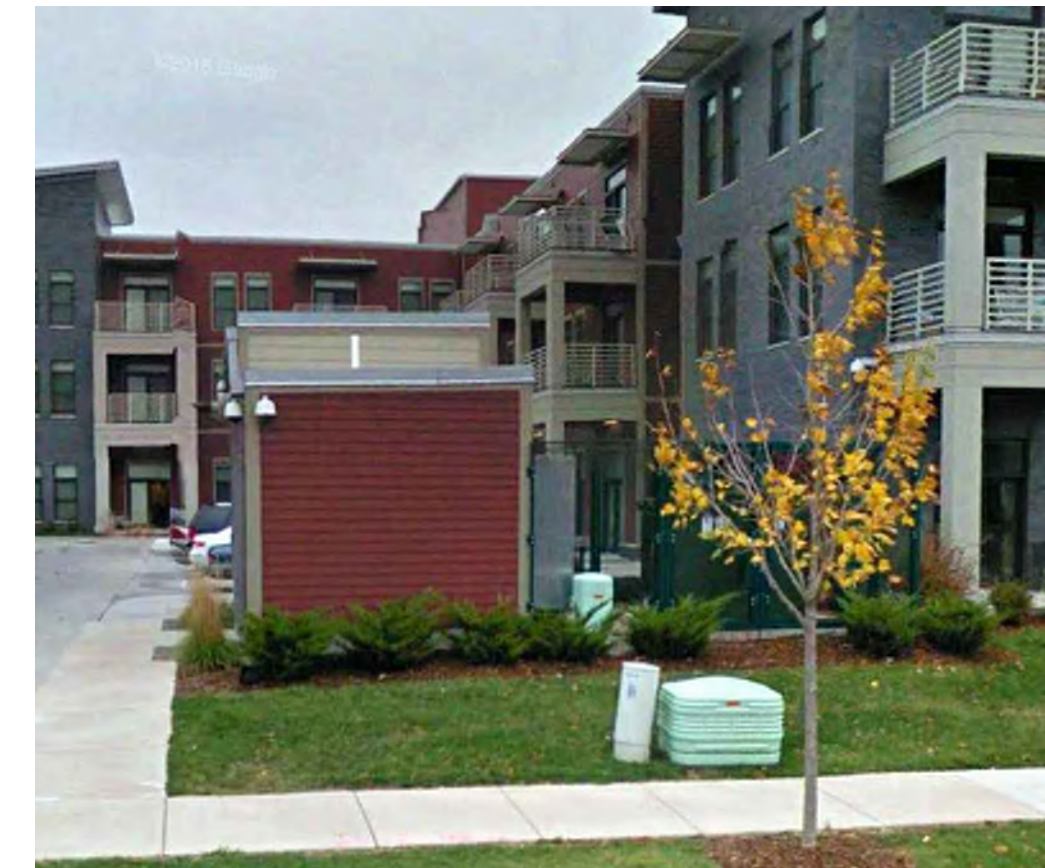

STANDARD PARKING LOT LANDSCAPING & RESIDENTIAL BUFFERING

TYPE A: STANDARD PARKING LOT LANDSCAPING*

- Regular spaced street trees
- Continuous base shrubs
- No fences/Walls required
- Eye level zone shall be kept open
- Fence or wall: >3' <6'
- Wood, Masonry, Decorative Metal only
- Deciduous street tree: 1 every 25'
- Ornamental tree: 1 every 20'
- Shrub: 3.5' maximum height
- Double staggered row of shrubs

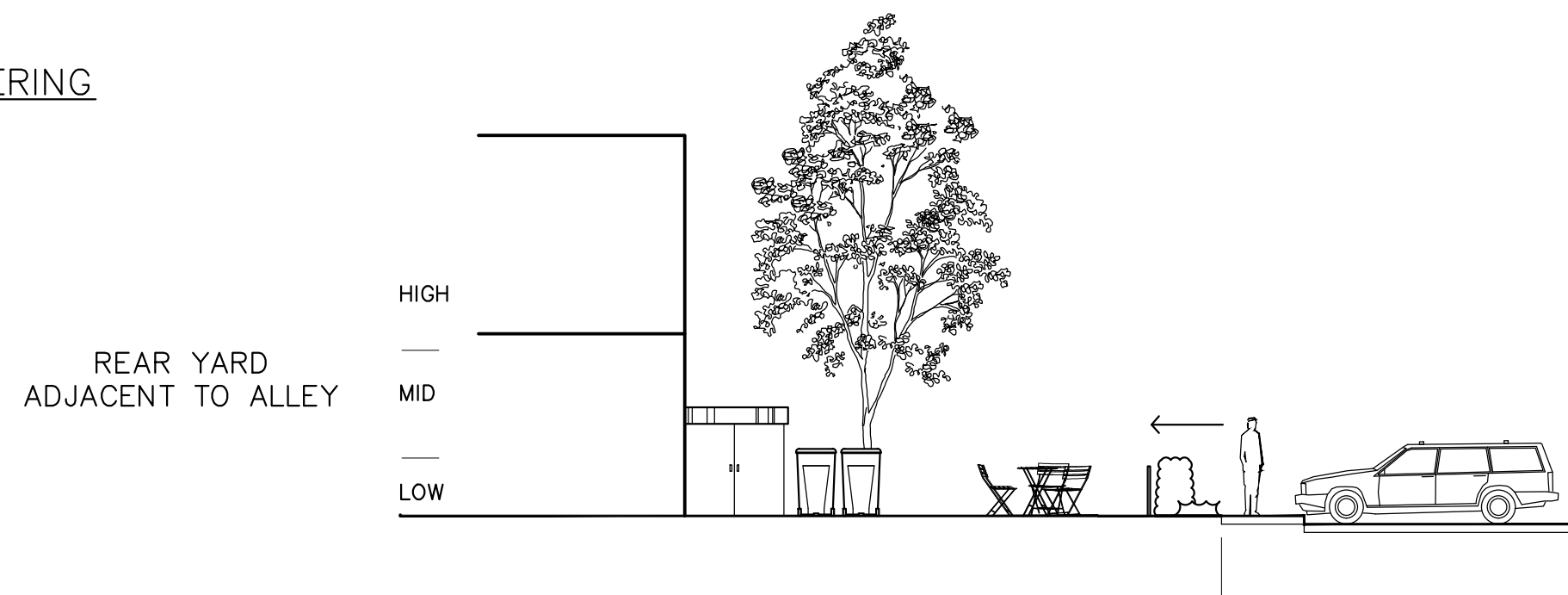

UNIT SEPARATION FENCE
 RESIDENTIAL REAR YARDS
 VINYL COATED

TYPE H: LANDSCAPING – RESIDENTIAL BUFFER*

- Separate parking from residential units
- Screen from churches, schools, apartments & non-residential uses, as well as principle use parking lots/structures
- Primarily opaque fencing
- Requires softscape when the parking lot provides parking for uses other than single or two-family dwelling units
- Fence: 6' height (up to 9'), 3'-6" when adjacent to residential front yard
- Any opaque fence type permitted
- Deciduous street tree: 1 every 25'
- Ornamental tree: 1 every 20'
- Shrub: No limit maximum height

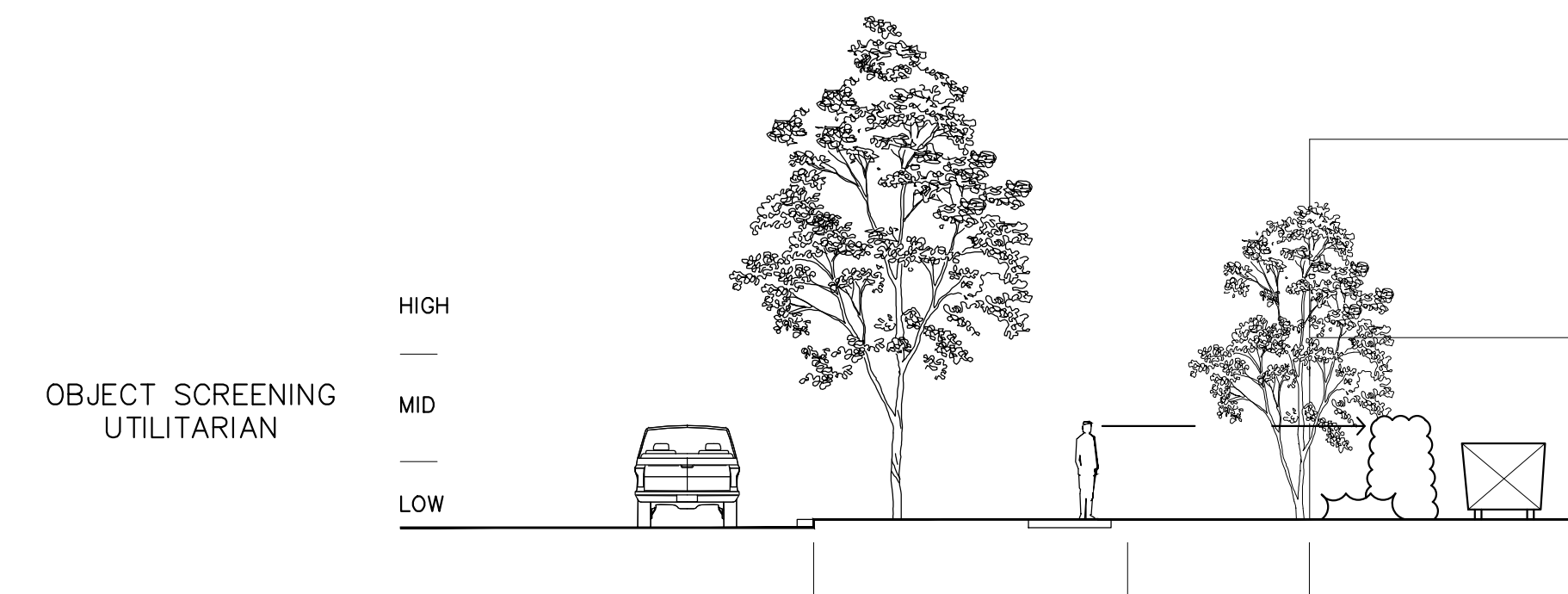

PRIVACY FENCE
 RESIDENTIAL MID-BLOCKS
 MATERIAL TBD

LANDSCAPING OBJECT SCREENING

TYPE G: LANDSCAPING – OBJECT SCREENING*

- Visually separate utilitarian objects
- Mechanical equipment, dumpsters, etc.
- No trees required
- No fence or wall required
- Required screening from 0-6' height
- Plantings to occur in low & mid levels
- Completely obscure area from street
- Fence to top of object being screened +1' (9' max.)
- Any opaque fence type permitted
- Deciduous street tree: Not required
- Ornamental tree: 1 every 20'
- Shrub: 6' size at planting, no limit maximum height

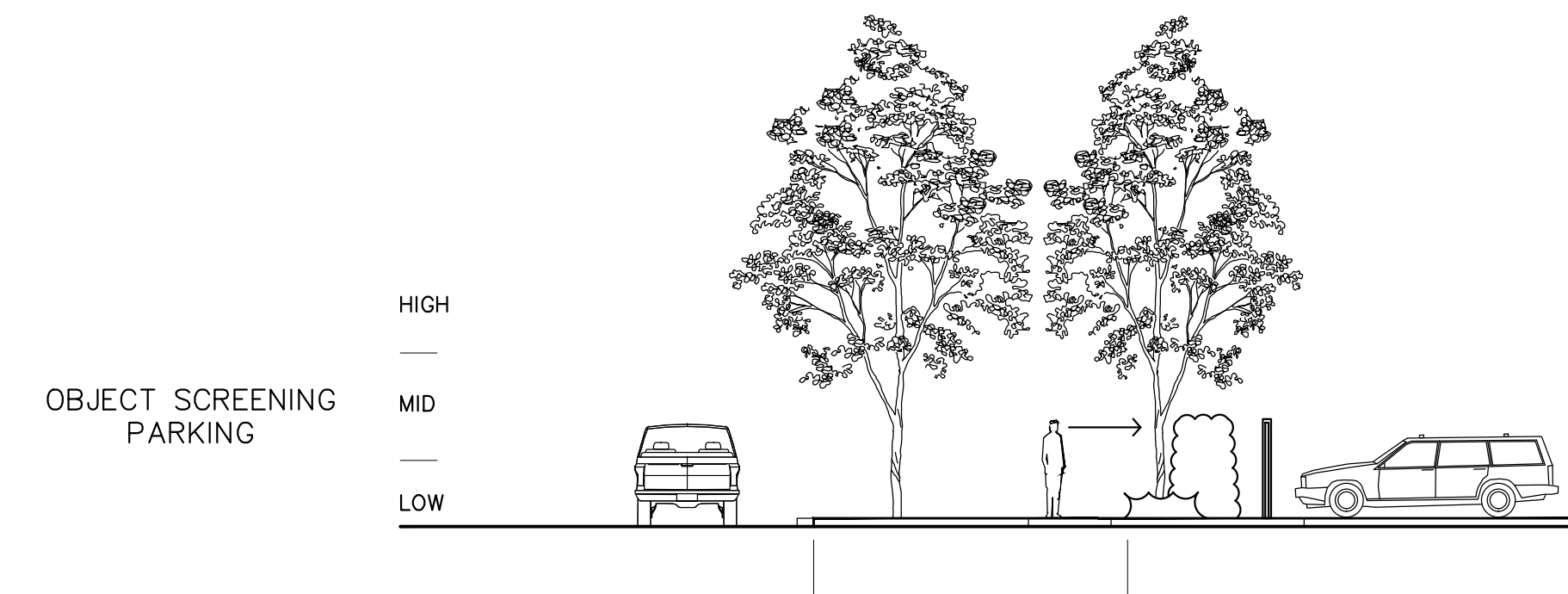

* Per City of Milwaukee Zoning Ordinance 295-405 Landscaping

WESTLAWN GARDENS PHASE II

6331 W Silver Spring Dr
MILWAUKEE WI 53218

Owner
Housing Authority of the City of Milwaukee
414.286.3629

Architect
Torti Gallas and Partners, Inc.
1300 Spring Street, 4th Floor
Silver Spring, MD 20910
301.588.4800
www.tortigallas.com

Local Architect
Quorum Architects
414.265.9265

Local Architect
Eppstein Uhen Architects
414.271.5350

Structural Engineer:
R.A. Smith National
262.317.3279

MEP Engineers:
Thunderbird Engineering, Inc.
414.352.2211

IBC Engineering Services, Inc.
262.549.1190

Civil Engineer:
R.A. Smith National
262.522.4416

Landscape Architect:
AVRES ASSOCIATES
608.255.0800

Issue

No.	Date

Revisions

No.	Date

Amenities/ Site Furnishings

Date
Principal In Charge
D.W.
Project Planner
Project Landscape Architect
B.M.
Project Manager
B.M.
Drawn
B.M., R.S., S.K.
Job No.
27-1052
Scale
1" = 2'-0"

Drawing No.
L601

TORTI GALLAS AND PARTNERS, INC. WESTLAWN gardens, phase II

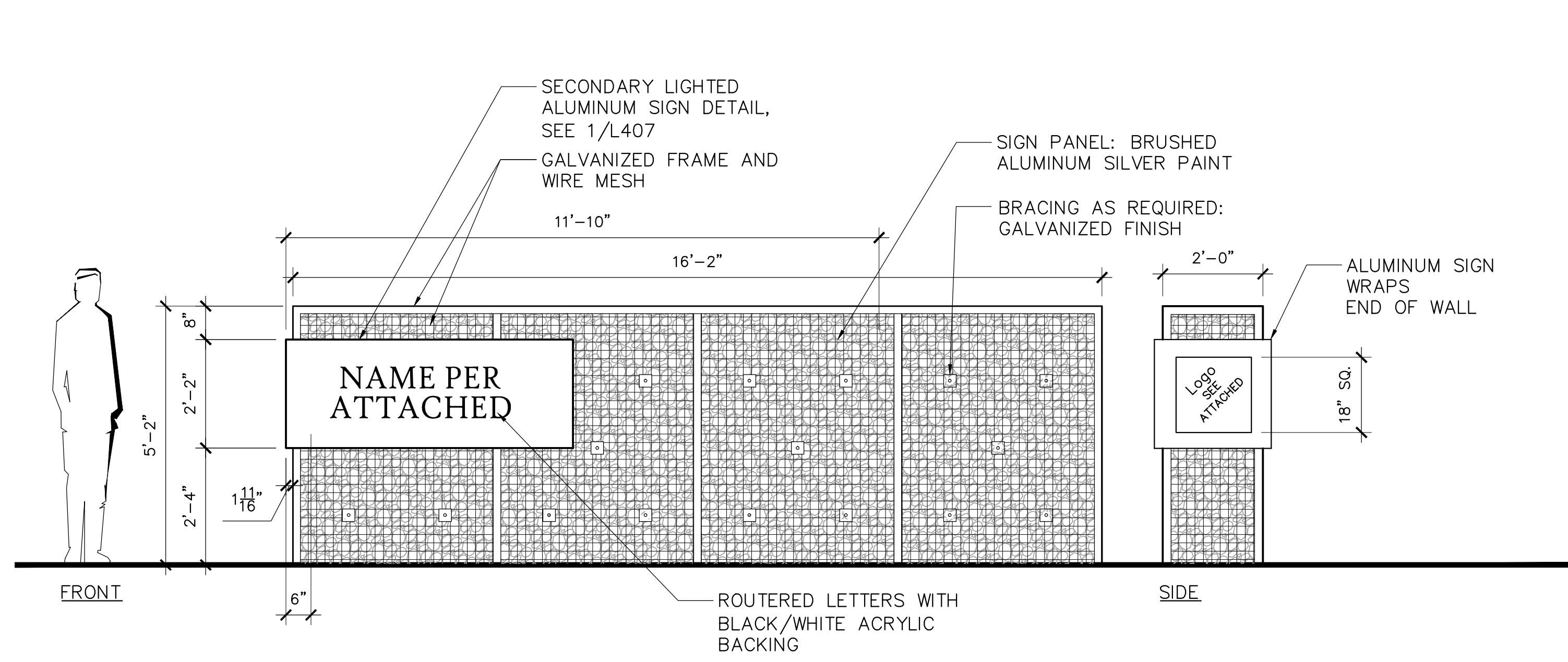

1 SECONDARY NEIGHBORHOOD ENTRANCE SIGN
L301

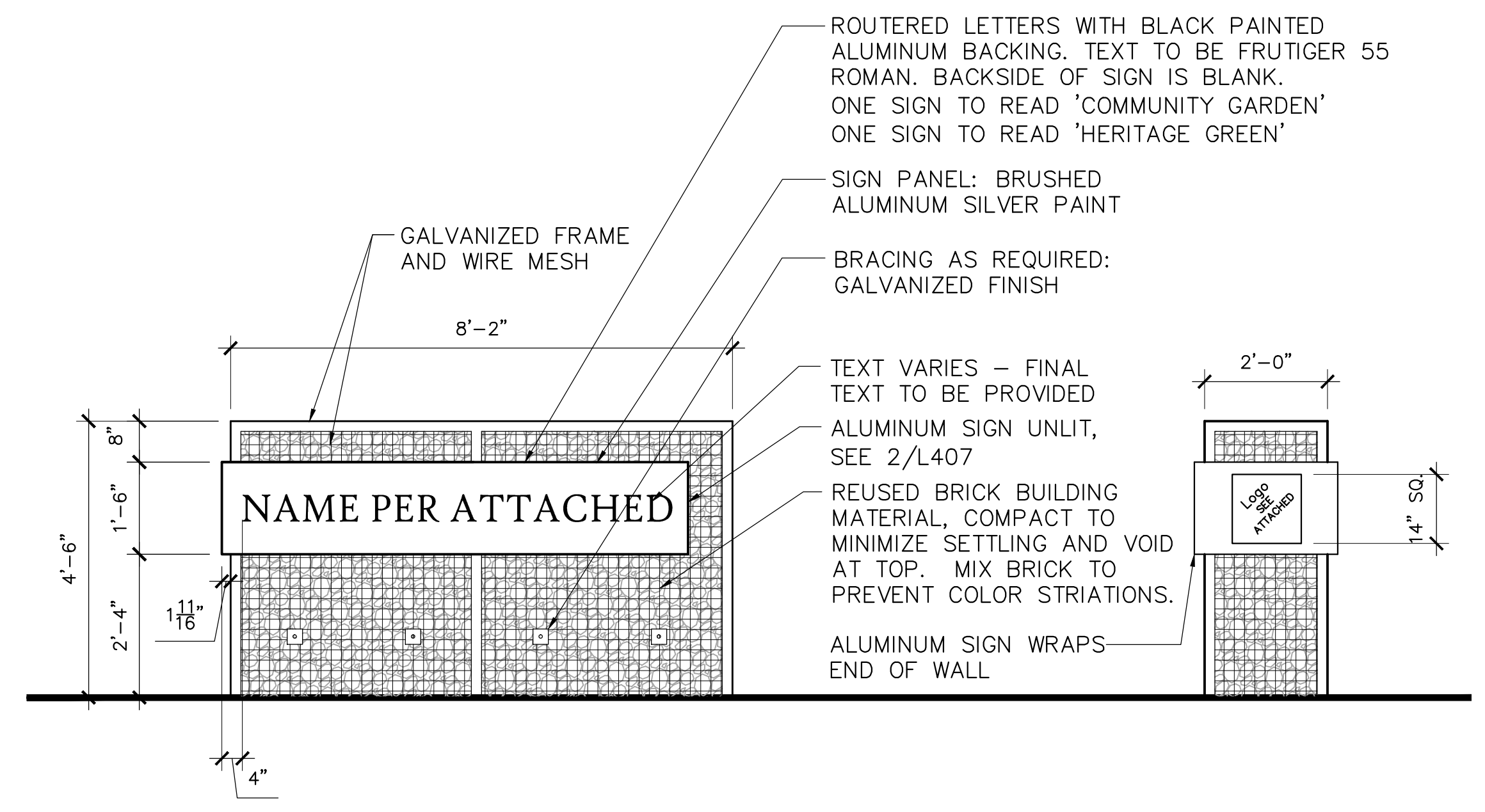

2 MULTI-PURPOSE SIGN
L301

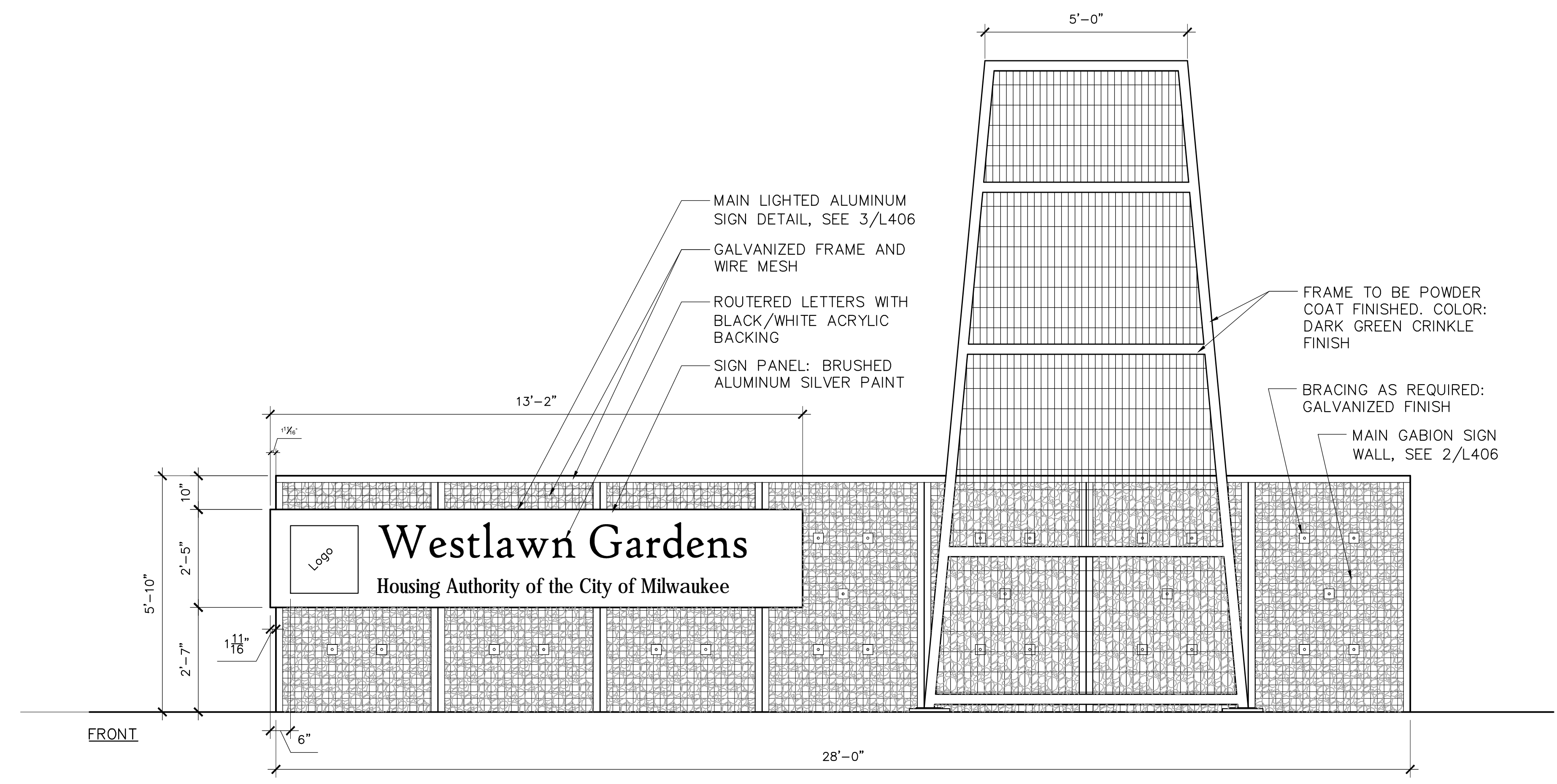

3 PRIMARY NEIGHBORHOOD ENTRANCE SIGN
L301

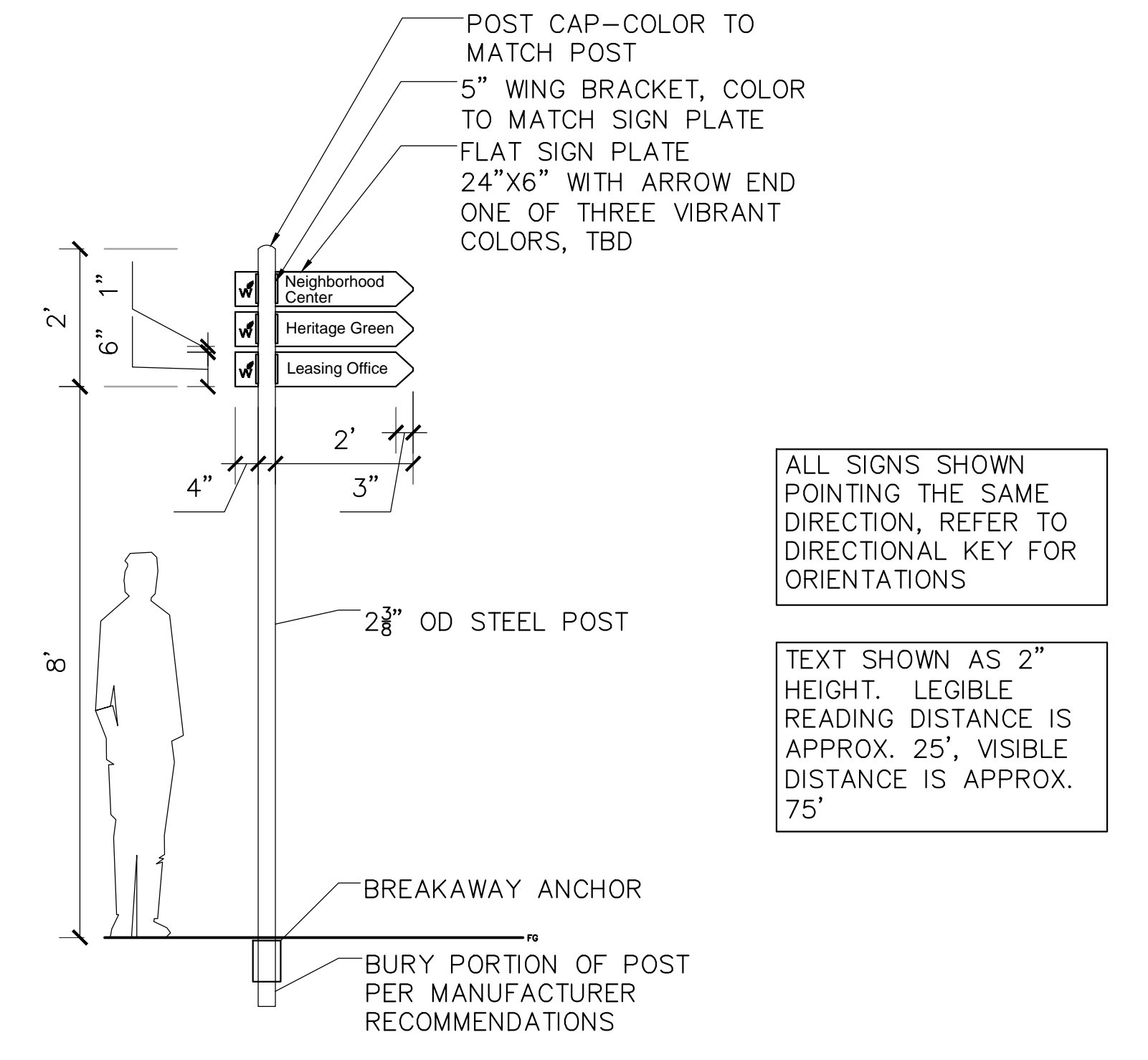

4 WAYFINDING SIGN
L301

ALL SIGNS SHOWN POINTING THE SAME DIRECTION, REFER TO DIRECTIONAL KEY FOR ORIENTATIONS

TEXT SHOWN AS 2" HEIGHT. LEGIBLE READING DISTANCE IS APPROX. 25', VISIBLE DISTANCE IS APPROX. 75'

File: P:\27-1052-WestlawnPhase2\CD\050-Signage.dwg Layout: L601 User: shawn Plotmed: Sep 30, 2016 - 11:52am

Amenities



BENCH SEATING

Proposed pattern for seat and back (where applicable)

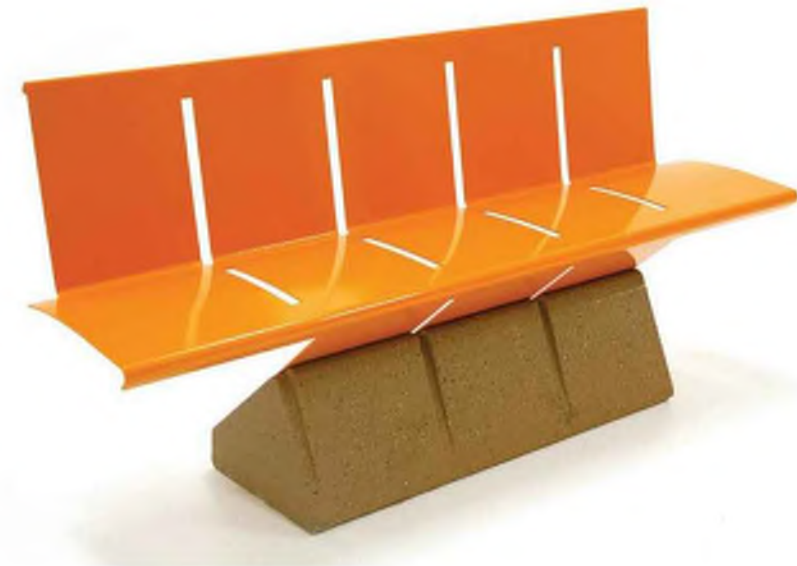
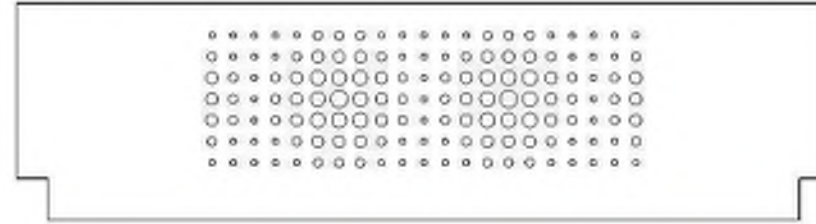

TRASH RECEPTACLE



TABLE SEATING

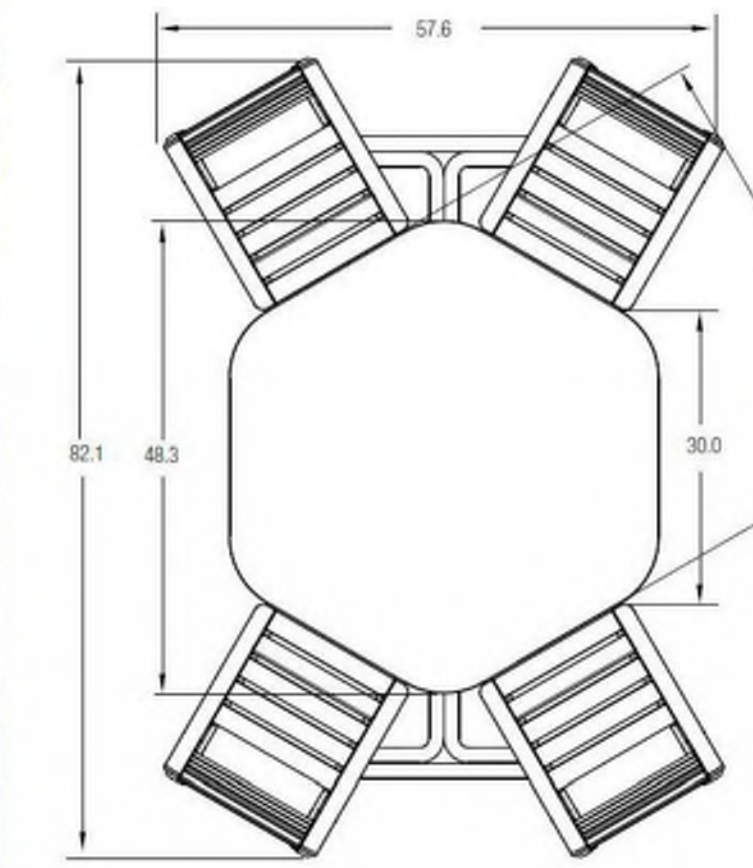

GABION SEATING



BIKE RACK

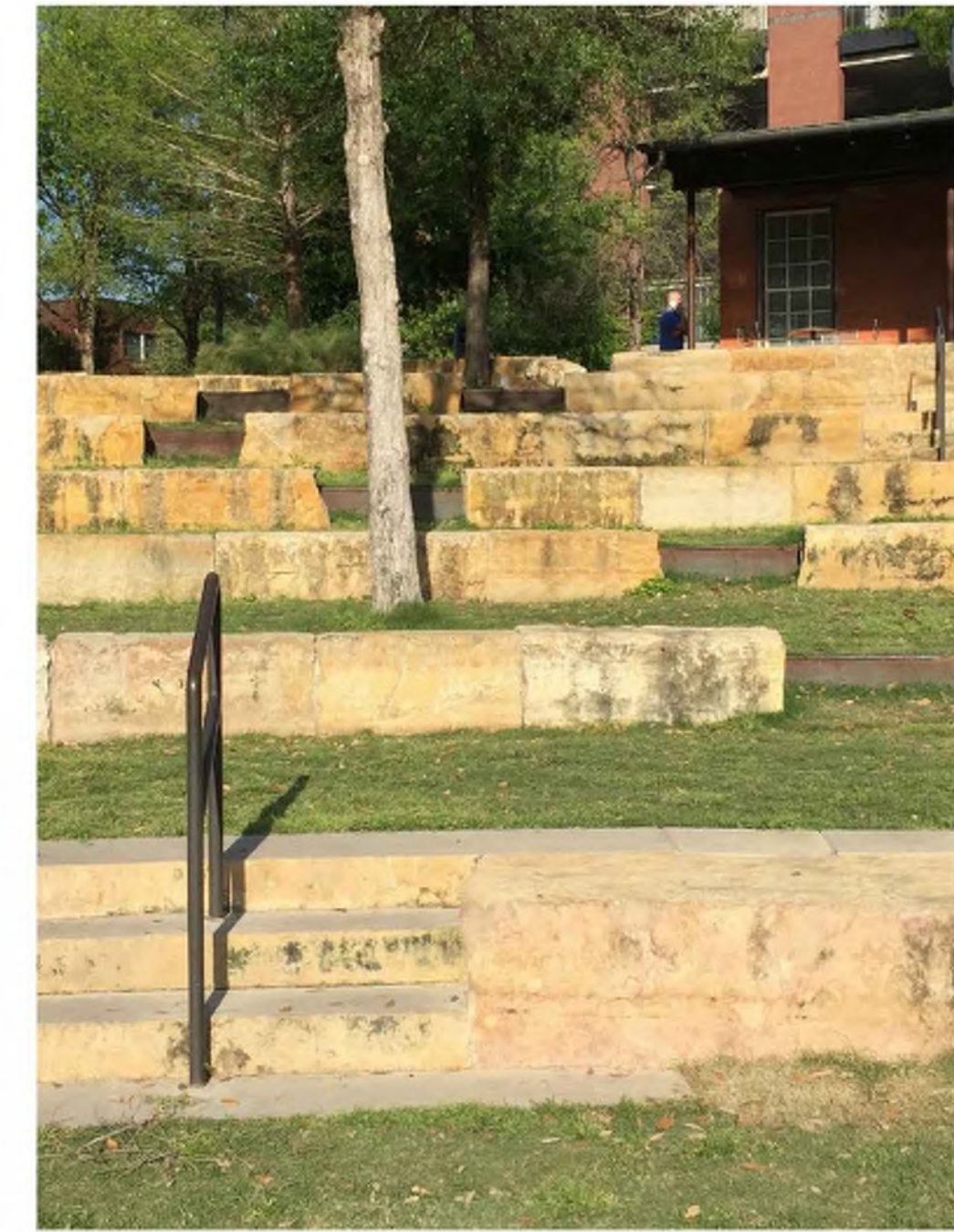

AMPHITHEATER SEATING / BLOCK STONE WALL



STREETSCAPE CHARACTER



STONE WALLS



RESIDENTIAL FENCE



SCREENING

WESTLAWN GARDENS PHASE II

6331 W Silver Spring Dr
MILWAUKEE WI 53218

Owner
Housing Authority of the City of Milwaukee
414.286.3629

Architect
Torti Gallas and Partners, Inc.
1300 Spring Street, 4th Floor
Silver Spring, MD 20910
301.588.4800
www.tortigallas.com

Local Architect
Quorum Architects
414.265.9265

Local Architect
Eppstein Uhen Architects
414.271.5350

Structural Engineer:
R.A. Smith National
262.317.3279

MEP Engineers:
Thunderbird Engineering, Inc.
414.352.2211

IBC Engineering Services, Inc.
262.549.1190

Civil Engineer:
R.A. Smith National
262.522.4416

Landscape Architect:
AVRES ASSOCIATES
608.255.0800

Issue

No. Date

Revisions

No. Date

Amenities/
Site
Furnishings

Date

Principal In Charge
D.W.

Project Planner

Project Landscape Architect
B.M.

Project Manager
B.M.

Drawn
B.M., R.S., S.K.

Job No.
27-1052

Scale
No Scale

Drawing No.

L602

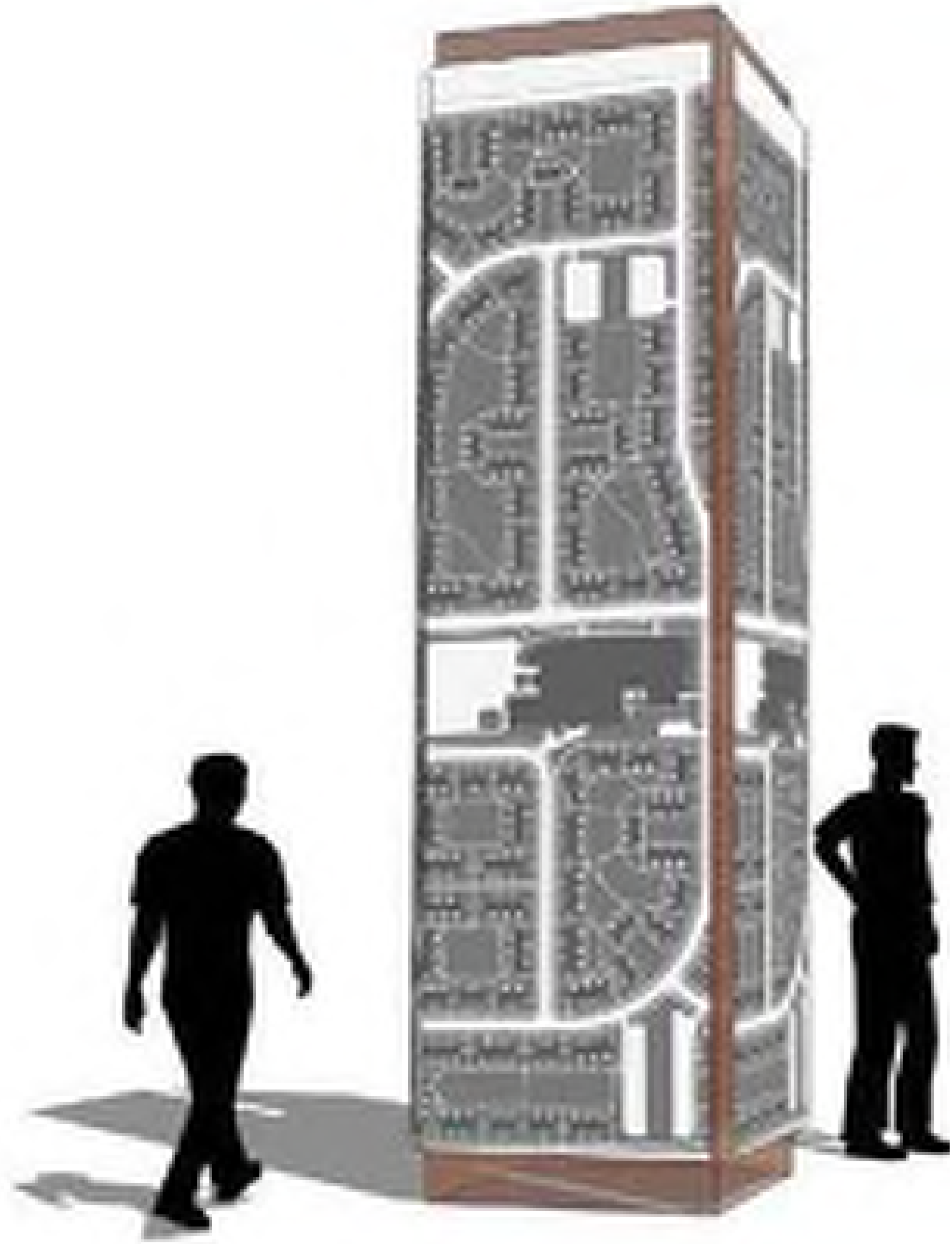

ICON TOWER - CHARACTER REPRESENTATION, MAY POTENTIALLY CHANGE



ROADWAY LIGHT



OPTIONAL PEDESTRIAN SCALE LIGHT FOR MEWS, PLAZAS, AND PARKS



PARK SHELTER / WARMING HOUSE WITH OPTIONAL REMOVABLE PANELS SIMILAR TO LIBRARY BUS STOP ON 64TH ST.

WESTLAWN GARDENS PHASE II

6331 W Silver Spring Dr
MILWAUKEE WI 53218

Owner
 Housing Authority of the City of Milwaukee
 414.286.3629

Architect
 Torti Gallas and Partners, Inc.
 1300 Spring Street, 4th Floor
 Silver Spring, MD 20910
 301.588.4800
 www.tortigallas.com

Local Architect
 Quorum Architects
 414.265.9265

Local Architect
 Eppstein Uhen Architects
 414.271.5350

Structural Engineer:
 R.A. Smith National
 262.317.3279

MEP Engineers:
 Thunderbird Engineering, Inc.
 414.352.2211

IBC Engineering Services, Inc.
 262.549.1190

Civil Engineer:
 R.A. Smith National
 262.522.4416

Landscape Architect:
 AVRES ASSOCIATES
 608.255.0800

Issue

No. Date

Revisions

No. Date

Amenities/ Site Furnishings

Date
 Principal In Charge
 D.W.
 Project Planner
 Project Landscape Architect
 B.M.
 Project Manager
 B.M.
 Drawn
 B.M., R.S., S.K.
 Job No.
 27-1052
 Scale
 No Scale

Drawing No.
L603