

MAGNUM

RIVETED ORNAMENTAL STEEL FENCING



THE NEW STANDARD IN RIVETED ORNAMENTAL

Magnum® by Ameristar represents the pinnacle of quality and value in riveted ornamental fencing. Magnum® features Ameristar's "standard of the industry" quality, PermaCoat® coating process, and an extensive product offering to fit virtually any application where product performance, features and maintenance-free ownership are required. No other riveted system on the market today compares.

TIMELESS APPEAL

The traditional look of a riveted system has long been a standard in ornamental fencing for over 40 years. Magnum® follows this tradition while providing for unsurpassed value not found in other riveted systems.

BLENDING THE OLD WITH THE NEW

Magnum® is offered in today's most popular styles and heights while retaining the architectural appeal of "old world" wrought iron. From light commercial to heavy industrial to a solid picket option, Magnum® offers a complete solution for today's consumer.

UNMATCHED DURABILITY

Peace of mind comes from knowing that Magnum® is protected by Ameristar's legendary PermaCoat® coating process. This industry leading process has consistently outperformed all other coating processes for the last 15 years and provides years of maintenance free protection.



We take great pride in manufacturing "Made in the USA" products. Ameristar is located in Tulsa, Oklahoma and is American owned and operated.

Applications:

- Stadiums & Event Centers
- Schools & Universities
- Public Housing Authorities
- Hospitals
- Parks & Recreation
- Water Treatment & Storage
- State Facilities
- Manufacturing Plants

AMERISTARFENCE.COM

PH. 888-333-3422

MKTG@AMERISTARFENCE.COM

MAGNUM[®]

RIVETED ORNAMENTAL STEEL FENCING

DESIGN

Magnum[®] is constructed by securing pickets with high strength rivets to the robust 1-3/8" x 1-1/2" steel rail. The riveted connection has a minimum 1100 lbs. of holding power with a shear strength of 1500 lbs.

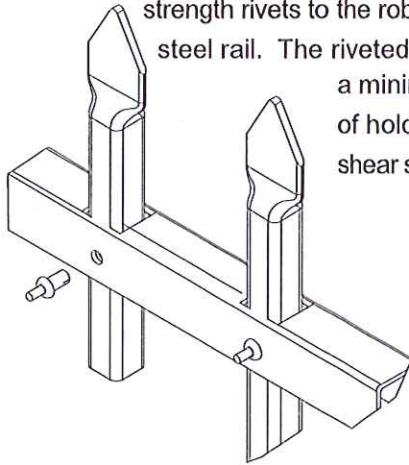

BRACKETS

For everyday installations Magnum is available in the ever popular flat mount bracket. Magnum is also available with the traditional encapsulated bracket.

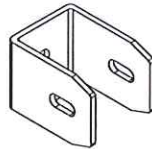

COATING & WARRANTY

Magnum is protected with Ameristar's unique PermaCoat[®] Multi-layer coating process. The combination of these layers deliver a system that increases weathering resistance and product durability.

Magnum[®] is manufactured using the highest quality materials and backed with Ameristar's 10 year warranty.

GATES

Magnum[®] has a wide variety of Swing, Slide, and Cantilever Gates to match any entry.

Magnum's engineered swing gates are available in leaf widths up to 24', allowing the owner to take advantage of a 48' gate opening.

OPTIONS

MAGNUM PLUS[®]

Pickets - 3/4" x 16 ga.

MAGNUM COMMERCIAL[®]

Pickets - 3/4" x 14 ga.

MAGNUM SOLID[®]

Pickets - 3/4" x Solid bar

MAGNUM INDUSTRIAL[®]

Pickets - 1" x 16 ga.

MAGNUM II[®]

Pickets - 1" x 14 ga.

Magnum Posts

Up to 6' height 2-1/2" Sq. x 14 ga.

6' to 8' height 2-1/2" Sq. x 12 ga.

Also available in 3" Sq. x 12 ga.

STYLES

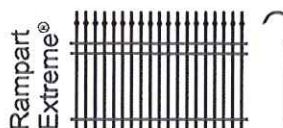
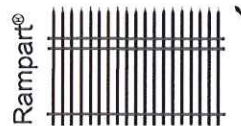

Effective: 12/2010 - Part # 98

AMERISTAR FENCE PRODUCTS
1555 N. MINGO RD.
TULSA, OK 74116

AMERISTARFENCE.COM

PH. 888-333-342
MKTG@AMERISTARFENCE.COM