



CERTIFICATE OF APPROPRIATENESS APPLICATION FORM

Incomplete applications will not be processed for Commission review.
Please print legibly.

1. **HISTORIC NAME OF PROPERTY OR HISTORIC DISTRICT:** (if known)

ADDRESS OF PROPERTY:

2. **NAME AND ADDRESS OF OWNER:**

Name(s):

Address:

City:

State:

ZIP:

Email:

Telephone number (area code & number) Daytime:

Evening:

3. **APPLICANT, AGENT OR CONTRACTOR:** (if different from owner)

Name(s):

Address:

City:

State:

ZIP Code:

Email:

Telephone number (area code & number) Daytime:

Evening:

4. **ATTACHMENTS:** (Because projects can vary in size and scope, please call the HPC Office at 414-286-5712 for submittal requirements)

A. REQUIRED FOR MAJOR PROJECTS:

Photographs of affected areas & all sides of the building (annotated photos recommended)

Sketches and Elevation Drawings (1 full size and 1 reduced to 11" x 17" or 8 1/2" x 11")
A digital copy of the photos and drawings is also requested.

Material and Design Specifications (see next page)

B. NEW CONSTRUCTION ALSO REQUIRES:

Floor Plans (1 full size and 1 reduced to a maximum of 11" x 17")

Site Plan showing location of project and adjoining structures and fences

PLEASE NOTE: YOUR APPLICATION CANNOT BE PROCESSED UNLESS BOTH PAGES OF THIS FORM ARE PROPERLY COMPLETED AND SIGNED.

5. DESCRIPTION OF PROJECT:

Tell us what you want to do. Describe all proposed work including materials, design, and dimensions. Additional pages may be attached via email.

6. SIGNATURE OF APPLICANT:

Signature *John F. Kelley* _____

Please print or type name

Date

This form and all supporting documentation MUST arrive by 4:00 pm (11:59 pm via email) on the deadline date established to be considered at the next Historic Preservation Commission Meeting. Any information not provided to staff in advance of the meeting will not be considered by the Commission during their deliberation. Please call if you have any questions and staff will assist you.

Mail or Email Form to:

Historic Preservation Commission
City Clerk's Office
841 N. Broadway, Rm. B1
Milwaukee, WI 53202

PHONE: (414) 286-5712 or 286-5722

hpc@milwaukee.gov

www.milwaukee.gov/hpc

Or click the SUBMIT button to automatically email this form for submission.

St. Benedict the Moor Catholic Church

Milwaukee, Wisconsin



Basement Level Window Replacement Project

Submission for Certificate of Appropriateness

City of Milwaukee Historic Preservation Commission

September 12, 2022

Submitted by:

MKB Architects

1918 North Mendell Street, Suite 300

Chicago, Illinois 60642

Project Description:

St. Benedict the Moor is a Roman Catholic Church that was designed by Erhard Brielmeier and Sons and built in 1923 on a prominent site in the Civic Center portion of the Central Business District. The major formal entrance façade of the building faces south, with more utilitarian facades facing a parking lot to the east and a fenced courtyard to the west. The main floor of the building, accessed by a monumental stair, houses the Church Sanctuary and supporting spaces, while the lower level holds a multi-purpose space used by both the Parish and an outreach service called St. Ben's Community Meal, which serves free meals to the community's needy several nights a week.

A recent project was undertaken to add air conditioning to the Lower Level spaces (those that serve the Community Meal space) to address issues of comfort and ventilation. To further address these concerns, it is proposed that the old, original wood double-hung windows located in this space be replaced. The windows show signs of significant deterioration, and their proposed replacement is intended to achieve improved appearance, lower energy use and increased security. The purpose of this submission is to seek a Certificate of Appropriateness from the Historic Preservation Commission in support of this project.

(Note: Additional supporting drawings and documentation are attached to this summary as Appendices. See references in the following text.)

Existing Conditions:

As noted above, this project focuses ONLY on the Lower Level windows located on the east and west facades. In general, both facades feature existing wood double-hung basement windows, which are different heights and configurations on each side of the building. On the east side, the windows are taller, and each sash is divided into 4 equal lights by muntin bars. On the west side, the windows are shorter in height due to a higher finished grade at the face of the building. These windows are also double-hung, but each sash is divided into only two equal lights by muntin bars.

Windows on both sides of the building are protected by security grates or bars that have been bolted to the window frames or to the brick masonry surrounding each opening. These served both to provide security against break-in and, on the east side, to protect against glass breakage when the parking lot served as a playground area. These screens are intended to be permanently removed as a part of this project.

St. Benedict the Moor

Window Replacement Project

Page Three

Existing Conditions: (Continued)

The windows currently are glazed with several types and colors of patterned glass, some of which is cracked or broken. The sash themselves either do not fit tightly in their frames or bind when operated. Physical damage has occurred due to the use of hooked rods to reach and operate the high windows from the floor. No window screens are present on any of the existing windows. And, preliminary investigation has led to the conclusion that many of the multiple layers of paint on both sides of each window contain lead, requiring abatement if the proposed project is to move forward.

Project Rationale

The concept of replacing the windows at the basement level was first raised in an energy audit report prepared by Rivion in 2020, a portion of which is provided in the Appendix. They note (on page 8, Issue #2) that the basement windows do not close properly or completely, leading to energy losses, and they recommend corrective action. Obviously controlling costs is an important consideration for a not-for-profit organization, and energy savings is a goal shared by everyone. New insulated window units with low-E glass, properly installed with all flashings and sealants, will be the best way of addressing energy concerns.

The building uses steam heat from the local power generation plant, and the Lower Level has been provided with new air conditioning equipment to cool the space in the summer months. However, the general intent is to use the operable windows to provide healthy, natural cross-ventilation through the Community Meal space. Having new windows that will operate easily and smoothly will better support this function. And, with the addition of window screens, flies and other insects will be prohibited from entering the cooking and dining areas of the Lower Level.

Replacing the existing windows will improve the building by restoring the crisp lines and appearance of the original windows in this building that will celebrate its centenary next year. Removal of the security grates and patterned glass will lead to a less institutional look to the building, something that is particularly inhospitable to the populations served by the Community Meal mission. Security will be provided by upgraded electronic security devices located within the Meal Hall space.

And finally, removing and replacing the window units and their lead-based paint will provide a safer and healthier environment for both adults and the many children who visit the building.

Proposed Solution

While the formal south façade of the Church is of primary concern, The Historic Preservation Study Report (prepared in Fall of 1997) identifies the east and west facades of the building of secondary importance, allowing for a little flexibility in the application of HPC's recommendations. Nonetheless, the following items are noted for Windows and doors on this building:

St. Benedict the Moor

Window Replacement Project

Page Four

Proposed Solution (Continued)

1. Retain existing openings.
2. Retain existing configuration of panes, sash, surround and sills.
3. Avoid making additional openings or other changes in fenestration.
4. Respect the building's stylistic period; If replacement of elements is necessary, the replacement should duplicate the appearance and design of the original element.

The National Park Service provides further guidelines related to the proposed scope of work. In evaluating the windows, their primary determinant of need for this work is extreme deterioration, and their basic recommendation is to repair rather than replace damaged windows. However, they note that the importance of the windows to the historic character of the building can be taken into account, and that the presence of hazardous materials and energy performance may also be taken into account in establishing a need for window replacement.

In addition to evaluating need, the Park Service documents also provide very detailed requirements for the replacement of existing windows on an historic building. However these can be summarized by simply stating that replacement windows are to match the originals in every way including size, function, configuration of window elements, relation to adjacent wall surfaces, window materials and glass type and appearance. Once again, there is some flexibility in the application of these standards to windows of secondary importance to the historic character of the building.

The proposed window replacement system for the basement windows in this facility are Marvin Ultimate Series G-2 Single-Hung windows. The proposed windows are aluminum clad wood windows fabricated to fit the existing masonry openings without modification. The proposed windows are intended to match the appearance of the existing wood windows that they would be replacing, and they would feature a similar type of operation and frame and sash sight lines. (Note that the single hung units match the manufacturer's double hung units in appearance, but only one sash is mobile. This change is intended to address security concerns. This will result in a better-looking alternative to replacing the security grates at all openings.) The windows would also feature insulated glass with narrow muntin bars matching the existing ones in configuration (with inner and outer components and an interior spacer bar to further mimic true divided lights). Low-E vision glass is being proposed to allow for visual connection to the outside in lieu of the current mis-matched patterned glass. And as noted above, the security grates and burglar bars currently covering the window openings from the outside would be removed, further improving the appearance of the building. Window exterior color is to be selected from Manufacturer standards to match existing as closely as possible.

Note that several of the existing window openings have been modified from the original over time by the installation of exhaust ductwork or piping serving mechanical equipment. These openings are to receive replacement windows matching the others, but in slightly modified configurations to reflect the conditions at those openings.

St. Benedict the Moor

Window Replacement Project

Page Five

Proposed Solution (Continued)

Product information for the proposed replacement windows is provided in the appendix to this document.

Conclusion

The St. Benedict Church facility is an important visual element in the civic center area in which it sits and it serves as a beacon of hope for the community it serves. To continue in its mission, the building must continue to be updated and improved to ensure that it continues to meet the needs of its users while maintaining its historic character. The proposed replacement of the basement level windows with new units is intended to meet these goals, and we respectfully request that a Certificate of Appropriateness be granted for the project as proposed.

St. Benedict the Moor Catholic Church

Milwaukee, Wisconsin



Basement Level Window Replacement Project

Appendix 1: Drawings & Photographs

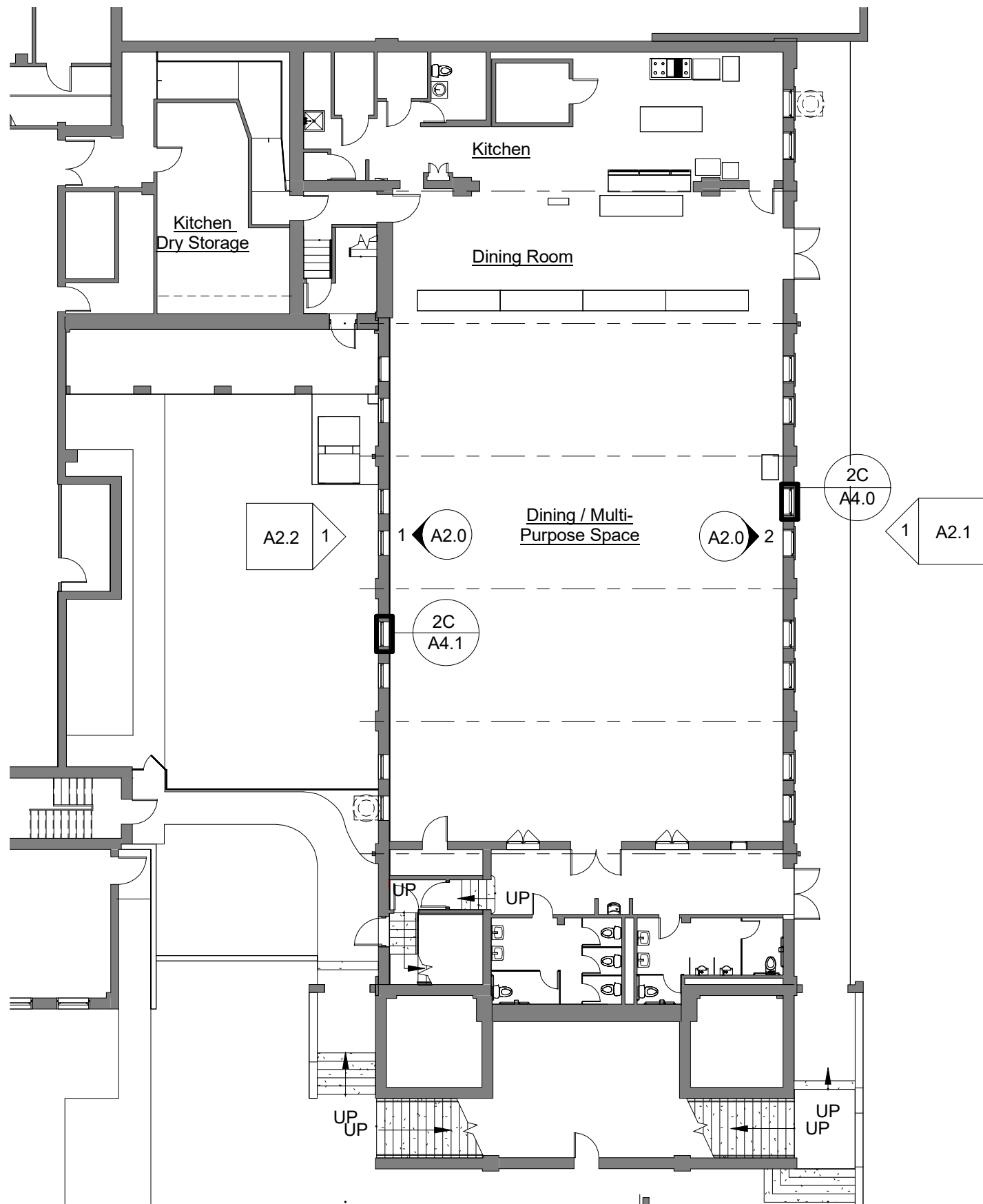

LOWER LEVEL PLAN

1/16" = 1'-0"



St. Benedict the Moor
 930 West State Street
 Milwaukee, Wisconsin

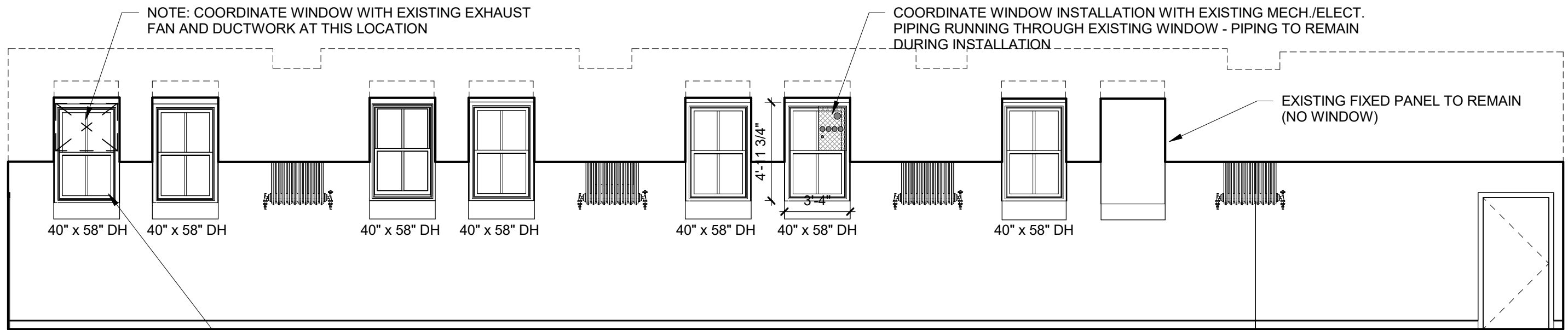

1 West Elevation

SCALE: 3/16" = 1'-0"
 0' 2' 4' 10'

NOTE: FIXED WINDOW UNIT AT THIS LOCATION TO ACCOMMODATE EXISTING MECHANICAL DUCTWORK.

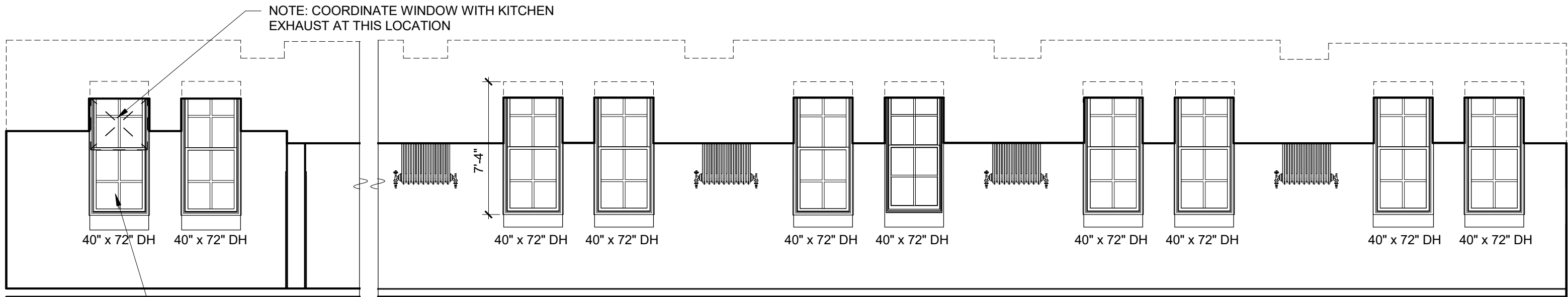

2 East Elevation

SCALE: 3/16" = 1'-0"
 0' 2' 4' 10'

Window Replacement Scope Notes:

Remove existing Basement Level windows as shown (Coordinate with lead paint abatement by others). Remove exterior security grates and repair masonry as required. Install new aluminum clad wood replacement windows as follows: Match frame width and exterior brick mold trim profiles as closely as is practical. Provide operable sash with true divided lights (match existing muntin bar thickness and profile as closely as possible). Provide clear vision insulating glass with low-e coating. Windows to meet current Energy Codes. Verify aluminum and wood finishes (to be chosen from manufacturer's standard range.) Coordinate installation with Owner's security vendor for installation of contacts, glass break sensors as required. Note: at West windows, provide alternate pricing to provide safety glass at exterior side of window. Verify all sizes and frame conditions in the field.



St. Benedict the Moor
 930 West State Street
 Milwaukee, Wisconsin

INTERIOR ELEVATIONS

3/16" = 1'-0"

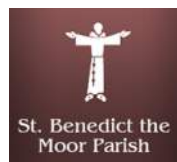

St. Benedict the Moor
930 West State Street
Milwaukee, Wisconsin

EXTERIOR ELEVATION - EAST

3/32" = 1'-0"

A2.1
09/06/22



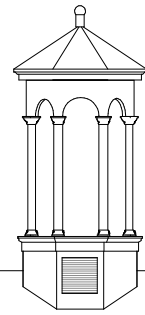

EXISTING PIPE AND CONDUIT CONNECTIONS TO REMAIN RUNNING THROUGH EXISTING WINDOW OPENING

LINE OF MECH. CONDENSING UNITS (SHOWN DASHED)

EXISTING FIXED PANEL TO REMAIN (NO WINDOW)

EXISTING FRESH AIR INTAKE FAN AND DUCTWORK TO BE REINSTALLED AFTER NEW WINDOW IS INSTALLED

2A
A4.1

SCOPE OF WINDOW REPLACEMENT WITHIN BOX ONLY

FIXED FRAME WINDOW UNIT TO ACCOMMODATE EXISTING DUCTWORK.



St. Benedict the Moor
930 West State Street
Milwaukee, Wisconsin

EXTERIOR ELEVATION - WEST

3/32" = 1'-0"

A2.2
09/06/22





EAST ELEVATION OVERALL

SCOPE OF WINDOW
REPLACEMENT
WITHIN BOX ONLY

EXISTING SECURITY
GRATES TO BE
REMOVED (TYP.)



TYPICAL EAST WINDOW & DETAILS



SCOPE OF WINDOW
REPLACEMENT
WITHIN BOX ONLY



EXISTING SECURITY
GRATES AND BARS TO
BE REMOVED (TYP.)



WEST ELEVATION OVERALL

TYPICAL WEST WINDOW





TYPICAL EXISTING WEST WINDOWS - INTERIOR



TYPICAL EXISTING EAST WINDOW - INTERIOR



EXISTING WINDOWS - DETAILS

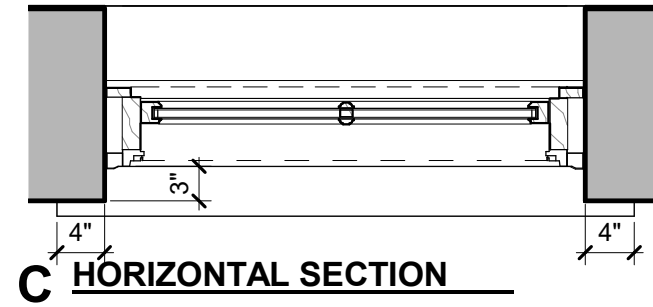
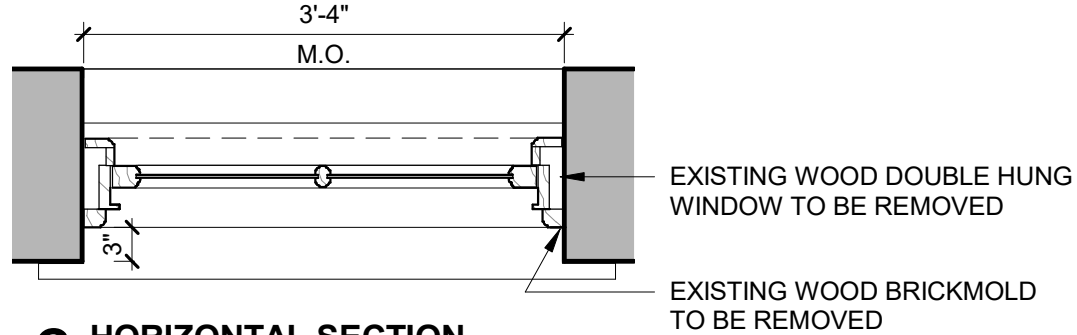

C HORIZONTAL SECTION

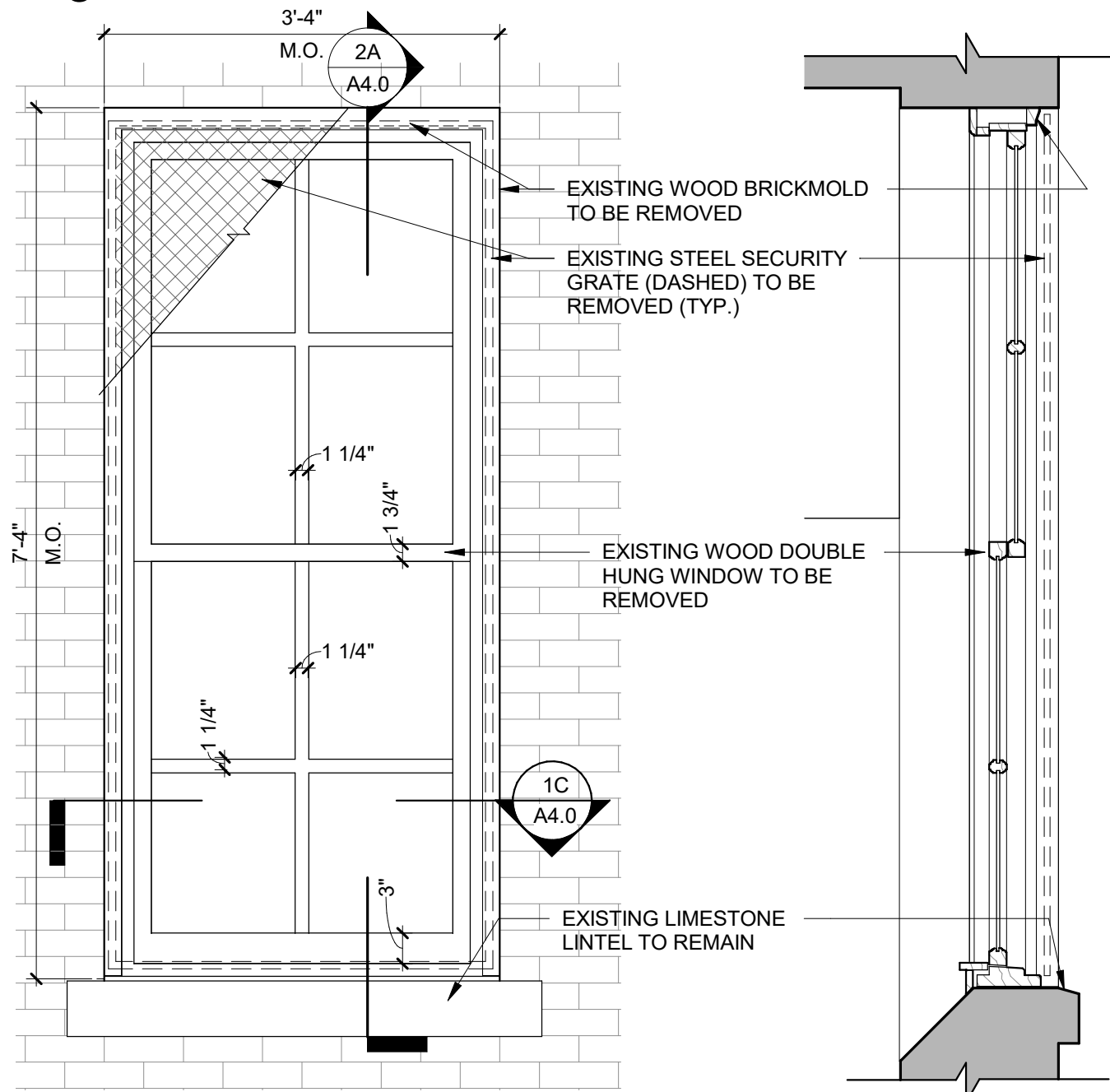

A ELEVATION

B SECTION

1 EXISTING EAST WINDOWS

SCALE: 3/4" = 1'-0"

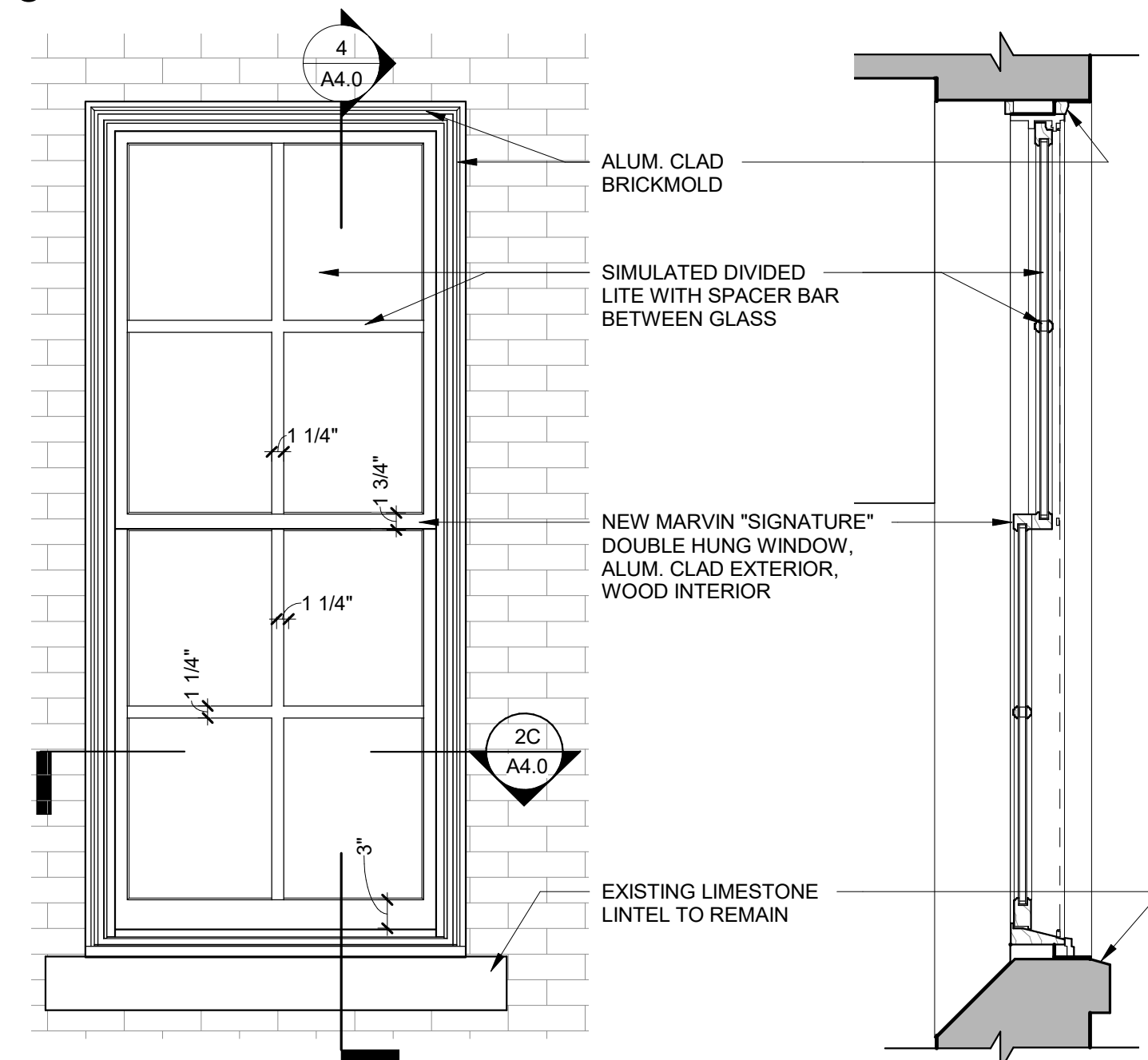
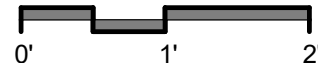

A ELEVATION

B SECTION

2 PROPOSED EAST WINDOWS

SCALE: 3/4" = 1'-0"



EXISTING / PROPOSED EAST WINDOWS

3/4" = 1'-0"



St. Benedict the Moor
930 West State Street
Milwaukee, Wisconsin

A4.0
09/06/22



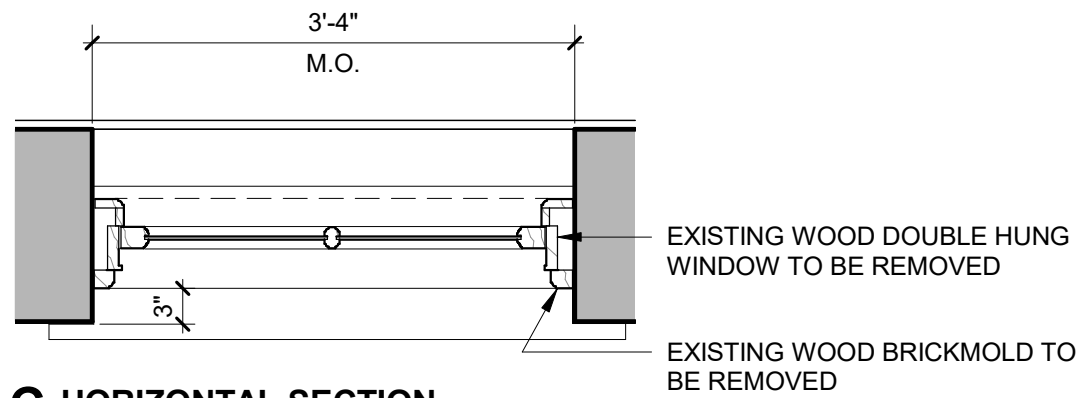

C HORIZONTAL SECTION

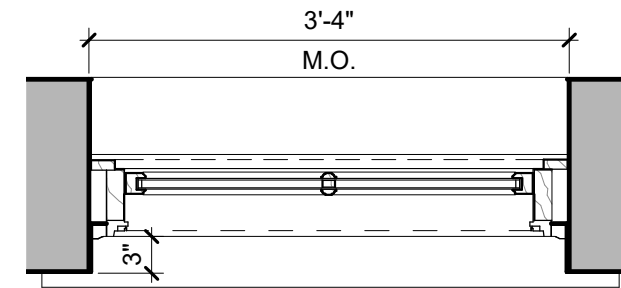

C HORIZONTAL SECTION

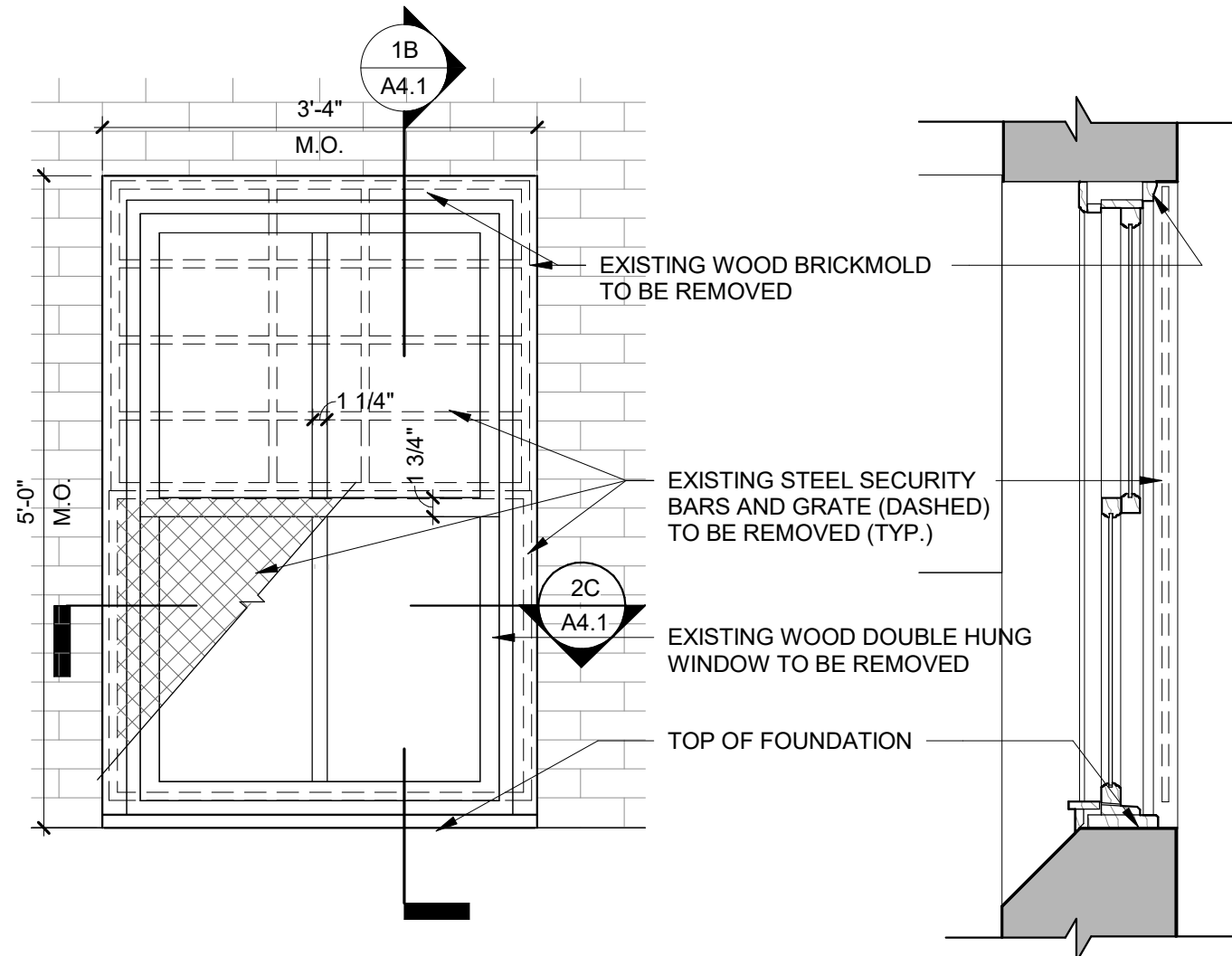

A ELEVATION

B SECTION

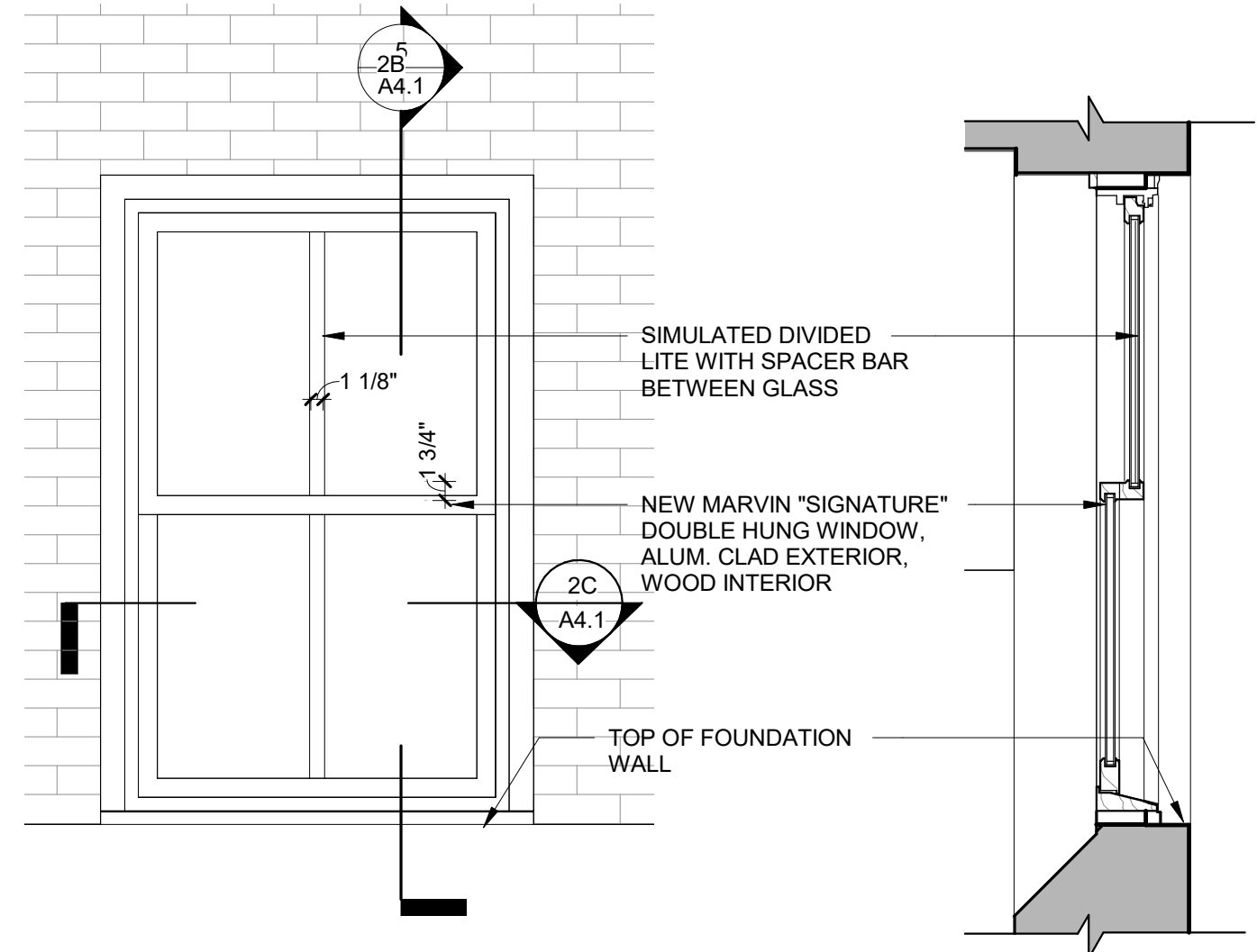

A ELEVATION

B SECTION

1 EXISTING WEST WINDOWS

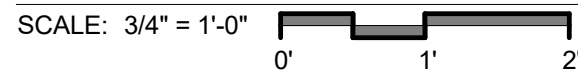

2 PROPOSED WEST WINDOWS

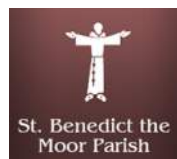
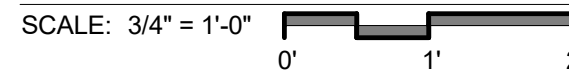

St. Benedict the Moor
930 West State Street
Milwaukee, Wisconsin

EXISTING / PROPOSED WEST WINDOWS

3/4" = 1'-0"

A4.1
09/06/22



St. Benedict the Moor Catholic Church

Milwaukee, Wisconsin



Basement Level Window Replacement Project

Appendix 2: Historic Preservation Study Report

HISTORIC PRESERVATION STUDY REPORT

ST. BENEDICT THE MOOR ROMAN CATHOLIC CHURCH

(Written Fall 1997)

I. NAME

Historic: St. Benedict the Moor Roman Catholic Church

Common: St. Ben's Roman Catholic Church

II. LOCATION

924 West State Street

Tax Key: 391-0258-211

Legal Description: COMPRISING ONLY THE LAND THE CHURCH STRUCTURE OCCUPIES. SURVEY AND SUBD INTO CITY LOTS OF THE N 30 ACRES ETC IN THE NW ¼ SEC 29-7-22. BLOCK 198 PART BEG AT SE COR SD BLK 198 TH NWLY ALG N LI W STATE ST 228.25' -TH N 95.85' -TH W 14.16' -TH N 32.3' M/L-TH E 4.8' M/L-TH N 10.6' M/L-TH E 89.48' - TH S TO THE N LI W STATE ST.

III. CLASSIFICATION

Structure

IV. OWNER

Capuchin Fathers
1740 Mount Elliot Avenue
Detroit, MI 48207

Local contacts: Rev. Michael Sullivan
Pastor
St. Benedict the Moor Church
1015 N. 9th St.
Milwaukee, WI 53233

V. YEAR BUILT

1923

Architect: Erhard Brielmeier and Sons

VI. PHYSICAL DESCRIPTION

The St. Benedict the Moor Roman Catholic Church is sited on a berm almost a full story above the sidewalk in the Civic Center portion of Milwaukee's Central Business District across the street from the county courthouse and the municipal justice center complex. The building is set back from the sidewalk behind an architecturally articulated monumental staircase. To the east of the church is a parking lot; while to the west is the six-story former St. Anthony's Hospital building. Neither of these properties is included in this nomination.

The church is a rectangular, two-story, brown brick, gable-roofed structure of Lombard Romanesque design. The north, east and west elevations are fairly utilitarian in character, while the south elevation is handsomely and formally articulated as the building's façade.

The façade is composed of a broad, slightly projecting central bay containing the two arched entrance portals in its first story, surmounted by a large circular window. Above the circular, stained glass, second story window, the attic story rises above the roof to form a richly corbelled gabled parapet.

The narrow single bays flanking the projecting central bay are fenestrated with small arched one-over-one windows. Brick corbelling embellishes the raking gables, which project slightly above the tile roof to form low parapet walls.

The east and west elevations are nearly identical. The east elevation consists of seven bays defined by projecting piers. The central five bays each have a pair of tall basement level windows surmounted by pairs of story-and-a-half tall arched auditorium windows. The north and south end bays each have three tiers of windows defining the basement, first and second story levels. A corbel table frieze trims the eaves. The west elevation is similar.

The only other ornamental feature is the copper clad open belfry located at the peak of the tile roof toward the rear of the building.

VII. SIGNIFICANCE

St. Benedict the Moor Roman Catholic Church is historically significant as the last surviving historic church building in Milwaukee originally built to house an African-American congregation and the first and only Roman Catholic congregation in Wisconsin established virtually the last physical reminder that Milwaukee's African-American community originally inhabited the western portion of the central business district and that this area remained its heart until well into the twentieth century. St. Benedict's is architecturally significant as a fine example of early twentieth century Lombard Romanesque style ecclesiastical architecture by one of the Midwest's most prolific and prominent church architects, Erhard Brielmeier and Sons.

VIII. HISTORY

Roman Catholic missionary work among Milwaukee's African-American community began in 1886 through the efforts of Charles Boettinger. About 140 persons worshipped at St. Gall's Church on West Michigan Street and later at Holy Name Church in the 1000 block of West State Street. The initial group diminished over time and it was not until 1908 that efforts were again made to bring African-Americans into the Catholic Church. These efforts were spearheaded by a layman, C. Lincoln Valle of Chicago, who moved to Milwaukee on August 25, 1908 with the specific intention of leading Milwaukee's Black residents to the Roman Catholic Church. As part of his efforts, Valle also began publishing *The Catholic Truth*, patterned after a paper of the same name in Chicago. At this time the Roman Catholic Church

had a policy against proselytizing for members, but would provide sacramental services and instruction for those interested in joining the church. In response to Valle's requests, Old St. Mary's Church made its school hall available for meetings of Valle's group. Later St. Mary's clergy attended to the spiritual needs of the mission when the 50 to 60 member group rented a store in the 900 block of North 4th Street to use as a gathering place.

On May 27, 1909 the group leased a building at 536 West State Street, across from the Auditorium building, and in June of that year the chapel was dedicated to St. Benedict the Moor, a Black Franciscan Father who lived in Sicily 450 years ago. The Capuchin brothers, headquartered at their monastery at North 4th and West Brown Streets, began attending to the spiritual needs of the group when St. Mary's clergy were unavailable and formally accepted full responsibility for the Mission on January 16, 1911. By this action St. Benedict's came to be staffed and financially supported by the capuchin order rather than the Archdiocese of Milwaukee, although it was understood that the mission could revert to the Archdiocese upon the latter's request.

The Capuchins under the temporary pastor, Fr. Paul Reichertz, began work to find St. Benedict's a permanent home, and after much racial prejudice and obstructionist tactics, the building at 1041 North 9th Street was purchased on November 7, 1911 and remodeled as a chapel. Fr. Cyril Kufner was appointed pastor in 1912, and another building was purchased on the same block to serve as a school, which opened on September 4, 1912 with nine pupils under the care of the School Sisters of Notre Dame. Fr. Stephen Eckert became the mission's first resident pastor in 1913 and was known for his exceptional devotion to his congregation and the African-American community in general as well as for this deep spirituality. To counteract the adverse effects of being raised in poor, single-parent households and growing lack of supervision of children in the city's African-American community, Eckert started a boarding school at St. Benedict's, the first co-educational parochial boarding school in the Midwest. Attendance grew to 73 children in 1914, of which 36 were boarding students, some coming from out-of-state. Funds to operate the chapel and school and to board the students came from various raffles, special social events and concerts, and the direct soliciting of funds from other parishes and even well to do Milwaukeeans.

The need for better accommodations for the students led the Capuchins to temporarily relocate the boarding school to today's Sturtevant, Wisconsin in 1920 when the Dominican Sisters of Racine offered the use of their vacated complex to St. Benedict's. Although enrollment grew to 120 students, St. Benedict's had to return to Milwaukee in the fall of 1921 when the nuns decided to sell the property. The Dominicans from Racine eventually took over the teaching duties at Milwaukee.

Fr. Stephen Eckert died in 1923, as the Mission was entering a period of remarkable expansion. After being given permission to build a new chapel and hospice. St. Benedict's purchased land on North 10th Street and secured the services of the architectural firm of E. Brielmaier & Sons to design the new chapel, although funds for its construction had not yet been secured. Opposition from the City Land Commission and Archbishop Messmer stalled the project at first, but the Capuchins convinced the city that their chapel would not hinder the Civic Center and County Courthouse project then underway across West State Street. The Archbishop's concerns about having to take over a costly building project should the Capuchins run into financial difficulties were allayed when the Capuchin Order formalized their administration of the Mission through a canonical transfer, approved by the Pope, in 1923. By this action, St. Benedict's was removed from Archdiocesan authority, which relieved the Archdiocese of any potential financial burdens.

That same summer, Ernest G. Miller, president of Miller Brewing Company, fortuitously stopped at St. Benedict's rectory after noticing that construction had begun on a building near his brewery. When he found out that the money had not yet been raised for the new chapel, he pledged his financial support to build it, a pledge that would ultimately total over \$63,000. The new Chapel, of Lombard Romanesque design, was built facing West State Street and was dedicated on March 2, 1924. Later that year Miller contributed \$100,000 toward the purchase of the vacated Marquette University High School and grounds located a block away at the northwest corner of North 10th and West State Streets. St. Benedict's constructed an addition to the old Marquette building and used it for classrooms, a student dining area, and as living quarters for the Dominican nuns. The school opened in its new building in September of 1925 with 185 students. Mr. Miller died shortly afterwards, bequeathing \$200,000 to the congregation. By the early 1930s the school was averaging 220 to 260 students per year. Around 1937 a high school was opened as well, and the boarding was dropped. Enrollment at the high school declined in the early 1950s, but had stabilized at something over 70 students by the late 1950s.

The Capuchins also turned their attention to health care and built a 42-bed hospital costing \$98,190 on North 10th Street next to the church. It was designed by the architectural firm of E. Brielmaier & Sons and was dedicated on May 10, 1931 under the patronage of St. Anthony of Padua. The Franciscan Sisters of the Immaculate Conception were retained to staff the health care facility. The building was enlarged to the south in 1945, more than doubling the building's size, and occupying the site where St. Benedict's rectory had once stood.

The 1960s brought significant changes to St. Benedict's congregation. The city's new freeway system took the site of the school forcing the high school to close in 1964 when it had an enrollment of 84 pupils. The grade school closed in 1967 when it had 205 students. The hospital was transferred by the Capuchins to an independent non-profit group in 1966, which provided emergency care and drug and alcoholism treatment. The former hospital is now used as the Community Work Release Center and also houses the County Medical Examiner's offices.

Much of the original African-American congregation of St. Benedict's dispersed to other Catholic parishes as urban renewal and freeway construction destroyed the historic heart of the Black community causing it to disperse more widely throughout the city. It appeared that St. Benedict's would close. A meal program for the poor and homeless was then begun in the church basement, and members of the Justice and Peace movement began worshipping at St. Ben's. The congregation began to grow, and today numbers close to 200 members. In contrast to the past, most of the current members are Caucasian. St. Benedict's now sponsors a jail chaplainry program as one of its chief functions in addition to the large meal program.

The Architect – Erhard Brielmaier (January 7, 1841-August 29, 1917)

Erhard Brielmaier was born in Neufra, Wurtemberg, Germany on January 7, 1841 and came to this country with his parents when he was 9 years old. The family settled in Ohio, and Erhard learned how to draft plans and building from his father. Brielmaier married Theresa Haag in 1860, and the couple moved to Piqua, Ohio in 1865 where he opened an architectural office. They subsequently moved to Milwaukee in 1874 and within a few years Brielmaier's reputation as a church architect brought him commissions from all over the country. During his 50-year career, he reportedly designed over 800 churches, more than any other architect in the country, in every state of the United States and some in Canada.

The Brielmaiers raised 13 children and also adopted another child from Erhard's cousin's family. Of his nine sons, five went into the architectural firm, which was known as E. Brielmaier & Sons by 1887. Erhard died on August 29, 1917 at the age of 76. Brielmaier and his wife are buried in Calvary Cemetery near the chapel he designed there. Joseph M., Bernard A. (Ben), and Leo A. stayed in the firm the longest. The architectural practice was last known as Brielmaier Scherer & Scherer beginning in 1959. The last son to remain active, Leo A., retired from the firm in 1966 and died in 1969. The Scherer's retained the Brielmaier name through 1979, and their practice closed in 1984.

Brielmaier's contribution to the Old World character of Milwaukee lies mostly in the design of religious structures that emulate the European churches of our immigrant ancestors, especially those of German and Polish ethnicity. St. Josaphat's Basilica in Milwaukee (1896-1901), designed for the South Side Polish community, was Erhard Brielmaier's masterpiece. His firm also designed St. Casimir's Church (Polish), St. Michael's Church (German), and the beautiful woodcarvings of St. Anthony's Church (German), St. George Melkite Church (Syrian), as well as the gatehouse and chapel at Calvary Cemetery, the Grutza/Leszczynski building at 610 W. Lincoln, which reflects the boldness of Polish Baroque architecture, and the Rudzinski Building at 55-29 W. Mitchell Street.

IX. STAFF RECOMMENDATION

Staff recommends that the St. Benedict Roman Catholic Church at 924 W. State Street be studied for possible designation as a City of Milwaukee Historic Structure as a result of its possible fulfillment of criteria e-1, e-2, e-5 and e-6 of the Historic Preservation Ordinance, Section 308-81(2)(e), of the Milwaukee Code of Ordinances.

X. PRESERVATION GUIDELINES

The following preservation guidelines represent the principal concerns of the Historic Preservation Commission regarding this historic designation. However, the Commission reserves the right to make final decisions based upon particular design submissions. Nothing in these guidelines shall be construed to prevent ordinary maintenance or the restoration and/or replacement of documented original elements.

A. Roofs

Retain the original roof shape. Avoid making changes to the roof shape that would alter the building height, roofline or pitch. Retain the historic roofing materials on the church if at all possible.

B. Materials

1. Masonry

- a. Unpainted brick or stone should not be painted or covered. This is historically incorrect and could cause irreversible damage if it was decided to remove the paint at a later date.
- b. Repoint defective mortar by duplicating the original in color, style, texture and strength. Avoid using mortar colors and pointing styles that were unavailable or were not used when the building was constructed.

- b. Clean masonry only when necessary to halt deterioration and with the gentlest method possible. Sandblasting brick or stone surfaces is prohibited. This method of cleaning erodes the surface of the material and accelerates deterioration and the accumulation of dirt on the exterior of the building. Avoid the indiscriminate use of chemical products that could have an adverse reaction with the masonry materials, such as the use of acid on limestone or terra cotta.
- c. Repair or replace deteriorated material with new material that duplicates the old as closely as possible. Avoid using new material that is inappropriate or was unavailable when the building was constructed.

2. Wood/Metal

- a. Retain original material, whenever possible. Avoid removing architectural features that are essential to maintaining the building's character and appearance.
- b. Retain or replace deteriorated material with new material that duplicates the appearance of the old as closely as possible. Avoid covering architectural features with new materials that are inappropriate or were unavailable when the building was constructed.

C. Windows and Doors

- 1. Retain existing window and door openings. Retain the existing configuration of panes, sash, surrounds and sills, except as necessary to restore to the original condition. Avoid making additional openings or changes in existing fenestration by enlarging or reducing window or door openings to fit new stock window sash or new stock door sizes. Avoid changing the size or configuration of windowpanes or sash.
- 2. Respect the building's stylistic period. If the replacement of doors or window sash is necessary, the replacement should duplicate the appearance and design of the original window sash or door. Avoid using inappropriate sash and door replacements. Avoid the filling in or covering of openings with inappropriate materials such as concrete block or glass block. Avoid using modern style window units such as horizontal sliding sash in place of double-hung sash or the substitution of units with glazing configurations not appropriate to the style of the building. The leaded glass windows in the church should not be altered or removed except for restoration.

D. Trim and Ornamentation

There should be no changes to the existing trim or ornamentation except as necessary to restore the building to its original condition. Replacement features shall match the original member in scale, design and appearance, but not necessarily in material.

E. Additions

The south and east elevations of the church building are integral to the structure's architectural significance. Additions are not recommended and require the approval of the Commission. Approval shall be based upon the addition's design compatibility with the building in terms of height, roof configuration, fenestration, scale, design and materials, and the degree to which it visually intrudes upon the principal elevation.

F. Signs

The installation of any permanent exterior sign shall require the approval of the Commission. Approval will be based on the compatibility of the proposed sign with the historic and architectural character of the building.

G. Site Features

New plant materials, fencing, paving and lighting fixtures shall be compatible with the historic architectural character of the building.

St. Benedict the Moor Catholic Church

Milwaukee, Wisconsin



Basement Level Window Replacement Project

Appendix 3: Energy Audit Report (Rivion, 2020)

ENERGY AUDIT REPORT

**CAPUCHIN
COMMUNITY
SERVICES**

 Milwaukee
House of Peace
St. Ben's Community Meal

Saint Benedict Church, Annex, Meal Hall, Clinic & Friary

930 West State Street
Milwaukee, Wisconsin

PREPARED FOR

Brother Robert Wotypka
The Midwest Capuchins
1702 West Walnut Street
Milwaukee, Wisconsin

December 17, 2020

PREPARED BY



ASHRAE Level 2 Energy Audit

TABLE OF CONTENTS

INTRODUCTION.....	1
A. Building Documentation.....	1
B. Preliminary Energy Use Analysis.....	1
C. Walkthrough Analysis.....	1
BUILDING DOCUMENTATION.....	2
A. Building Operation Plan.....	2
B. Systems Narrative.....	2
C. Sequence of Operation.....	2
PRELIMINARY ENERGY USE ANALYSIS.....	3
WALKTHROUGH ANALYSIS.....	4
ENERGY USE PROFILE.....	5
OBSERVED ISSUES.....	8
Issue #1: Friary Window Installation.....	8
Issue #2: Saint Ben’s Meal Hall Window Operation.....	8
Issue #3: Saint Ben’s Church Window Operation.....	8
Issue #4: Thermostatic Control Valves.....	8
Issue #4: Church Entrance Door Seals.....	8
ENERGY CONSERVATION MEASURES (ECMS).....	9
CAPITAL IMPROVEMENTS.....	10
Capital 1: Lighting Upgrade.....	10
RECOMMENDATIONS.....	11
Item 1: Smart Thermostat replacement for Church.....	11
Item 2: Updated Mechanical Systems for Saint Ben’s Church and Meal Hall.....	11
Item 3: Updated Mechanical Systems for Friary space.....	11
APPENDICES.....	12
A. Building Operating Plan.....	12
B. Systems Narrative.....	20
C. Sequence of Operation.....	24

ASHRAE Level 2 Energy Audit

INTRODUCTION

The Energy Audit process implemented by Rivion is based on the steps outlined by the “Standards for Commercial Building Energy Audits” as published by ASHRAE.

This site consists of a group of buildings located at 930 West State Street Milwaukee, Wisconsin. Saint Benedict’s church is a 3,655 sqft worship space with a 6,635 sqft space located below and an associated 2,190 sqft Annex. The Church was completed in 1933, and the three story Annex was completed in 1923. The Friary consists of two connected buildings with a total area of 6,538 sqft. The connected three story buildings predate 1870. The Clinic is a 2,900 sqft three story clinic building predates 1860.

We reviewed the 2980 sqft Service Center, which was renovated in 2019. However, this building is not included in the ENERGY STAR® Portfolio Manager™ account.

The Capuchins organization has the goals of identifying operation savings and energy conservation measures.

A. Building Documentation

An important aspect of proper building operation is the availability of current building operation documents. During the audit process, Rivion will review the building documentation and provide templates for those documents needed.

B. Preliminary Energy Use Analysis

Rivion will review the property in ENERGY STAR® Portfolio Manager™ for accuracy in the logging of annual energy consumption.

C. Walkthrough Analysis

Rivion will perform a building walk-through survey to become familiar with building construction, equipment, operations, and maintenance. The team will meet with the owner / operator to learn of special concerns / needs of the facility. During the walkthrough, the team will identify low-cost / no-cost changes to the facility or O&M procedures. We will also identify capital improvements for further study.

ASHRAE Level 2 Energy Audit

BUILDING DOCUMENTATION

A. Building Operation Plan

See the Building Operation Plan describing the building occupancy hours and conditions located in Appendix A.

B. Systems Narrative

See the Systems Narrative describing the energy consuming systems located in Appendix B.

C. Sequence of Operation

See the Sequence of Operation describing the equipment operation describing the operation of the mechanical systems located in Appendix C.

ASHRAE Level 2 Energy Audit

PRELIMINARY ENERGY USE ANALYSIS

As part of the energy audit, Rivion helped the site team develop an ENERGY STAR Portfolio Manager (ESPM) account and review the building profiles. The building cannot achieve ENERGY STAR Certification due to the building type, but the Capuchin team should use the tools provided by ESPM to track building energy use.

RECOMMENDATION: It is recommended that energy utility consumption and demand data is updated in ESPM on a regular basis consistent with billing frequency. Energy is billed monthly for this facility. ESPM also has available water utility consumption tools for use at a future date.

Characteristic	Value
Year of Original Construction	1870/1923/1933
Building Climate Zone	6Z
Gross floor area, no parking	21,918 square feet
Total conditioned floor area	21,918 square feet
Total number of floors	3
Conditioned floors above grade	2
Conditioned floors below grade	1

Building Space Type	Floor Area	Percentage
Social Meeting Hall	6,635	16.68%
Residence Dormitory	6,538	29.83%
Worship Facility	3,655	30.27%
Urgent Care/Clinic	2,900	13.23%
Office	2,190	9.99%

Space ID	Saint Ben's Community Meal	Friary	Saint Ben's Church	Medical Office	Annex
Use	Social Meeting Hall	Residence Dormitory	Worship Facility	Medical Office	Office
Number Occupants	0	6	150	Vacant	2
Use (hours/week)	84	-	4	-	18
Use (weeks/year)	52	-	52	-	52

ASHRAE Level 2 Energy Audit

WALKTHROUGH ANALYSIS

Rivion conducted a walkthrough of the building spaces and mechanical systems. Due to the age of the buildings, little documentation is available.

We observed the mechanical areas to be well-maintained with regular inspections. Any issues with their recommended corrective actions are noted in the Issues section. We found the equipment to be well maintained when possible, and the condition to be consistent with the age of the equipment.

The Friary and Clinic.

During the walkthrough of the Friary buildings, we observed the mechanical spaces in the basement and the residential spaces. Due to the basic nature of the mechanical systems, there is limited area for improvement. We noted some issues with the installation of new windows in the issues section below. The buildings have insulation installed, but the level of insulation present is difficult to determine.

Saint Benedicts Church, Meal Hall, and Annex

Due to the age of the mechanical systems and control systems, there is limited opportunity for low cost ECMs at this facility. The original ventilation system for the church has been abandoned and is no longer in use. The site team has upgraded the lighting in the Meal Hall to LED with some lighting upgrades in the church space. The windows in the spaces are original construction, and some issues were noted with their operation.

Saint Benedicts Service Center

Given the recent renovation of the space, we found the areas to be in good condition. The area has new fan coil units with networked thermostats. LED fixtures are installed in all areas of the service center.

Upon completion of the documentation review, on-site walk through, and inspection of the mechanical, lighting and control systems, Rivion identified some opportunities for no-cost / low-cost energy conserving measures (ECMs.) The implemented ECMs and their estimated savings are listed in following sections.

ASHRAE Level 2 Energy Audit

ENERGY USE PROFILE

Rivion performed an Energy Audit at St. Ben's Campus on October 26, 2020 with the goal of identifying opportunities to improve energy efficiency and other ways to reduce energy.

EPA ENERGY STAR Score:

The facility is not eligible for ENERGY STAR Score due to the building usage type. Energy use will be referenced using Site Energy Use Intensity

The Site Energy Use Intensity (EUI) is the Site Energy divided by the property square foot. Site Energy is the annual amount of all the energy your property consumes onsite, as reported on your utility bills. Use Site Energy to understand how the energy use for an individual property has changed over time. The current and baseline site EUI's are noted in the table below.

Energy Score	12-month End Date	ENERGY STAR Score	*Site Energy Use Intensity (EUI in kBtu/sf)
Current	05/30/2020	-	102
Baseline	12/31/2009	-	109

*Site EUI does not directly correlate to ENERGY STAR Score

Current Electric Meters (per ENERGY STAR Portfolio Manager):

ESPM Meter Name	Meter Type	Meter Usage Units
Electric Grid Meter 3227477575	Electric - Grid	kWh
Electric Grid Meter 5611546112	Electric - Grid	kWh

Current Gas Meter (per ENERGY STAR Portfolio Manager):

ESPM Meter Name	Meter Type	Meter Usage Units
Natural Gas 5611546112	Natural Gas	Therms
Natural Gas_8260635503	Natural Gas	Therms

Current Steam Meter (per ENERGY STAR Portfolio Manager):

ESPM Meter Name	Meter Type	Meter Usage Units
District Steam 2855541349	District Steam	kLbs.

ASHRAE Level 2 Energy Audit

Table: Total Energy 2009 – Baseline Year

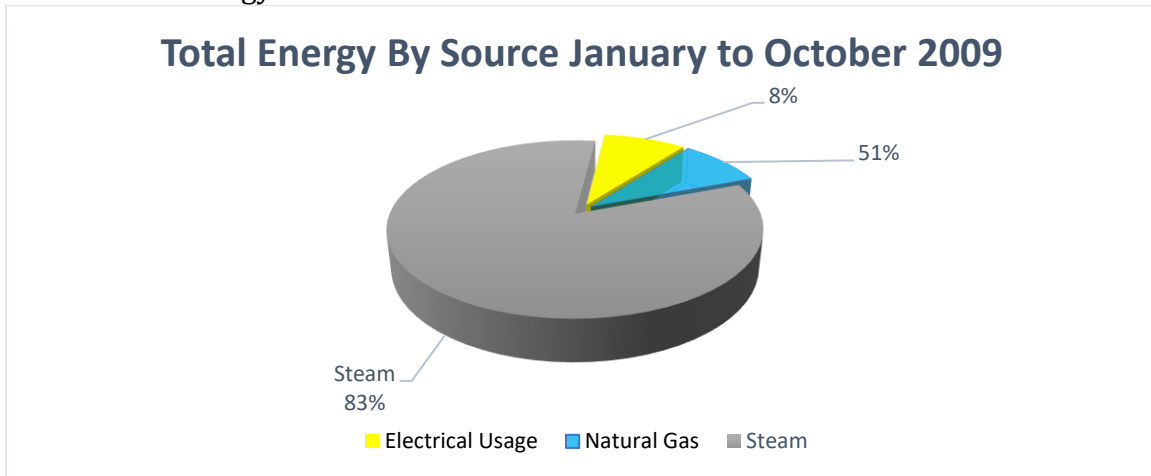
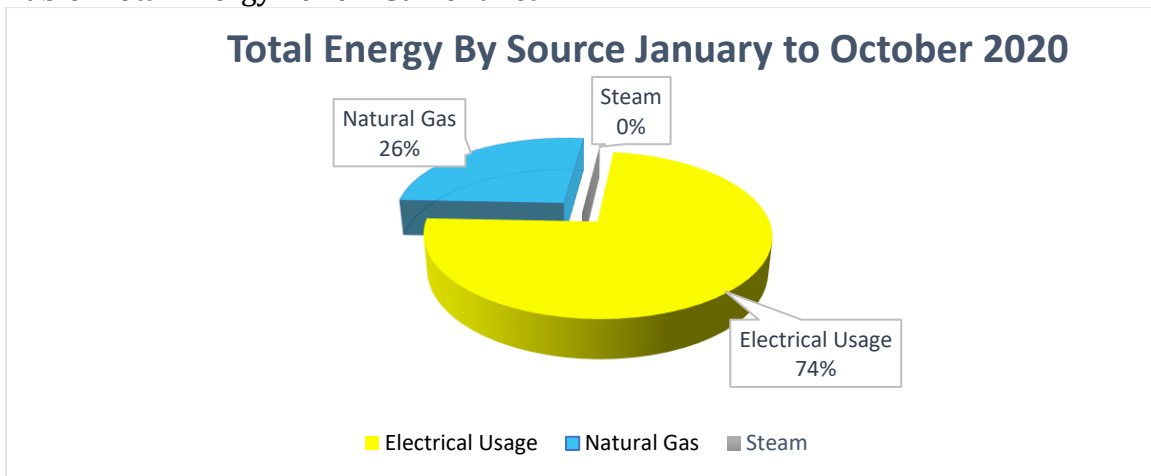

Table: Total Energy 2020 – Current Year



*Note: no steam data is available for 2020 comparison

ASHRAE Level 2 Energy Audit

Table: Total Electrical Consumption

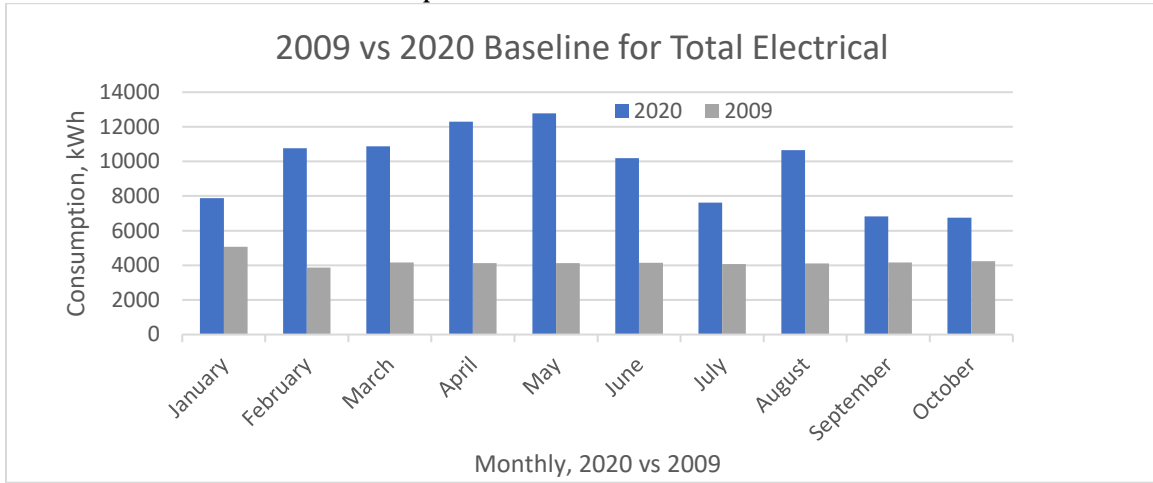
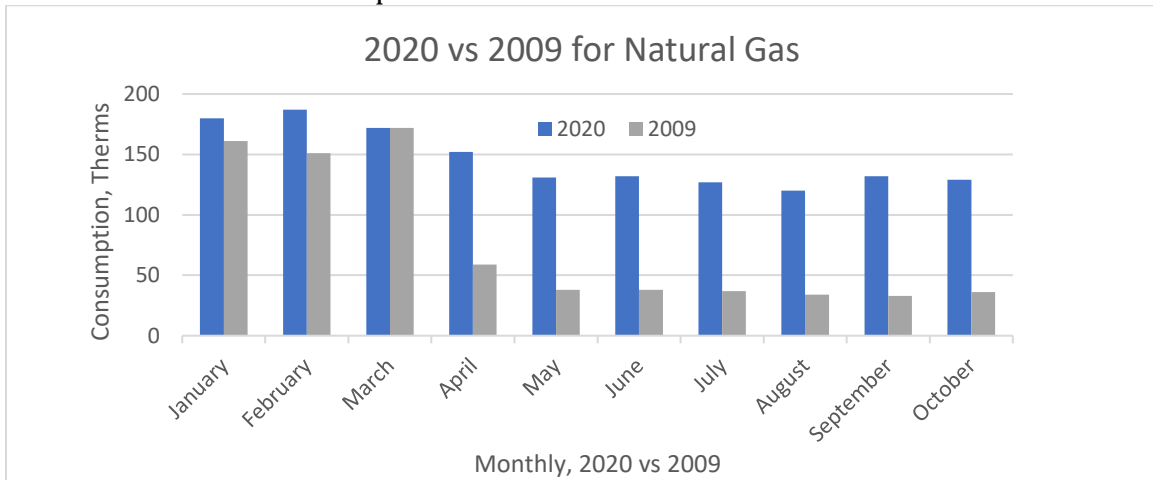

Table: Natural Gas Consumption



*Note: the 2020 values indicate meter issues.

ASHRAE Level 2 Energy Audit

OBSERVED ISSUES

Issue #1: Friary Window Installation.

Location: First Floor, Second Floor

Description: Some windows appear to be improperly sized and/or installed. Gaps are visible at the edges of the window frames. This can lead to excess infiltration of air and moisture.

Recommended action: Have an insulation contractor review and provide a budget to correct.

Issue Status: Open

Issue #2: Saint Ben's Meal Hall Window Operation.

Location: Meal Hall

Description: Some windows do not close properly or completely. This can lead to excess infiltration of air and moisture.

Recommended action: Have a window contractor review and provide a budget to correct.

Issue Status: Open

Issue #3: Saint Ben's Church Window Operation.

Location: Church

Description: Some windows do not close properly or completely. Two units were noted as not closing properly. This can lead to excess infiltration of air and moisture.

Recommended action: Have an installation contractor review and provide a budget to correct.

Issue Status: Open

Issue #4: Thermostatic Control Valves

Location: Annex, Church

Description: Several thermostatic control valves noted as not operating properly. At least five were noted with this issue.

Recommended action: Have mechanical contractor survey all radiator controls and provide a budget to repair/replace.

Issue Status: Open

Issue #4: Church Entrance Door Seals

Location: Church

Description: The door seals have aged and failed. Light is visible through gaps.

Recommended action: Have new seals installed.

Issue Status: Open

St. Benedict the Moor Catholic Church

Milwaukee, Wisconsin



Basement Level Window Replacement Project

Appendix 4: Marvin Windows Product Data

ULTIMATE

MARVIN SIGNATURE® COLLECTION



ULTIMATE DOUBLE HUNG G2

Engineered for performance and designed to inspire, each aspect of the Ultimate Double Hung G2 window was made with purpose. Our engineers consider every detail from the most innovative features to the most minute subtleties, all because the windows in your home help illuminate the most important parts of your life.

INTERIOR FEATURES AND PERFORMANCE

RICH WOOD INTERIOR

Offers beauty and warmth with six wood species and ten interior finish options.

NARROW CHECKRAIL

Provides a sleek aesthetic at 1 5/16 inches to maximize daylight opening while maintaining historical accuracy.

TILT WASH

Allows easy access to exterior glass for cleaning and maintenance.



EXCLUSIVE AUTOLOCK

Activates when the sashes are closed, locking the window.

FIRST-RATE ENERGY EFFICIENCY

Meets ENERGY STAR® standards in energy efficiency with multiple glass options for various regions, climates, and weather needs.

SASH BALANCE SYSTEMS

Enables smooth operation at the largest sizes.

EXTERIOR FEATURES AND PERFORMANCE

DURABLE CLADDING

Extruded aluminum exterior cladding with an AAMA verified 2605 finish and backed by a 20-year warranty against chalking and fading

EXPANSIVE SIZES

Larger than 5 feet wide by 10 feet high.

TRADITIONAL SILL BEVEL

The 14-degree bevel provides optimal water management while maintaining a classic look.

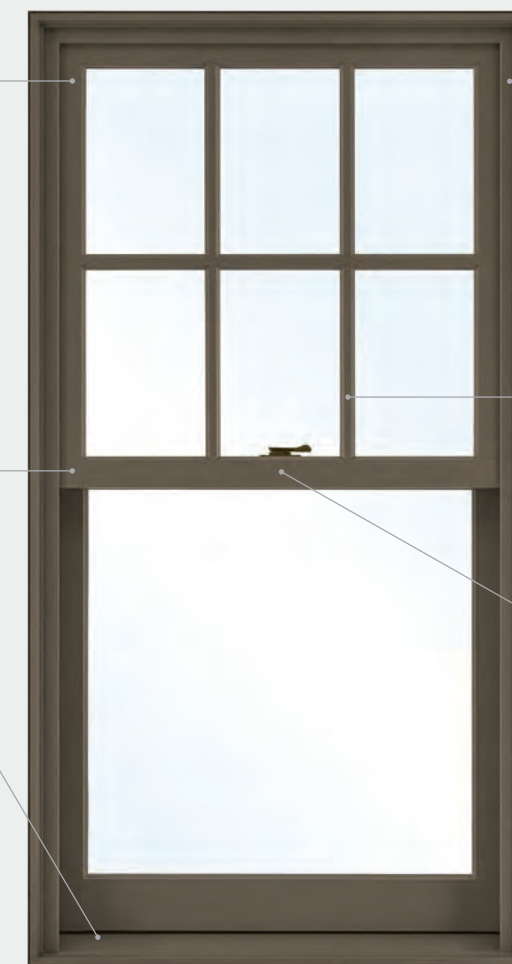

SUPERIOR WEATHER PERFORMANCE

LC-PG50 on most sizes. Optional commercial (CW) performance and IZ3 certified coastal performance on most sizes.

DESIGN VERSATILITY

An array of simulated divided lite patterns, interior and exterior color options, ten hardware finishes, and archtop models.

ALUMINUM INTER-LOCK

Eliminates drafts and improves the window's overall structural integrity.

ULTIMATE SINGLE HUNG G2



Single Hung G2 window with Traditional Lift Lock in Satin Chrome



Single Hung G2 windows with Contemporary Lift Lock in Brass

ULTIMATE SINGLE HUNG G2

A contemporary classic, the Ultimate Single Hung G2 window blends traditional beauty and state-of-the-art performance. With the top sash stationary and the bottom sash operable, a single hung style is often preferred in a cottage-style window with a small top sash that doesn't need to open. Reliable and energy efficient, the Ultimate Single Hung G2 window offers an auto-lock feature for convenient security, durable hardware for smooth operation, and Marvin's unique Wash Mode for easy cleaning. Customize your design with round top styles or optional Lift Lock, Marvin's exclusive bottom rail locking mechanism for easier operation in hard-to-reach areas.



INTERIOR VIEW WITH CONTEMPORARY LIFT LOCK



INTERIOR VIEW WITH TRADITIONAL LIFT LOCK

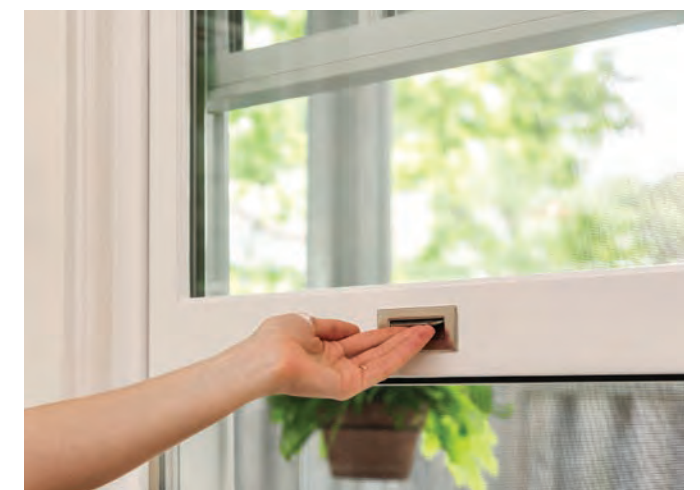

CONTEMPORARY LIFT LOCK OPERATION SHOWN IN SATIN NICKEL

INTERIOR FINISH OPTIONS

PINE

**VERTICAL GRAIN
DOUGLAS FIR**

**MIXED GRAIN
DOUGLAS FIR**

CHERRY

WHITE OAK

HONDURAN MAHOGANY

MAPLE
Custom option

BLACK WALNUT
Custom option

WOOD SPECIES

Offering a rich, warm look, many custom options, and design versatility, wood is a premium choice. Wood can be used on both the interior and exterior of our Ultimate windows and doors. As a lower maintenance option, wood can also be used on only the interior with an extruded aluminum cladding exterior. Marvin offers both options, leading the industry in sourcing, processing, and utilizing high-quality wood.

STAIN + PAINT

When compared to painting or staining on the job site, factory-stained finishes offer consistent quality and performance resulting from our expertise with wood as a material and years of perfecting our finishing processes.

Painting on the job site or scheduling off-site finishing is an extra step that takes time and coordination. Choose our painted interior finish option on any Marvin windows and doors with a wood or clad exterior for a factory-painted option that arrives ready to install.



EXTERIOR FINISH OPTIONS

STONE WHITE

COCONUT CREAM

SIERRA WHITE

CASHMERE

PEBBLE GRAY

HAMPTON SAGE

CADET GRAY

CLAY

CASCADE BLUE

SUEDE

GUNMETAL

WINEBERRY

BRONZE

BAHAMA BROWN

EVERGREEN

EBONY

BRIGHT SILVER (PEARLESCENT)

COPPER (PEARLESCENT)

LIBERTY BRONZE (PEARLESCENT)

CUSTOM COLOR: ANY COLOR YOU WANT

EXTRUDED ALUMINUM

Extruded aluminum is an extremely tough cladding that protects wood windows, mimics the profiles of wood, and provides superior durability. It is the most commonly ordered exterior material for our Ultimate products.

Select a color from our palette of 19 durable extruded aluminum colors, including a spectrum of rich hues and three pearlescent finishes. If you have more specialized needs, we can also work with you to create a custom color.

WOOD

Wood is a premium material for windows and doors, offering classic aesthetic appeal, many options for customization, and design versatility.

We treat exposed millwork with a water repellent wood preservative to help it last longer. Choose from one of the four options below. Each is ready to be finished to match your project's exacting requirements.

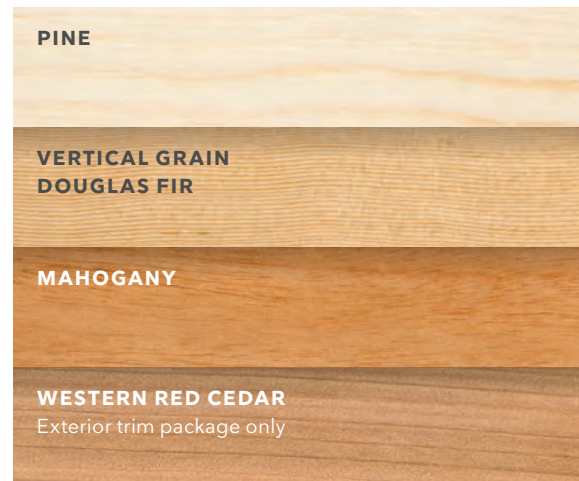

Ultimate Double Hung G2 window in Ebony

Ultimate Double Hung G2 window in Suede



DIVIDED LITES



Casement windows with custom Simulated Divided Lites

DIVIDED LITES

Simulated divided lites, available in a number of different styles, mimic the look of individual panes of glass with the energy efficiency of dual pane insulated glass.

Our custom capabilities allow us to create almost any divided lite pattern to match your design style.



SIMULATED DIVIDED LITE (SDL)

SDL bars are permanently adhered to both sides of the glass. Simulated Divided Lites with Spacer Bars (SDLs) are an energy-efficient way to create the look of authentic divided lites.



AUTHENTIC DIVIDED LITE (ADL)

Separate panes of glass are glazed between muntin bars for historical accuracy. Available exclusively with wood exterior units.

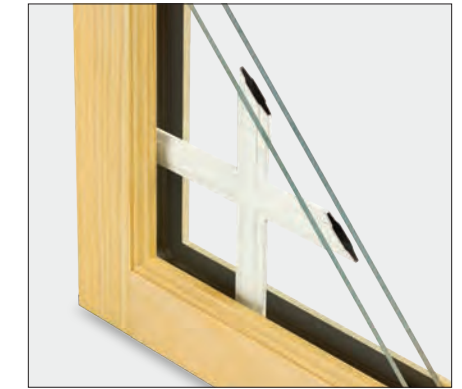

GRILLES-BETWEEN-THE-GLASS (GBG)

Grilles are permanently installed between the glass panes. This low-maintenance grille offers the look of a divided lite pattern with the ease of cleaning just one pane of glass. Available with different interior and exterior colors.

FIVE STANDARD BAR WIDTHS

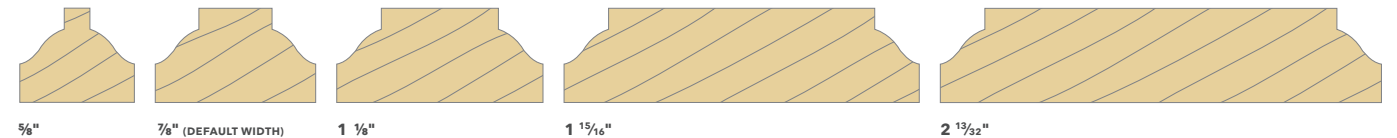

SQUARE STICKING

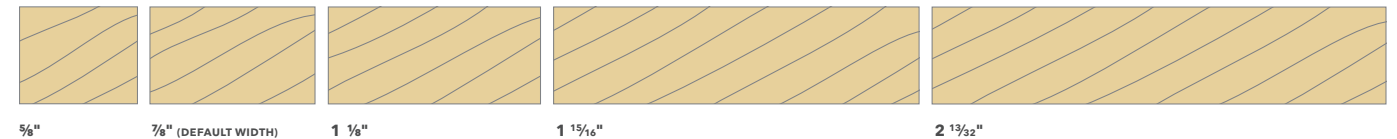

MARVIN SIGNATURE® COLLECTION

STICKING AND PROFILES

Sticking refers to the interior profiles of your wood window. Choose from the standard Ogee profile (used on traditional projects) or the optional clean, contemporary Square sticking.



OGEE



SQUARE



SQUARE STICKING

GLASS + GLAZING



Awning and Picture windows and Outswing French door

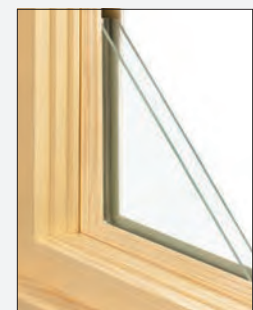

DUAL PANE GLAZING

Our standard glazing is dual pane: two panes of glass with Low E coatings and insulated with argon gas. Compared to a single glass pane, dual pane glass cuts energy costs significantly because of low emissivity coating and the gas filled insulating space between the glass layers.



TRIPLE PANE GLAZING

Triple pane glazing consists of three panes of glass with Low E coatings applied to the surface. Two glass spaces are insulated with argon gas between the panes. Available in products where glazing thickness can be greater than 3/4 inch.

GLASS + GLAZING

The thermal and structural properties of wood combined with the right glazing make Marvin wood and extruded aluminum clad products an optimal choice for energy efficiency. We offer thousands of window and door options with two or three panes of glass and a range of glazing options to meet the performance challenges of any climate.

GLASS COATINGS

Low E coatings are microscopically thin, essentially invisible coatings on the glass surface that help manage the amount of light and heat conducted through a window pane or reflected away from it, reducing a home's dependence on heat and air conditioning. The national ENERGY STAR® program recognizes products that meet strict energy-efficiency guidelines to suit climates in different areas of the country, and Marvin offers products to meet climate and code requirements in every region.

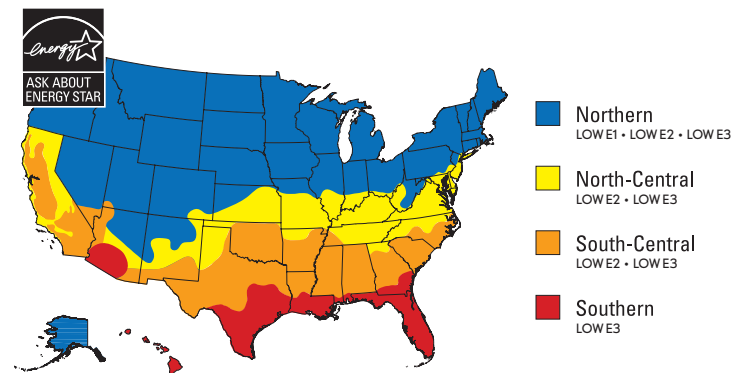

LOW E1

Low E1 coating is a good choice when you want maximum solar heat gain and radiant heating properties. This type of coating is generally used in Northern climates where heating is prioritized over cooling. You'll reap maximum benefits when windows with this type of coating are positioned to receive direct sun exposure.

LOW E2

The most common Low E coating since it works well across most geographic regions and climates. Low E2 with two metallic coatings balances less solar heat gain and improved radiant heating properties.

LOW E3

Used in applications where solar heat gain may be a concern, low E3 coating uses multiple metallic layers for radiant properties similar to Low E2. This type of coating is most commonly used in Southern, sunny climates where cooling is prioritized over heating.

SPECIALTY GLASS

Our specialty options include glass for unique project needs like sound abatement (STC/OITC), high altitudes, Sea Turtle Conservation Codes, and California fire zones. We also offer laminated glass on certain products that are designed specifically for hurricane zones.

A variety of decorative glass options, including those shown below and others, are available to meet the unique needs of each project. Laminated glass is also available in clear, bronze, gray, or green with tinted interlayers.

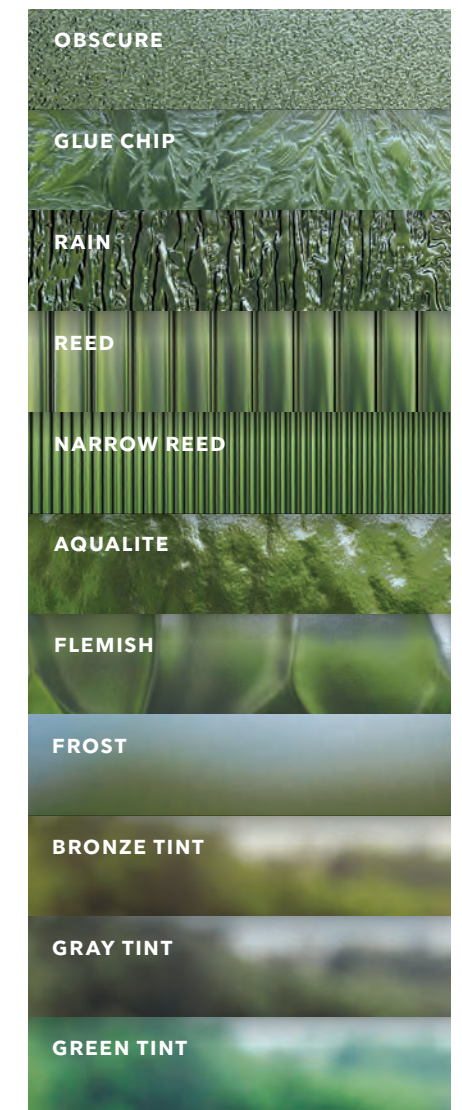

Section Details: Operating

Scale: 3" = 1' 0"

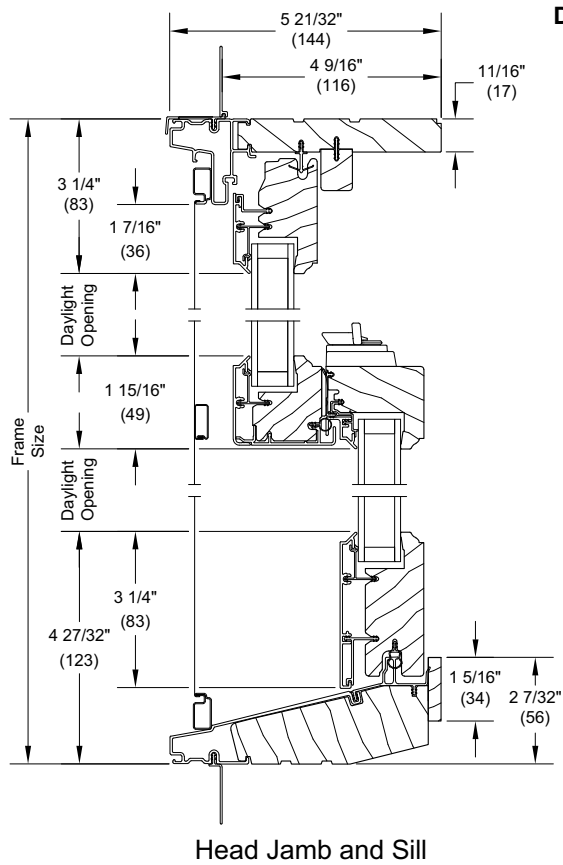

Double Hung

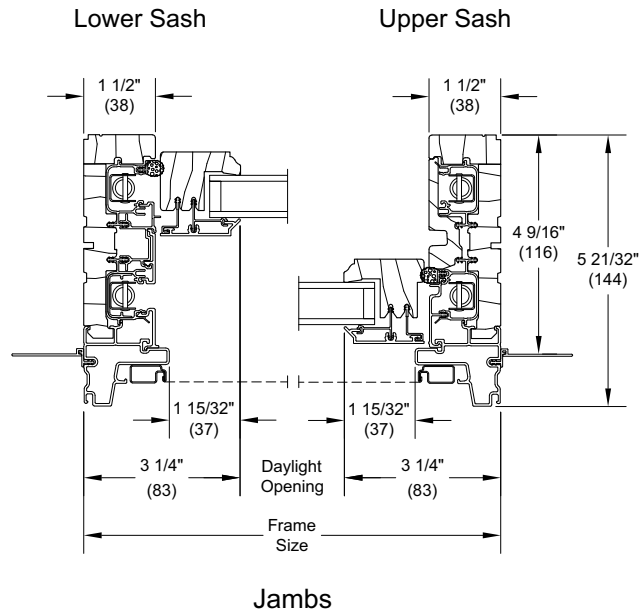

Single Hung

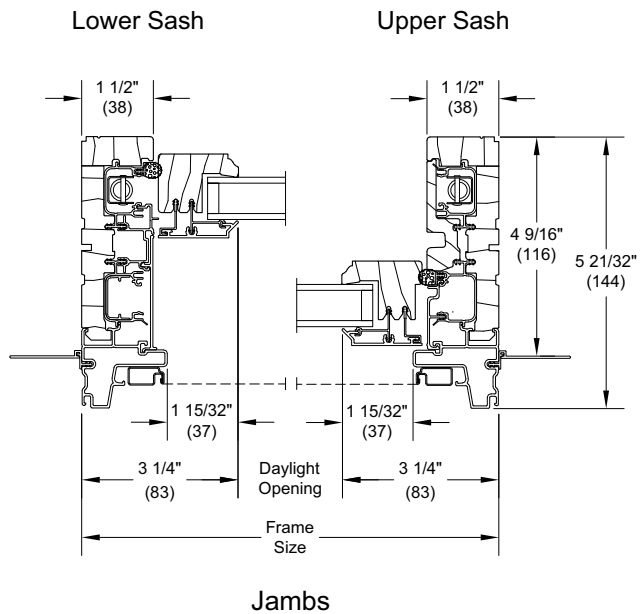
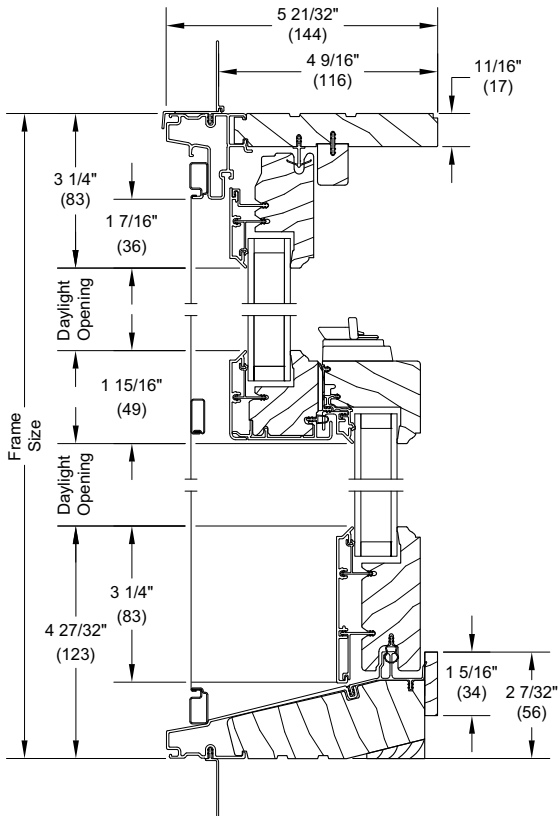

Lite Options

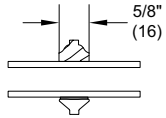

5/8" SDL

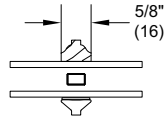

5/8" SDL
W/Spacer

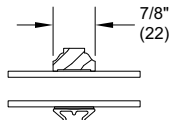

7/8" SDL

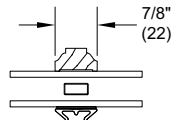

7/8" SDL
W/Spacer Bar

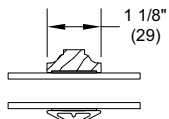

1 1/8" SDL

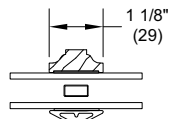

1 1/8" SDL
W/Spacer Bar

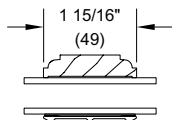

1 15/16 " SDL

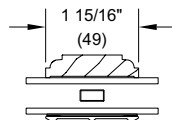

1 15/16 " SDL
W/One Spacer Bar

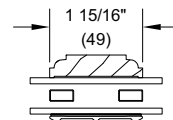

1 15/16 " SDL
W/Two Spacer Bars

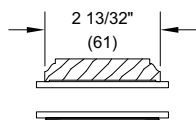

2 13/32" SDL

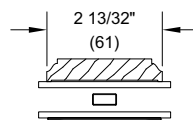

2 13/32" SDL
W/One Spacer Bar

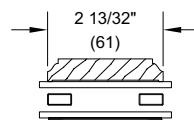

2 13/32" SDL
W/Two Spacer Bars