

MPL BINDERY REPORT 2007

1. The Milwaukee Public Library opened its doors in 1899. The Bindery opened shop in approximately 1903. The Bindery has been a working, functioning and necessary part of Library services for in-house needs as well as the general public.

a. 100 years of service

b. All Library departments use bindery services for various needs

c. Repair services are used by all 12 Branch Libraries

d. Patrons use our bound periodicals for research and new books for many various reasons, including repaired material that was broken and now, thanks to the Bindery, is back in circulation.

e. The Bindery hit its peak in the 1960's with over 20 employee's on staff. In 1982, when I joined the staff, there were only 9 people left. Now we have 3 Bindery employees, and we are fighting to keep our staff in tact at this level.

2. The Bindery Mission is two-fold:

a. The preparation of new material for distribution within the Library to also be used by the public and

b. Bookbinding (see attached information B)

3. The flexibility required and given by the Bindery staff to please management and cope with the changes, demands and expectations over time, has been extensive. We have been through TQI, overhauled, and streamlined the Bindery. We have gone through many changes. Some imposed upon us and many by our own initiative. We, in the Bindery, can say, with pride, that we have accomplished our best for MPL.

4. **(Please see color equipment pages)**

Bookbinders at MPL Bindery have taken the initiative to upgrade our skills in operating and maintaining the departments equipment. In the past, the Bindery manager and lead bookbinder were designated to maintain certain machinery. Now, all bookbinders clean, repair and maintain all of the Bindery equipment. In addition, over the last five years, the Library has purchased expensive new equipment for the Bindery enabling us to upgrade our ability to produce a quality product. The Library, by doing this, has shown interest in keeping the Bindery healthy and productive well in to the future.

MPL BINDERY REPORT 2007 (cont.)

5. The Bindery has the complete support of MPL's Librarian Staff. They realize that an in-house Bindery provides many arcane and varied services beyond binding a book.

(See attached Info B.)

MPL Bindery currently binds approximately five thousand titles per year. If Jim's position is eliminated, we will be held to binding under one hundred titles per year. Bookbinding at MPL will, in any practical assessment, come to an end. All of the unbound material will be packed in boxes and stored in the Library's basement.

6. Quality comes at a cost beyond dollars and cents. For a public institution, as is the Library, it is essential to keep all of its departments in tact so that the Library can maintain an ongoing level of quality service mandated by our city's founding fathers who had the vision and foresight to make this institution **public not private** and to endow the Library with departments, like the Bindery, so that it can operate in a self-sufficient manner whenever possible.

For the sake of all patrons that depend on this important institution, and for the sake of a healthy and vibrant Library, we ask you to restore Jim's position in the 2008 budget and make us whole once again.

Thank you.

2, info B

An in-house bindery benefits library and public needs in so many varied and essential ways, some of which cannot be gotten through outside sources.

1. An in-house bindery provides easy access to materials in the binding process.
2. Quality workmanship : all bookbinders working in the library bindery learned their craft through a four- or two-year apprenticeship program. All bookbinders in MPL by virtue of their experience in library bookbinding can be considered Master Bookbinders.
3. One-day turn around service (including new or rebound materials)
4. In-house binding provides the ability to retrieve material a patron may have an immediate need for.
5. Special projects: our bindery provides custom-built boxes, wing binders, portfolios, pam binders, etc.
6. The bindery supplies cut paper stock for the MPL print shop.
7. The bindery maintains the library's huge collection not only through the binding process but also through the use of preservation techniques such as acid-free binder-board and other binding materials.
8. We bind newspapers at no additional cost.
9. MPL bindery has initiated a book repair program that has saved the city the cost of rebinding thousands of books that would have in the past been rebound.
10. MPL bindery initiated TQI concepts through streamlining the department years before the current push for TQI throughout the city.
11. MPL bindery stands ready now as it did in the past to provide bindery services for other city departments as well as county departments, MPS, etc.
12. MPL bindery costs are competitive with commercial binding, also keeping city monies spent here in the Milwaukee community.



Now, for the first time, you can profitably do a production run of 1, 10, 100 or 1000 Perfect bound books! There are no set-up costs or turnaround times. These books can be made on demand, while your customer is waiting. And there is no waste — each book you make is a good one.

3 STEPS TO PERFECT BINDING



BIND

The new Fastback® Model 15xs document binder is the first step in the binding process. Coupled with our Scorer, and Perfectback™ strips, you can bind professional-looking paperback books with ease and speed.

First, BIND your document pages with the proper Perfectback™ strip in the Model 15xs. This binder is fast and easy to use. It incorporates the latest in document recognition technology. Depending on the binding style you choose, and the document's thickness, the binder automatically adjusts the temperature and bind time to give you the strongest possible bind.

- Strong hold, durable bind
- Document opens flat
- Binds 3-350 pages
- No punching or drilling
- Easy to use
- Binds within 25 seconds

PAPER CUTTERS

305 & 370 XT

Maximize productivity by storing jobs on 99 channels — a 47,000 total cut memory! This Champion provides the ultimate in productivity, with 30½" or 37" cutting width, plus fully computerized operation and system monitoring. You are in complete control with our distinctive, touch-screen color display which visually diagrams cutting patterns and monitors job progress as well as cut dimensions. Designed and supported by Challenge with floppy disk port and Windows-based upgradeable software to keep you ahead of the competition.

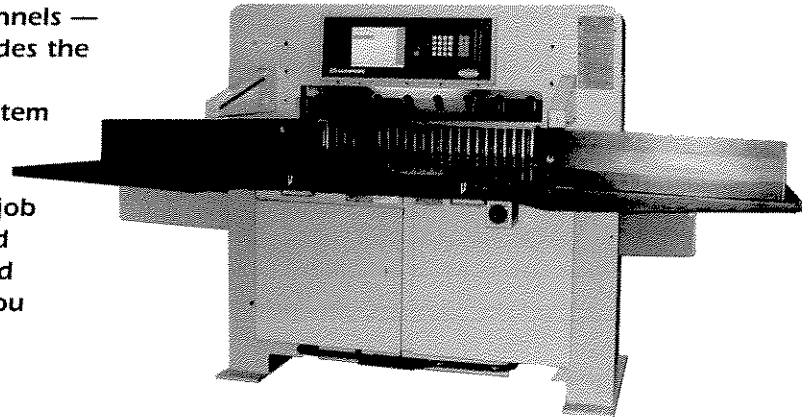

305 & 370 XG

Our best-selling cutter just got better! With 30½" cut width/4" clamp opening or 37" cut width/5½" clamp opening, these cutters deliver rugged construction, hydraulic clamping and cutting, electronic clamp pressure control, and variable speed pinpoint backgauge control. Outfitted with dual LCD screens to efficiently position, program, and monitor all aspects of your cutting operation. 99 channel, 9,801 total cut memory. Boost your productivity with the addition of a Champion 305 or 370 XG!

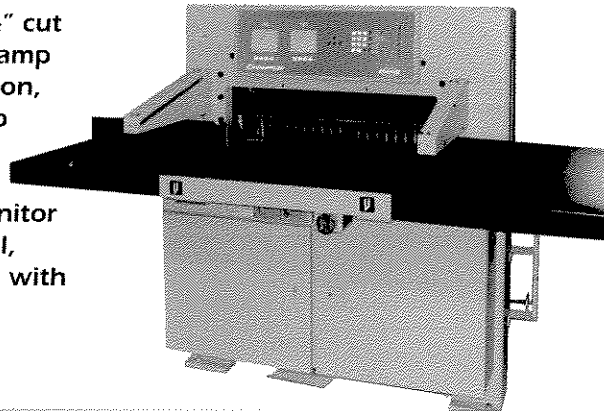

EQUIPMENT PURCHASE AGREEMENT

For: Milwaukee Public Library
814 W. Wisconsin Avenue
Milwaukee, Wisconsin 53233

July 20, 2004

EQUIPMENT

• Challenge Model 370-XG, 37" Cutter with Programming and Air Table	\$ 36,995
• Less Discount	< 3,363 >
• Freight, Installation	1,760
<hr/> Total	<hr/> \$ 35,392

P. Potdevin 1998

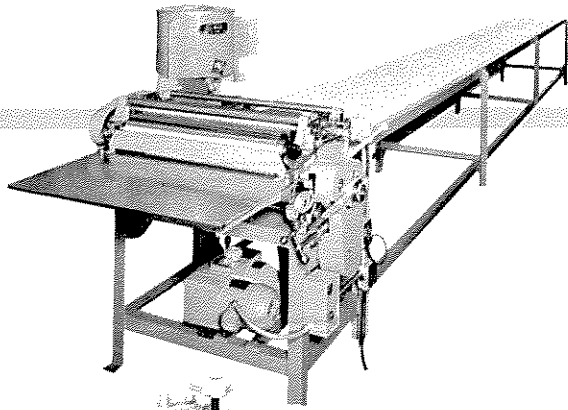

Conveyor Gluers

Save time, cut production costs with a versatile Potdevin Conveyor Gluer. Ideal for strip gluing, the machine will handle virtually any flat surface, regardless of shape. Potdevin Conveyor Gluers are used extensively for bookbinding and paper box manufacturing. Other applications include file folders, luggage, toys and games, sample cards, novelties. Sixteen-foot belt conveyor supplied; additional eight-foot sections available. Machine widths are 21, 28, 36 and 44 inches. Electric heater for hot animal glue optional.

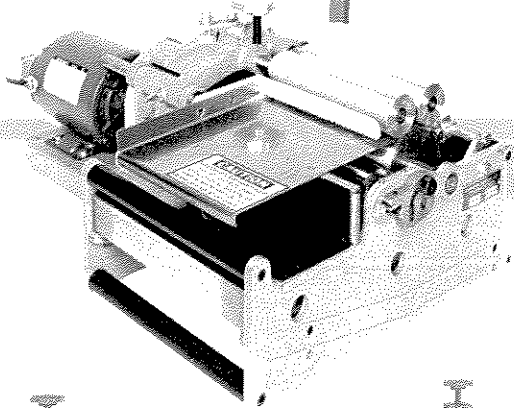

Edge Gluers

Reduce edge gluing costs as much as 50% with a Potdevin Edge Gluer. Adjustable to accommodate materials up to an inch thick, the Edge Gluer can apply a strip of adhesive to the edge of material from 1/4 of an inch to the width of the coating roller. Available in roller widths of 1, 2, 4, 6, 8, 12 and 15 inches. Top- and bottom-side coaters can also be made to order. Electric heater for hot animal glue optional. Higher temperature "Hot Melt" models are also available.

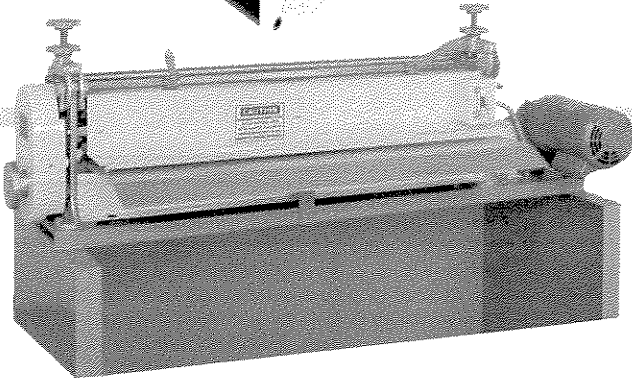

Rotary Press

Excellent for high-speed laminating of glued materials, flexible or rigid, up to a half inch in thickness. Uses include chipboard to chipboard, litho labels to chipboard or corrugated boxes. Adjustable pressure. Available in widths of 24, 30, 36, 42, 48, 54, 60 and 70 inches.

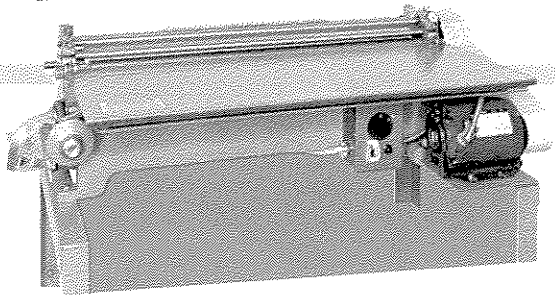

Sheet Coating & Gluing Machine

Automate your gluing of paper, cardboard and many other materials with the Potdevin Type Z Gluer. Fast, accurate applications. Available with brass or stainless steel rollers, single-pressure roller for thick materials. Optional attachments for strip gluing, cardboard gluing. Sizes: 21, 27 and 32 inches. Electric heater for hot animal glue optional.

2006 Carry Over

<u>Office Furniture</u>	<u>Location</u>	<u>Account</u>	<u>Amount</u>	<u>Expenditure</u>	<u>Balance</u>
Chairs (34)	System	680505-8611	\$15,863.31		\$15.81
				\$4,301.56	
				\$641.07	
				\$10,904.87	
<u>Miscellaneous</u>					
Glue Machine	Bindery	689000-8611	\$10,007.00	\$9,911.82	\$95.18

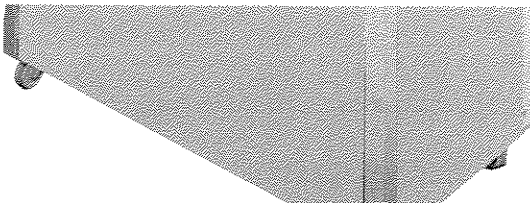

* OPTIONAL DELUX FLOOR STAND

3300 N. Newhall St.
Milwaukee, WI 53211
September 20, 2007

Finance and Personnel Committee
Milwaukee Common Council
City Hall
Milwaukee, WI 53202

Dear committee members:

As a librarian at Milwaukee Public Library for twenty-three years, I'm writing in support of retaining the library's bookbinder position that has been slated for elimination.

Aside from the money saved from having an in-house bindery, we librarians have been consistently impressed by the speed, workmanship and accessibility of our bindery.

We often have materials in need of quick repair, e.g., a one-of-a-kind print reference source at Ready Reference, and sending the material out of house for rebinding is not a good option. The turn around time for these outside binderies would impinge on us being able to offer the kind of speedy reference work Ready Reference is noted for. Our bindery has been especially helpful in returning these important reference sources to us in a most timely fashion.

The bindery has also been very accommodating in helping preserve our local history resources. Old Milwaukee city directories and phone books, which are used on a very frequent basis by our patrons, have been kept in good condition because of our bindery's excellent work. Local newspapers have also been preserved in unique, tried-and-tested bindings that would be hard to replicate by an outside firm – and certainly not at the low cost our bindery provides.

While we may be one of the last large public libraries to have an in-house bindery, I've had occasion through my dealings with other librarians around the state to hear comments about how fortunate we are to have an in-house bindery, and how inadequate and frustrating outsourcing bindery material can be.

The bindery staff has gone from nine to three over the last fifteen years. The work that they continue to do is of great value to the city. Savings predicted by eliminating one of the bindery positions will surely be a phantom. We'll end up paying more and getting less. Please save this position.

Sincerely,

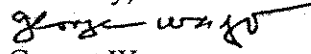
George Wagner
Librarian III
Humanities Department
Central Library

Cuts in Bindery Staff

The Humanities Department relies on the MPL Bindery to repair its rare and fragile books. The Milwaukee City Directories, family histories, and one-of-a-kind books of historical significance are irreplaceable. We have also depended upon the Bindery to preserve the historical and genealogical magazines by binding the issues together so that individual issues are not lost or stolen. Only a few of these titles will be bound if the staff is cut. And I am concerned that staff cuts will also make it more difficult to have our books repaired and quickly returned the way they are now. I hope that the City of Milwaukee will find a way to preserve all of the few remaining Bindery jobs, which have been reduced so much already during the years I have worked at the Milwaukee Public Library.

Sincerely,



Richard Swearingen
Local History and Genealogy
Humanities Department
Milwaukee Public Library

Having an in-house bindery has provided multiple benefits to the library system. Every day the library acquires the best of print materials, provides free access to them and preserves them for the citizens of Milwaukee now and for the future. Binding books and periodicals that have lasting value maintains our commitment to our patrons. Binding periodicals helps to safeguard them against theft and also increases patron access to these materials. Allowing the most popular back issues to be available in a self-serve arrangement enables browsing and increases usage. The articles alone are not always what people want to read; it's the ads, letters to the editor, charts, and tables that are not available via electronic access. PDF format does provide full access to the articles, but many periodicals have only HTML text.

Some of the most important materials to be preserved are those with local information. The format of local documents, newsletters, and other print sources are vulnerable to physical harm if not bound. Many of these types of materials are not available electronically.

On-site binding has saved the City tens of thousands of dollars over the years and has enabled the library to create a treasury of materials represent now over 100 years of mankind's knowledge, discovery, adventure and imagination.

October 5, 2007

To whom it may concern:

Regarding the transfer of a skilled trades employee.

The proposed transfer of a skilled trades employee in the bindery to a circulation position seems a waste of talent. I realize that the budget and the library must change with the times, but it would be more logical and efficient to transfer a person who is already doing work that is similar to the work in the new assignment.

As the entire bindery department consists of only three seasoned staff, wouldn't it make more sense to let attrition reduce the staff there? All the employees in this department are skilled workers with many years of service.

I know that government sometimes believes outsourcing is more cost effective, but many times they find quality suffers and costs are raised by having to do over tasks that a staff member would have done right the first time. In addition, when work is outsourced without government oversight abuses can occur. Just a few weeks ago an article in a Madison newspaper emphasized this point. The caption read "The CDA has been spending an unconscionable amount of money on things that union personnel should be doing." CDA is Madison's Community Development Authority.

If changes must be made it would be wise to study the types of tasks performed so that the library and the public receive the best service for the money spent. We should be using each staff member's strengths and skills, rather than underutilizing them.

Thank you for your consideration of these suggestions.

From a
Staff member in the Technical Services Department at Milwaukee Public
Library

School & Library Price List

REBINDS or Monographs

-Bound in random colors* - Up to 12"
 24 or fewer \$19.25 per volume
 25-49 \$10.95 per volume
 50 or more 8.95 per volume

TEXTBOOKS

- Bound in random colors*/sets in same - Up to 12"
 24 or fewer \$19.25 per volume
 25-49 10.65 per volume
 50-99 8.75 per volume
 100-199 8.25 per volume
 200+ 7.25 per volume

All prices include up to 8 lines of lettering on spine
 *Specific buckram colors available at +.30 per vol.
 Full color copy covers available for +3.25 per vol.
 Additional color copy covers for a set +2.50 per vol.

MAGAZINES or Serial Volumes

Top of the line binding Up to 12"

10 or fewer \$22.95 per volume
 11 or more 18.75 per volume

Price includes your choice of how the journal is organized, cover color, stamping color and up to 8 lines of lettering. Ad stripping is extra.

NEWSPAPERS

Or Any volumes larger than 14", all are Adhesive bound. 4 3/4" maximum thickness. Material should come collated/stacked in order to avoid time charges. We do double check collation & press out folds when binding.

Tabloid (16"-18" in height):

Under 3" thick 80.00
 3" thick and over 95.00

Full size (Over 18" in height):

Under 3" thick 100.00
 3" thick and over 115.00

Newspaper Ads or inserts left in, add 21.50

Special Features

Offered at no extra charge-

- ♦ Trimming.
- ♦ Binding slips provided.
- ♦ Durable sewing on most bindings.
- ♦ We keep full record on journal bindings.
- ♦ Prompt, personalized service customized to *your* needs.

Special or Extra Operations:

Binding Options:

Ad Stripping (from front/back), per issue 50
 Ad Stripping (scattered), per issue 2.00
 Binding Slip Preparation 40
 Overthick 2 1/2" - 3" 3.00
 Overthick for each addl 1/2" over 3" 5.00
 Pockets provided / back cover 3.75
 Pocket removed from old binding, placed in new.. 3.25
 Surcharge per every inch over 12" 3.25
 (Items larger than 16" charged as newspapers)

Cover Options:

Rebinding in Old Cover (still together)..... 15.00
 Full Color Copy Cover - up to 12" 3.25
 Each additional color copy cover in a set 2.50
 Missing title set up (for color copy) 3.25
 Mount old paper back covers on new binding 2.75
 Mylar cover, using dust jacket, laminate only* NC
 (*Note: This is no longer available on paper back covers; we recommend the color copy option above instead. The Bindery may reject covers that are unworkable).

Printing Options:

Personalization/Imprint, spine or front cover 2.50
 Front Cover Title, per 7 lines of type..... 7.50
 Rulings (per single or double) 1.50
 Call Numbers (each)95

Miscellaneous:

Pickup or Delivery (Madison area)..... 20.00
 Out of town Pickup or Delivery (Wisconsin) 25.00
 ♦ Pickup or Delivery in WI free with orders of 100+ vols.
 ♦ Automated pickup request now available online 24/7 at:
<http://www.grimmbindery.com/contactus.html>
 Minimum pickup of 25 vols.

Excessive mending, sponging and pressing, stubbing or special work will be charged on a time basis.

Prices effective April 15, 2007.
 Subject to change without notice.

Phone: 608-221-4443
 Email: info@grimmbindery.com

**Magazine/Journal Binding
 Order Form**

Shipping & Contact Information

Name _____
 Address _____
 City/State/Zip _____
 Daytime phone _____ Email Address _____

Binding Information

Magazine/Journal Binding in Hardcover – Bound together in a hard cover with the title, volume and year printed on the spine in gold (months, page or issue numbers may also be added). Pages will be oversewn unless a better method is determined by the paper or margins. Cost for magazine/journals up to 8 1/2" x 11" is typically \$32.00 plus Shipping/Handling. Volumes over 2 1/2" thick will be charged \$3.00 for the first 1/2" over; and \$5.00 more for each additional 1/2" thereafter. In addition to binding we'll make a sample back so future issues sent will all be done with the same color and spine setup for a uniform set. We recommend Buckram for strength on heavier magazines & journals. **Please indicate the material and color desired here:** [Click here to make selection](#)

Additional Options:

- Remove advertisements from the issues to reduce the size. Cost is either \$2.50 per 6 issues if just at the front & back; or \$10.00 per 6 issues if scattered throughout.
 - Print Title on Front Cover in addition to the standard spine location. Additional \$7.50.
 - Personalize the bottom of the spine or lower right hand corner of the front cover with the following name: _____ Additional \$2.00 per area.
 - Add ruled lines at the top & bottom of the spine for decoration. Additional \$2.50 per book.
- Bind issues As bundled Yearly Every 6 months Every 4 months Quarterly

If you desire more choices such as larger or fancy fonts, different font colors, special tooling, artwork, 3/4 or full leather, please enclose a letter or call us to discuss your options. There are many available to choose from. Also, if you can imagine it, odds are we can bind it!

Additional Information Needed

Pages are normally trimmed 1/8" to clean edges, do you want yours trimmed? Yes No
 I've enclosed a check for the down payment of \$30.00 required to start work Yes No
 Please charge my credit card for the \$30.00 down payment to start work Yes No
 Credit Card # _____ - _____ - _____ - _____ Exp. Date _____
 Signature: _____

Submit Form

Shipping & handling extra. Upon receipt of your order, we'll contact you with a full estimate