

Block 7 Parking Structure



Zoning, Neighborhoods and
Development Committee Meeting
May 17, 2016



Site Location



- A. BMO HARRIS BRADLEY CENTER
- B. UW MILWAUKEE PANTHER ARENA
- C. PARKING GARAGE
- D. MILWAUKEE THEATER
- E. MILWAUKEE AREA TECHNICAL COLLEGE
- F. POLICE ADMINISTRATION BUILDING
- G. TRINITY LUTHERAN CHURCH
- H. ZILBER PARK/UWM SCHOOL OF PUBLIC HEALTH
- I. BOYS & GIRLS CLUB OF GREATER MILWAUKEE
- J. HAYMARKET SQUARE PARK
- K. DR. MARTIN LUTHER KING DR. / OLD WORLD THIRD ST.
- L. PERE MARQUETTE PARK
- M. TURNER HALL

Site Location

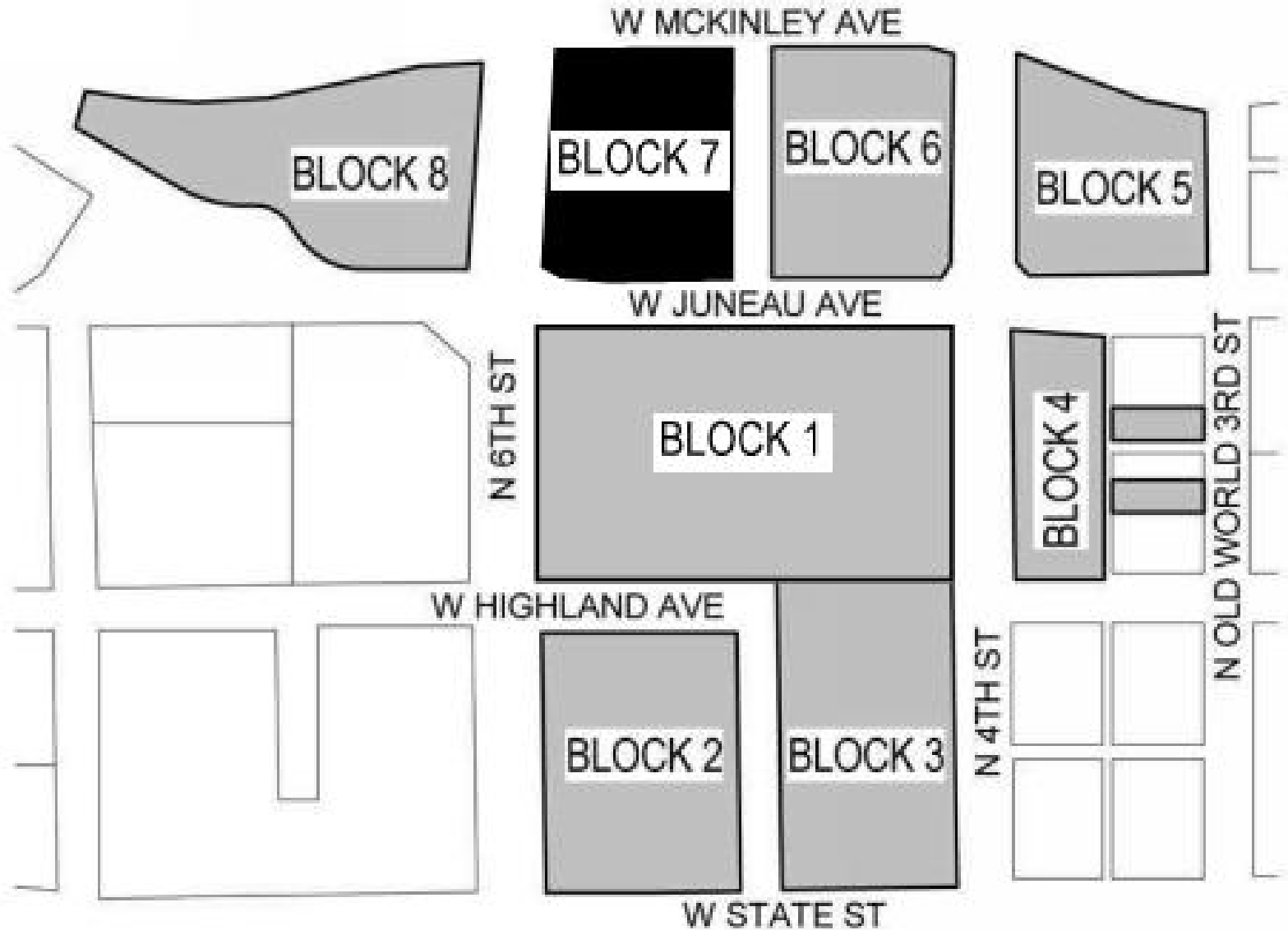

Site Plan



Landscape Plan

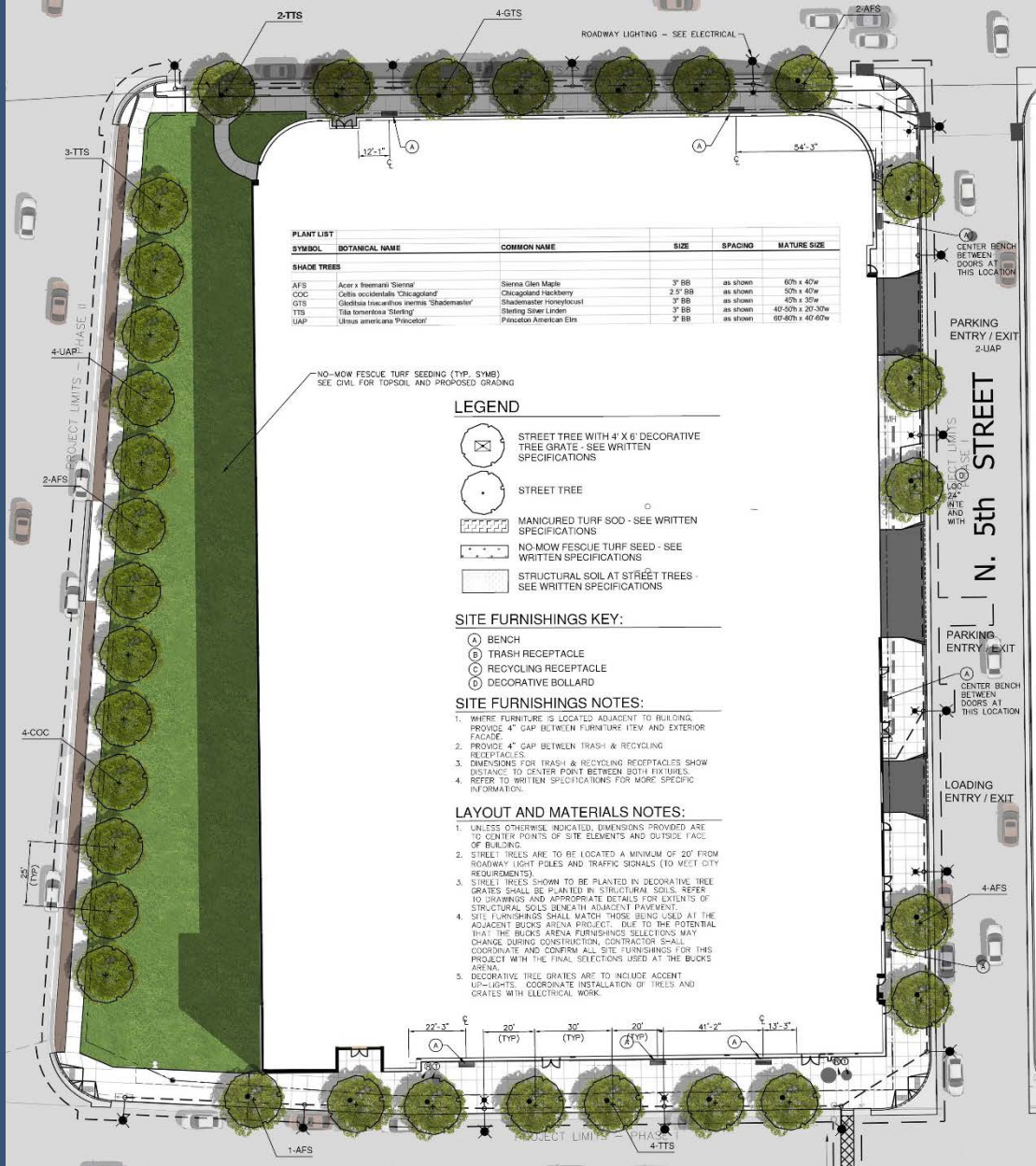

Ground Floor



Second Floor

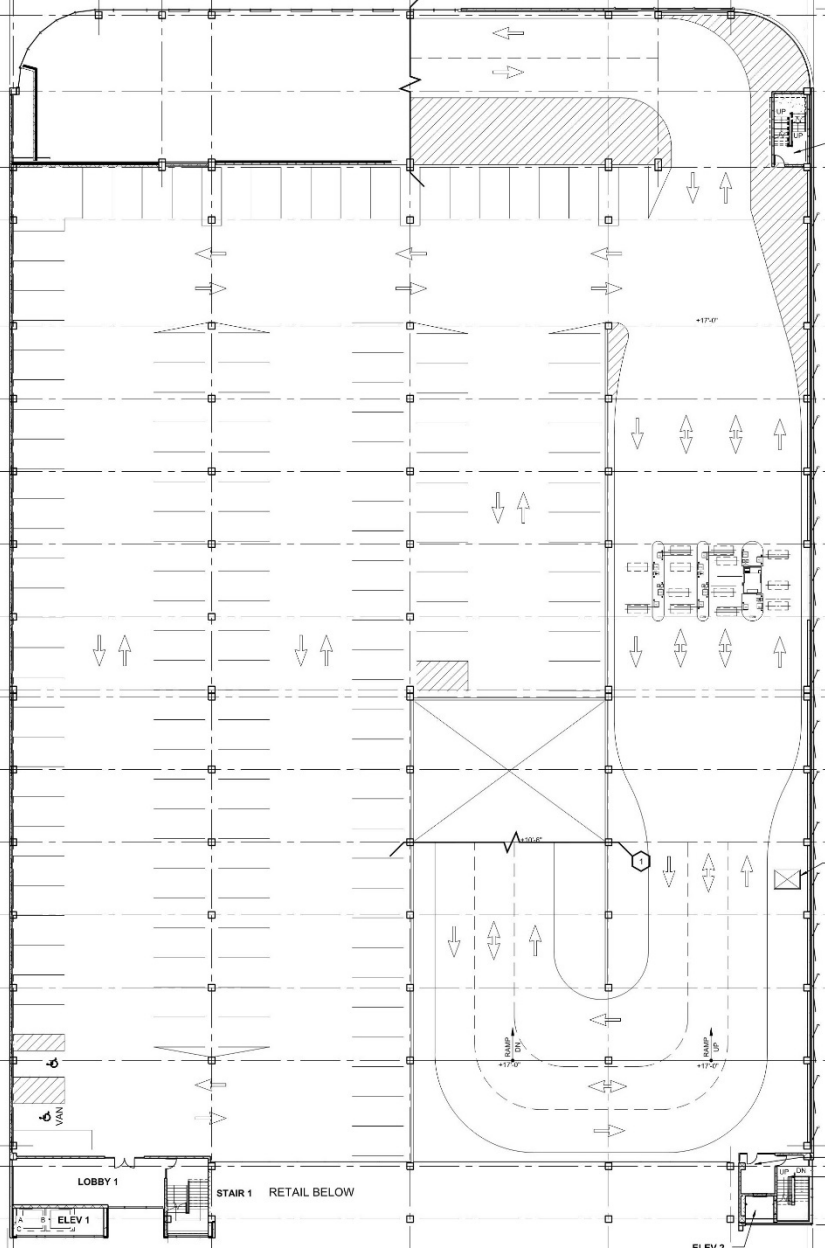

Third Floor

(Fourth, Fifth and Sixth are Similar)

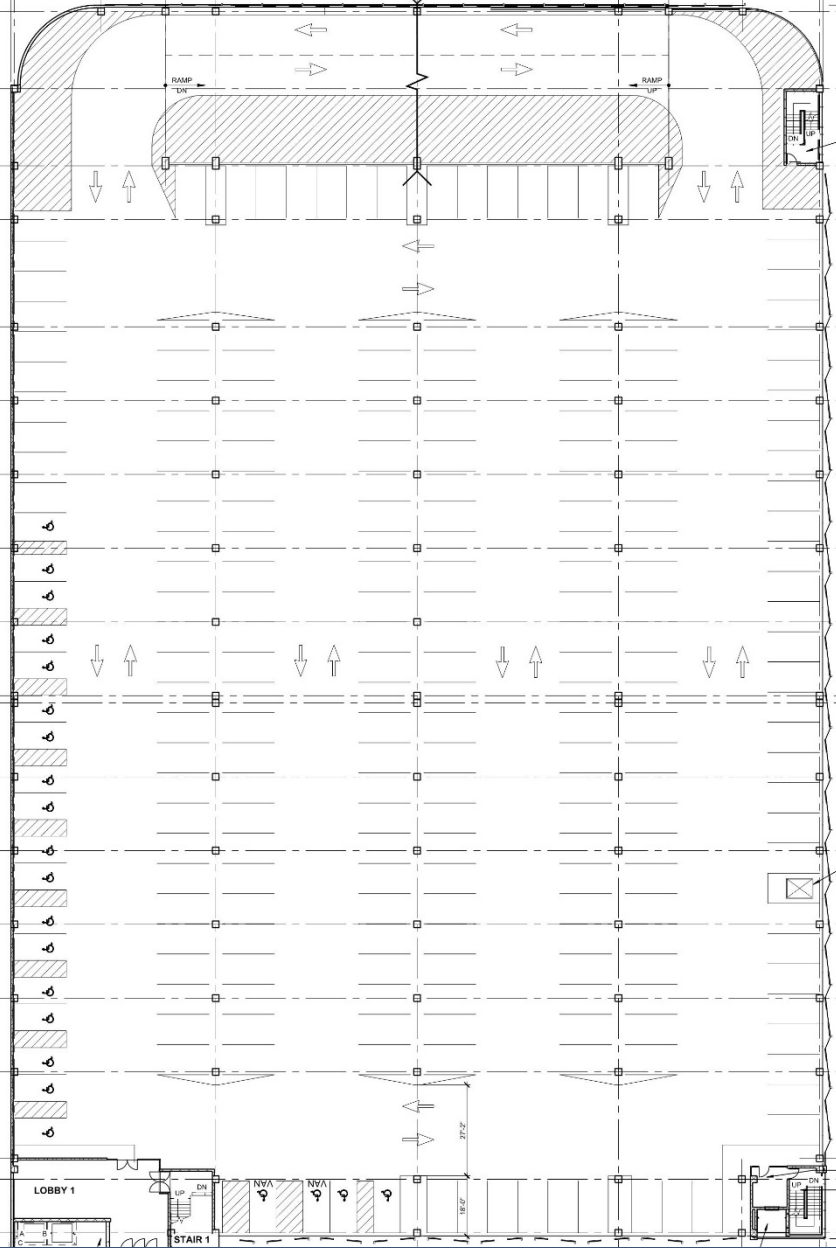

6th and McKinley Perspective

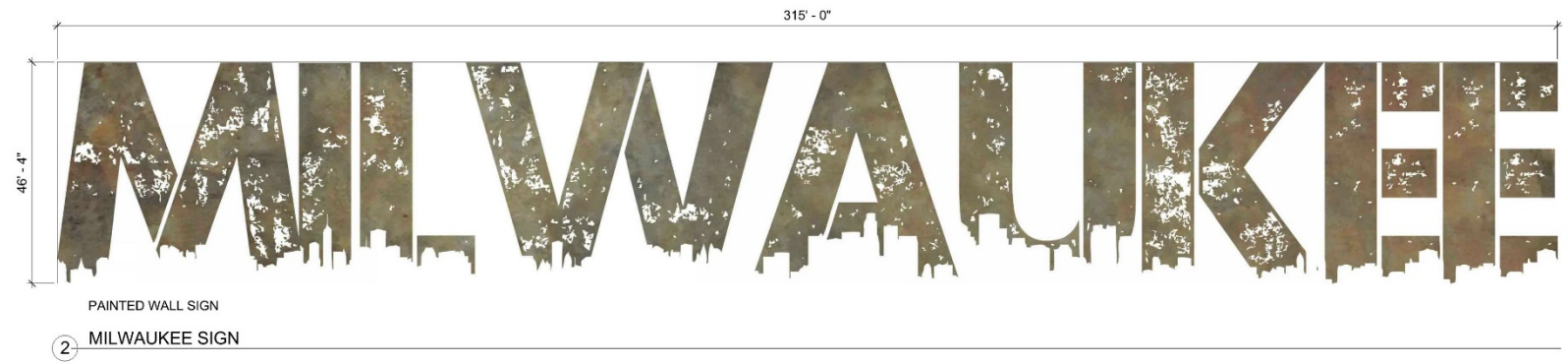

North Elevation

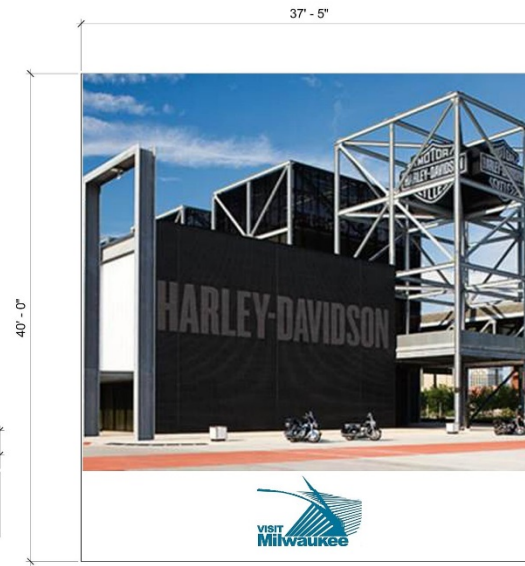
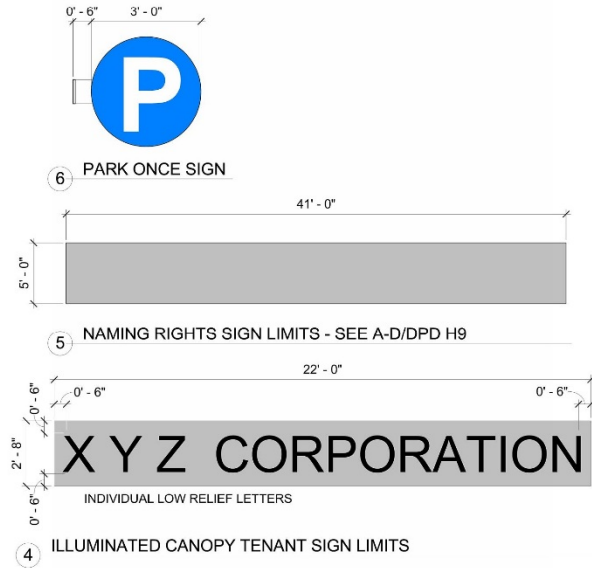

③ DIGITAL DISPLAY BOARD - ELEVATION

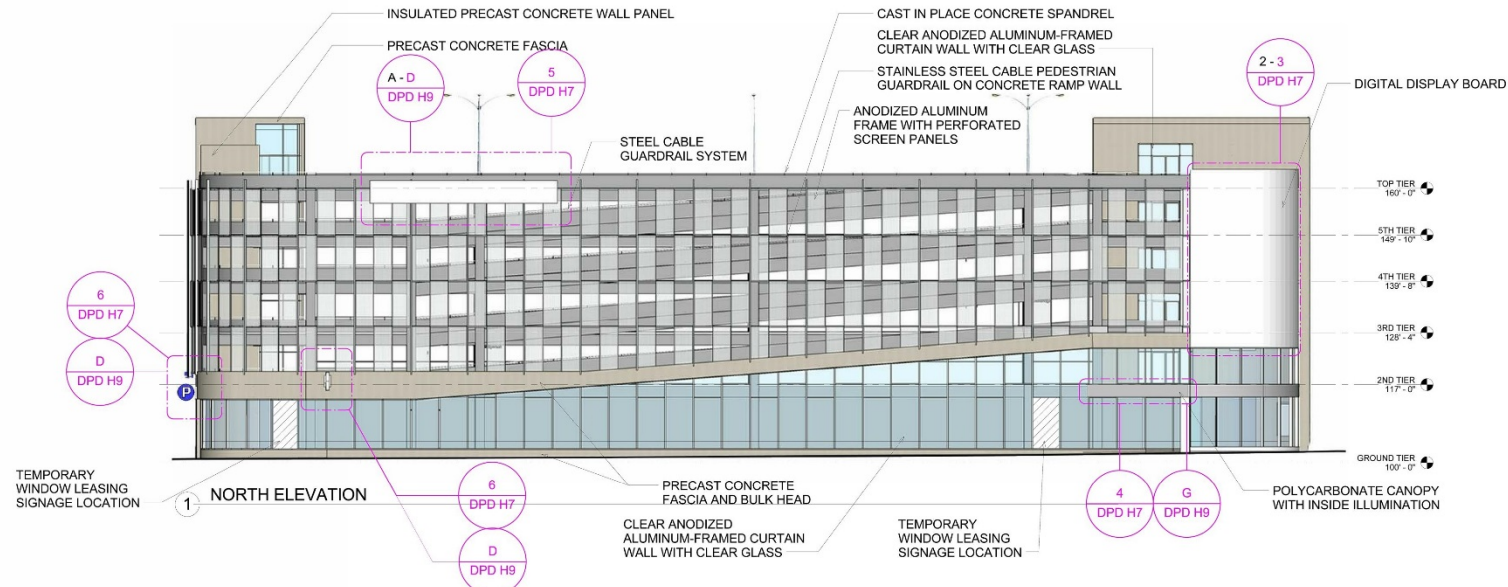
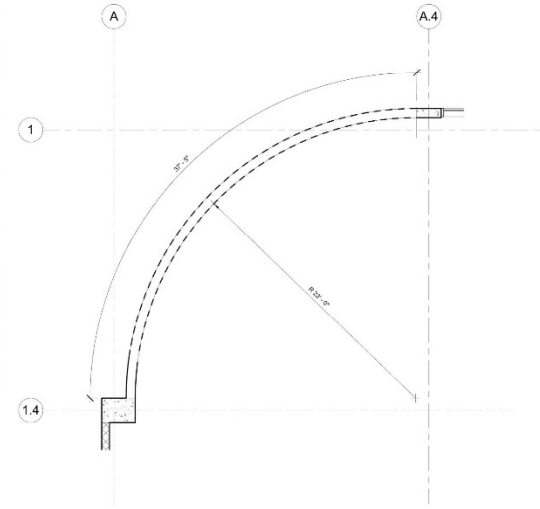

North Elevation

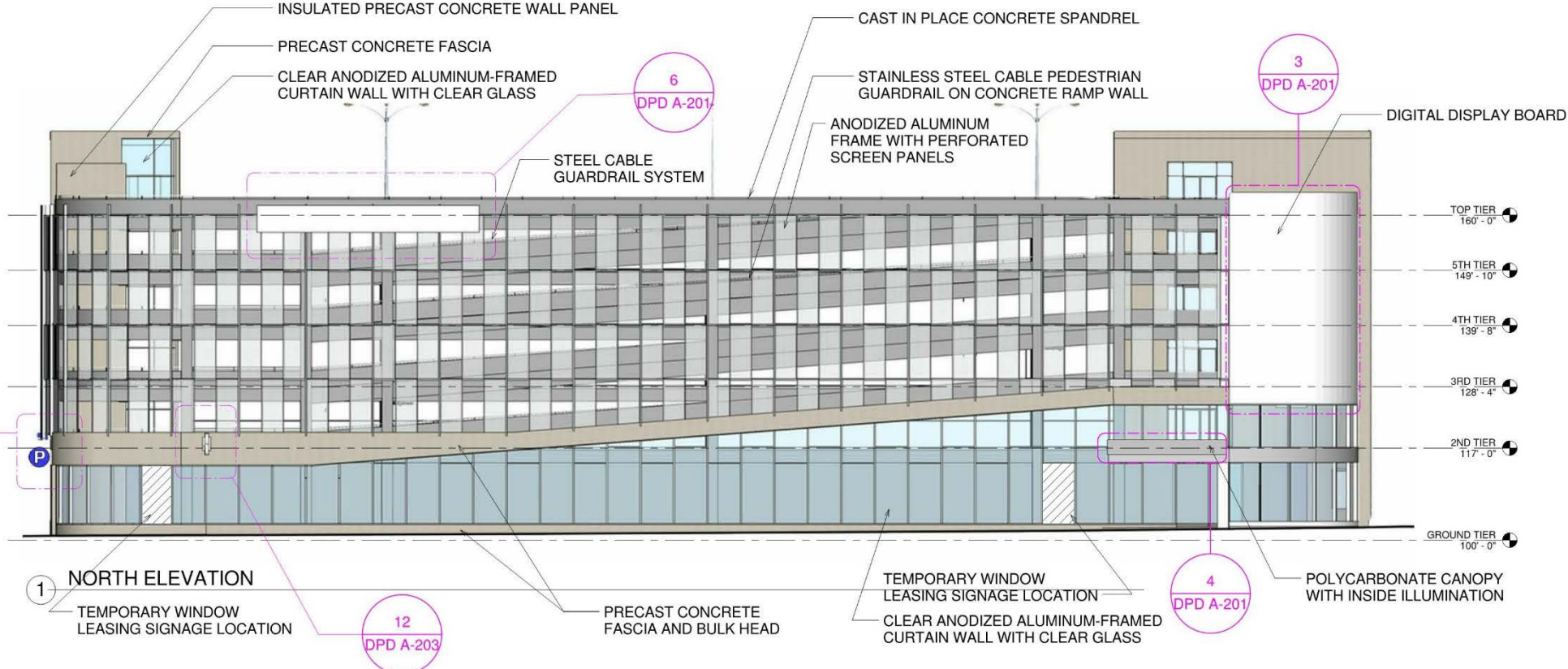

East Elevation

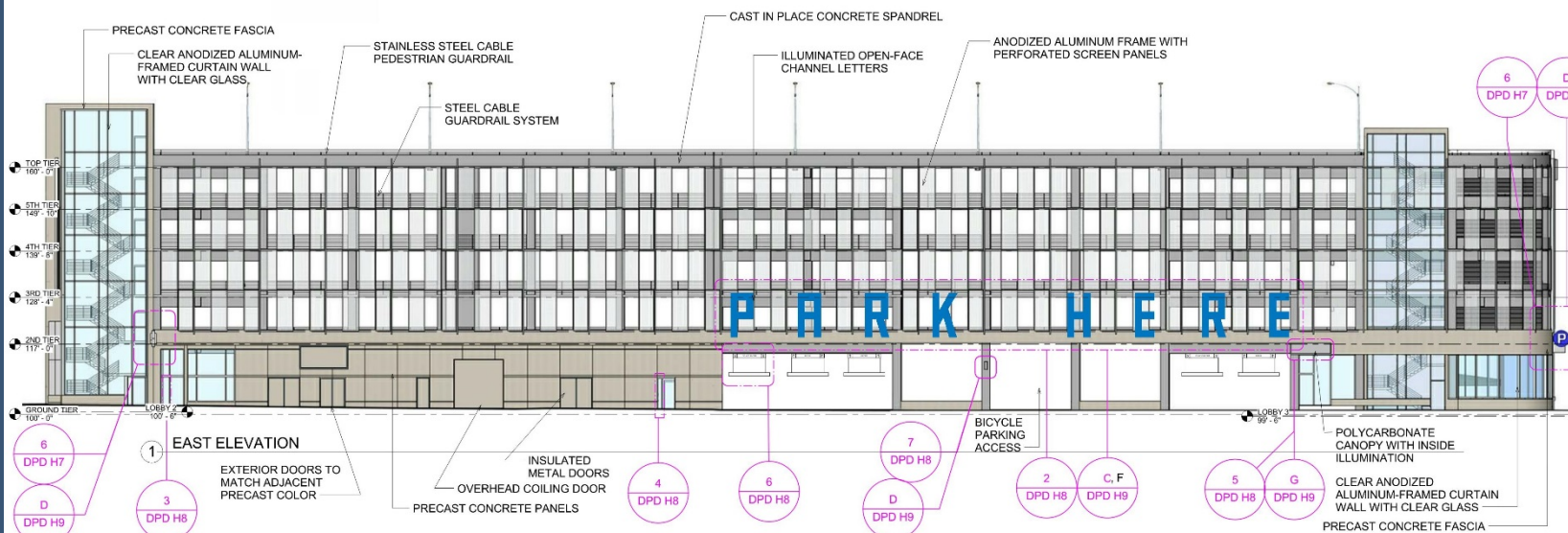
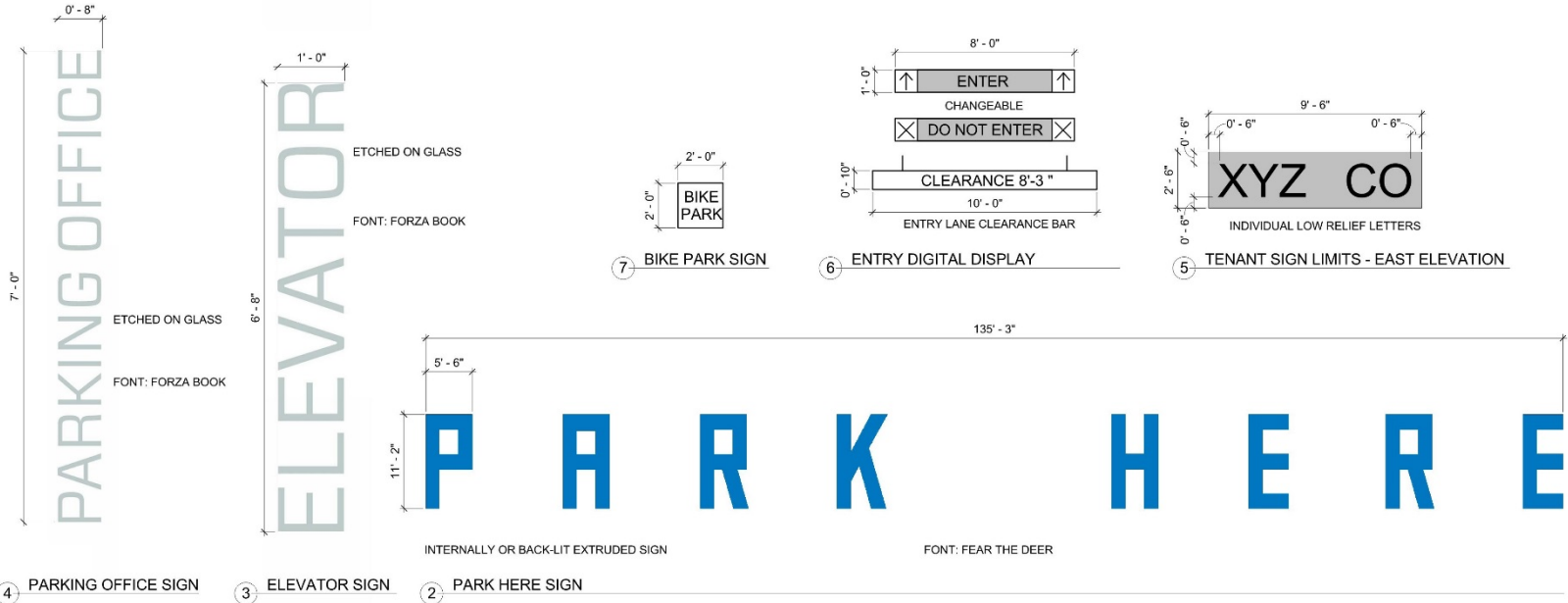

Metal Panel Assembly

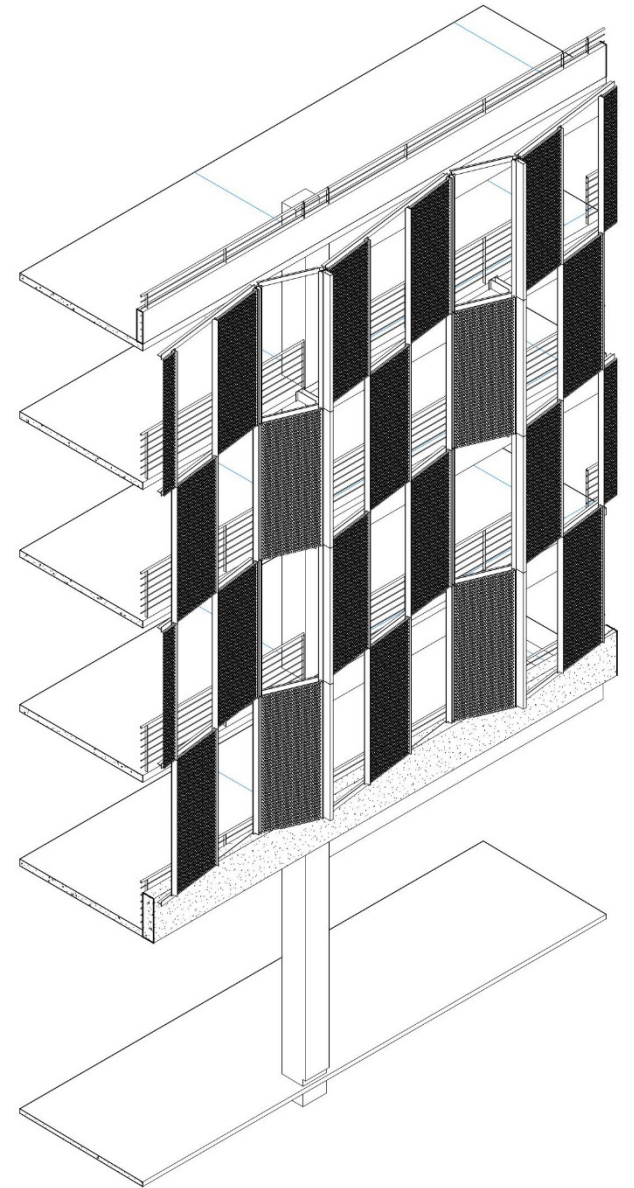
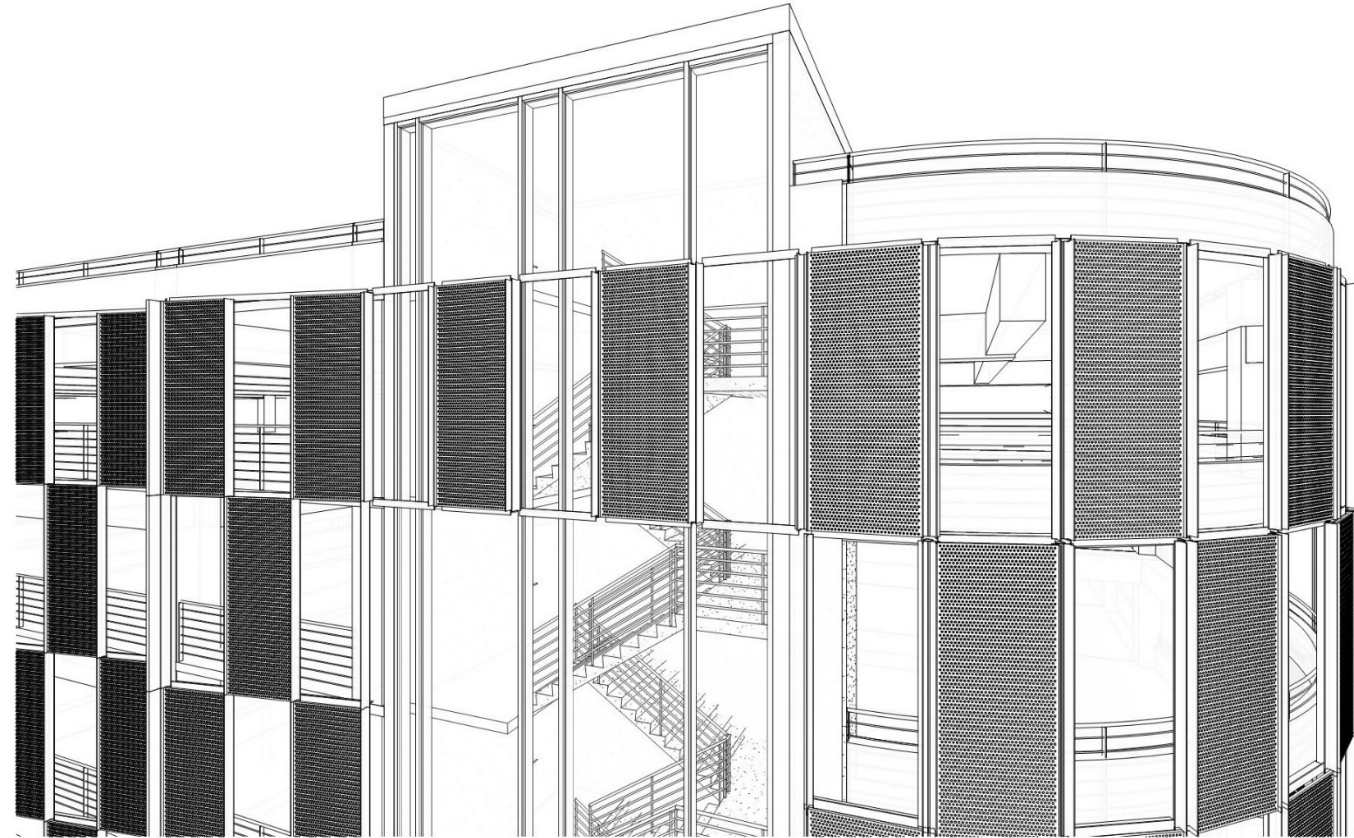

Metal Panel Assembly

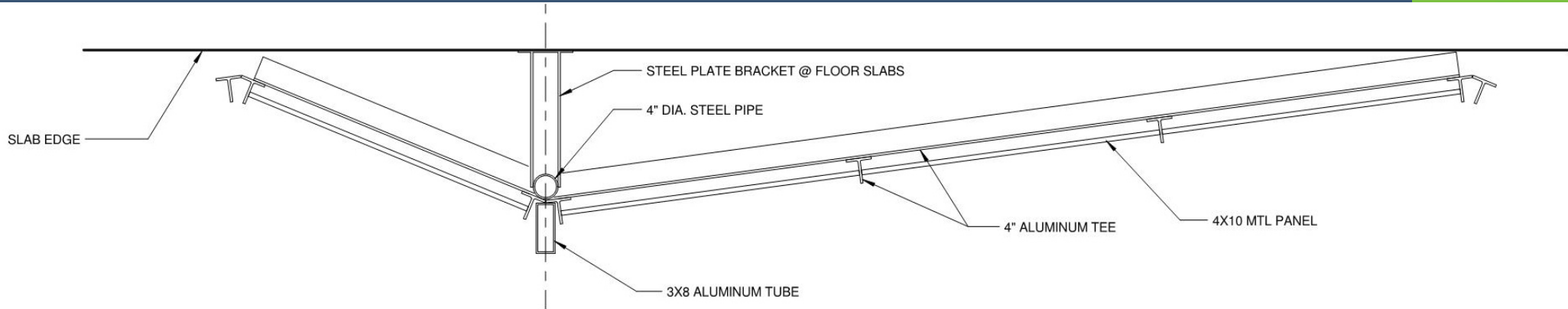
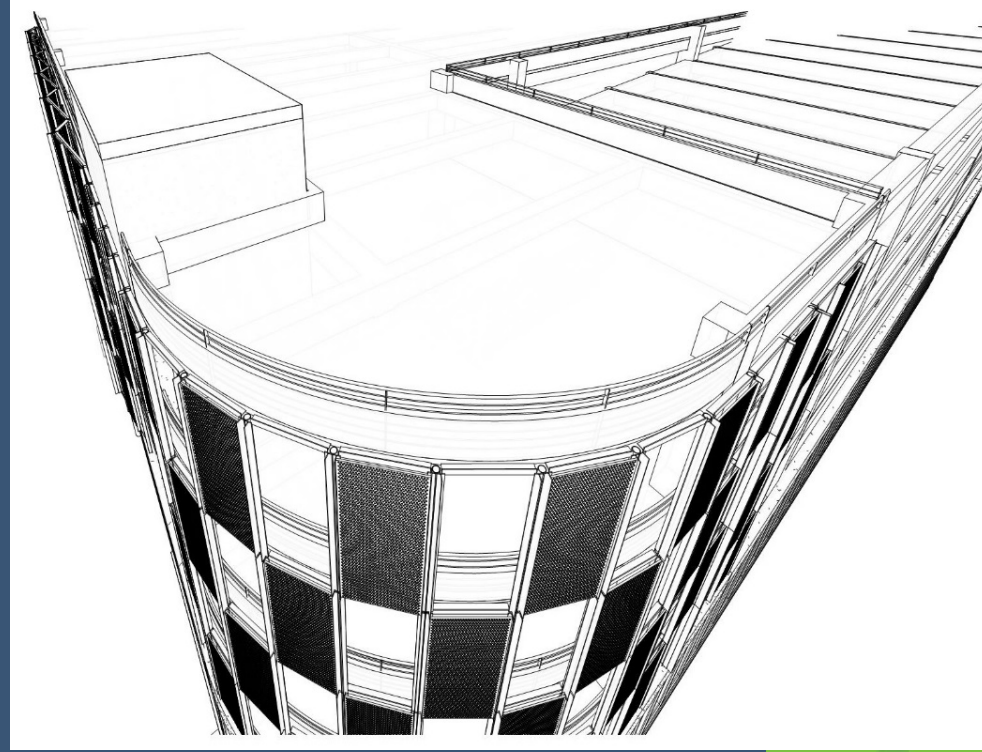
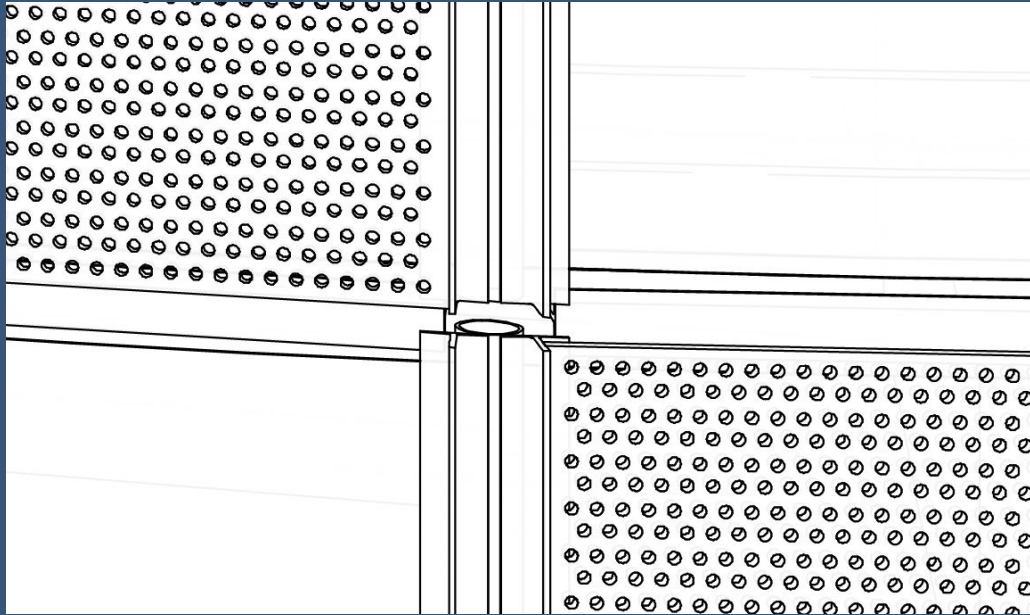

South Elevation



H BLADE SIGN - TYPE



G ILLUMINATED CANOPY SIGN - TYPE



F FRONT LIT - TYPE



E STENCIL SIGN - TYPE



D PUSH THRU SIGN - TYPE



C OPEN FACE SIGN - TYPE



B REVERSE LIT SIGN - TYPE



A FRONT/BACK LIT SIGN - TYPE

DETAILS WITH LETTER DESIGNATIONS ARE FOR SIGNAGE STYLE TYPES - FOR REFERENCE/EXAMPLE ONLY
SEE DETAILS WITH NUMERICAL DESIGNATIONS FOR MORE SPECIFIC PARAMETERS FOR INDIVIDUAL LOCATIONS

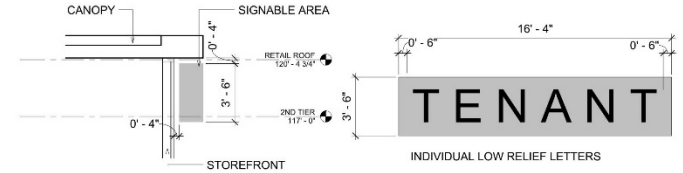

3 SOUTH CANOPY SECTION

2 TENANT SIGN LIMITS - SOUTH ELEVATION

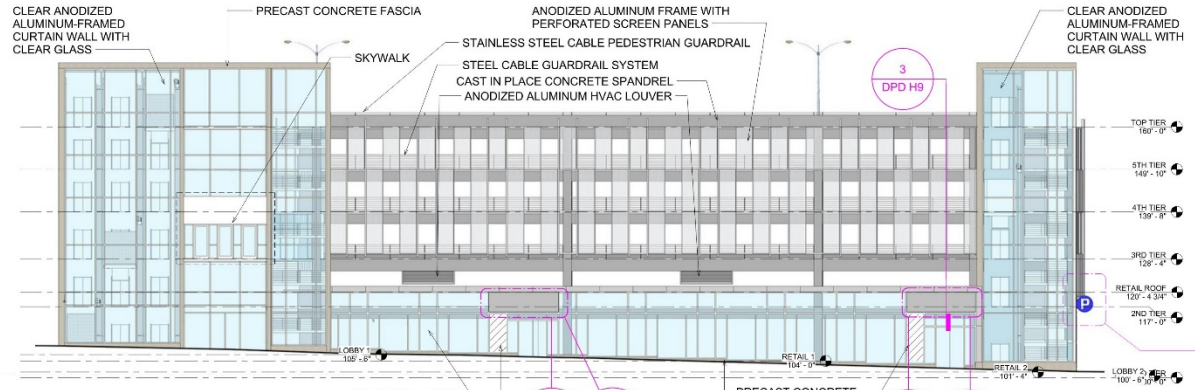

1 SOUTH ELEVATION

ALUMINUM-FRAMED STOREFRONT
TEMPORARY WINDOW LEASING SIGNAGE LOCATION

2 DPD H9 A-D DPD H9

TEMPORARY WINDOW LEASING SIGNAGE LOCATION

2 DPD H9 A-D DPD H9

6 DPD H7

South Elevation

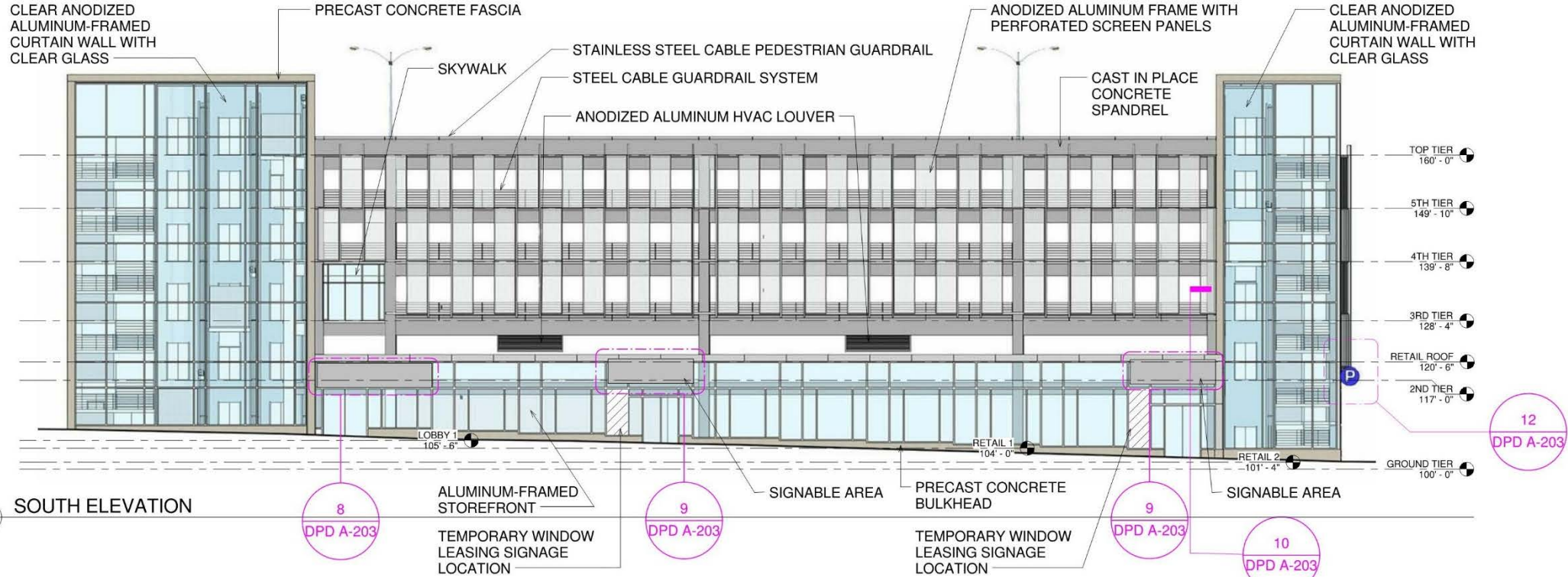

6th and McKinley



5th and McKinley



5th and Juneau



Future Housing Plan & Elevation

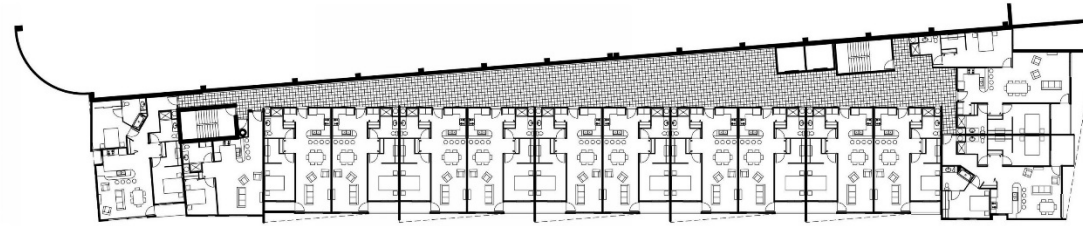

8 HOUSING FLOOR PLAN - TYPICAL UPPER LEVEL

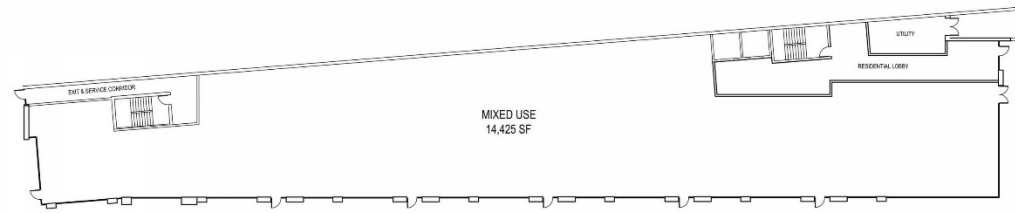

7 HOUSING FLOOR PLAN - GROUND LEVEL

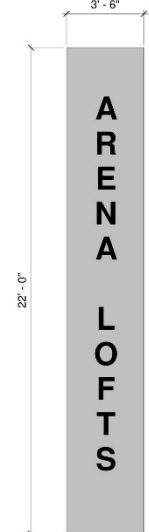

6 RESIDENTIAL SIGN SEE 2-7/DPD A-203



5 WEST ELEVATION WITH HOUSING (DPD)



4 SOUTH ELEVATION OF HOUSING (DPD)



3 NORTH ELEVATION OF HOUSING



2 COMMERCIAL SIGN - NORTH AND SOUTH SEE 2-5/DPD A-203

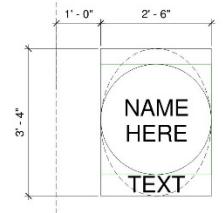

1 COMMERCIAL BLADE SIGN - WEST FACADE

Future Housing Elevations

2
DPD A-204

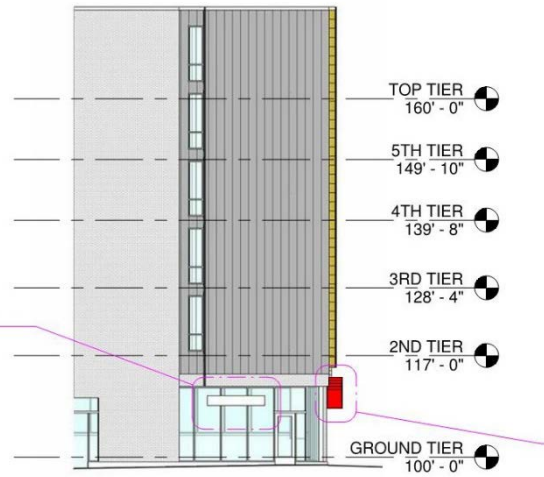

3 NORTH ELEVATION OF HOUSING

2
DPD A-204



4 SOUTH ELEVATION OF HOUSING (DPD)

3
DPD A-201



6
DPD A-204

5 WEST ELEVATION WITH HOUSING (DPD)

1
DPD A-204

6th and McKinley w/ Future Housing



6th and Juneau w/ Future Housing

