



Certificate of Appropriateness

Milwaukee Historic Preservation Commission/841 N Broadway/Milwaukee, WI 53202/phone 414-286-5722

Property Description of work

2728 W. Burnham St., American System Built Homes Historic District

Installation of a temporary wooden step to the entrance on the west elevation of the house. Step will be constructed using 2x6 boards as a base with 1x6 deck boards.

Date issued 7/26/2023

In accordance with the provisions of Section 320-21 (11) and (12) of the Milwaukee Code of Ordinances, the Milwaukee Historic Preservation Commission has issued a certificate of appropriateness for the work listed above. The work was found to be consistent with preservation guidelines. The following conditions apply to this certificate of appropriateness:

Installation of the step is a temporary measure not to exceed 12 months.

All work must be done in a craftsman-like manner, and must be completed within one year of the date this certificate was issued. Staff must approve any changes or additions to this certificate before work begins. Work that is not completed in accordance with this certificate may be subject to correction orders or citations. If you require technical assistance, please contact Historic Preservation staff as follows: Phone: (414) 286-5722 E-mail: hpc@milwaukee.gov.

If permits are required, you are responsible for obtaining them from the Milwaukee Development Center. If you have questions about permit requirements, please consult the Development Center's web site, www.milwaukee.gov/lms, or call (414) 286-8210.

City of Milwaukee Historic Preservation

Copies to: Development Center, Ald. Zamarippa



Location of temporary step

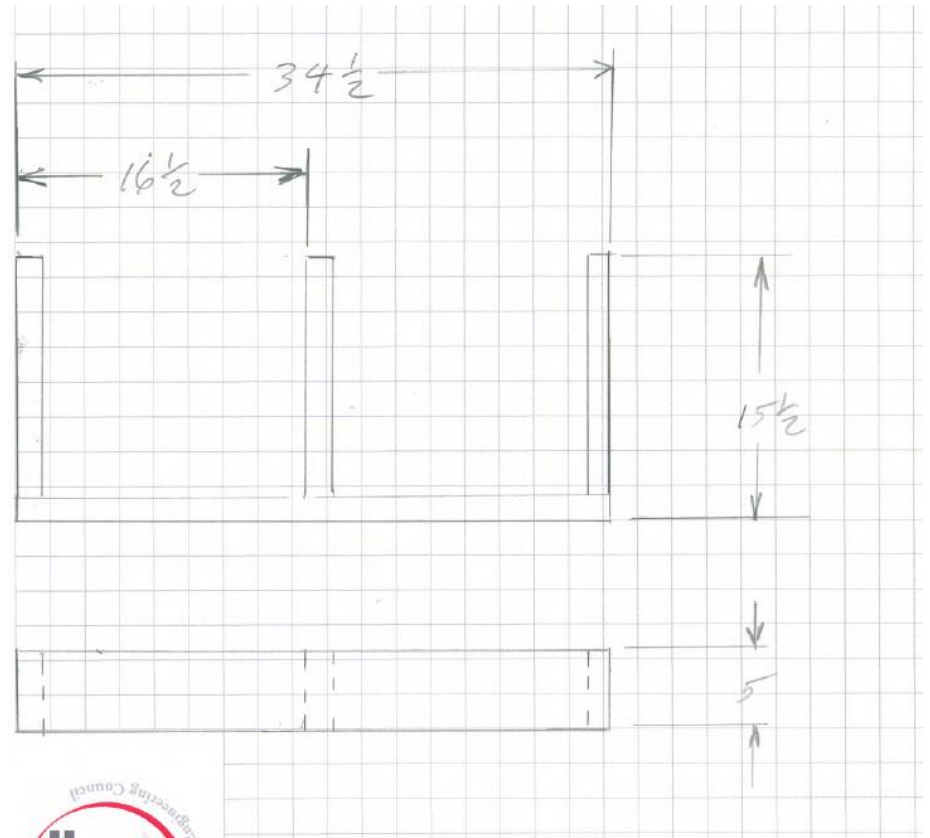
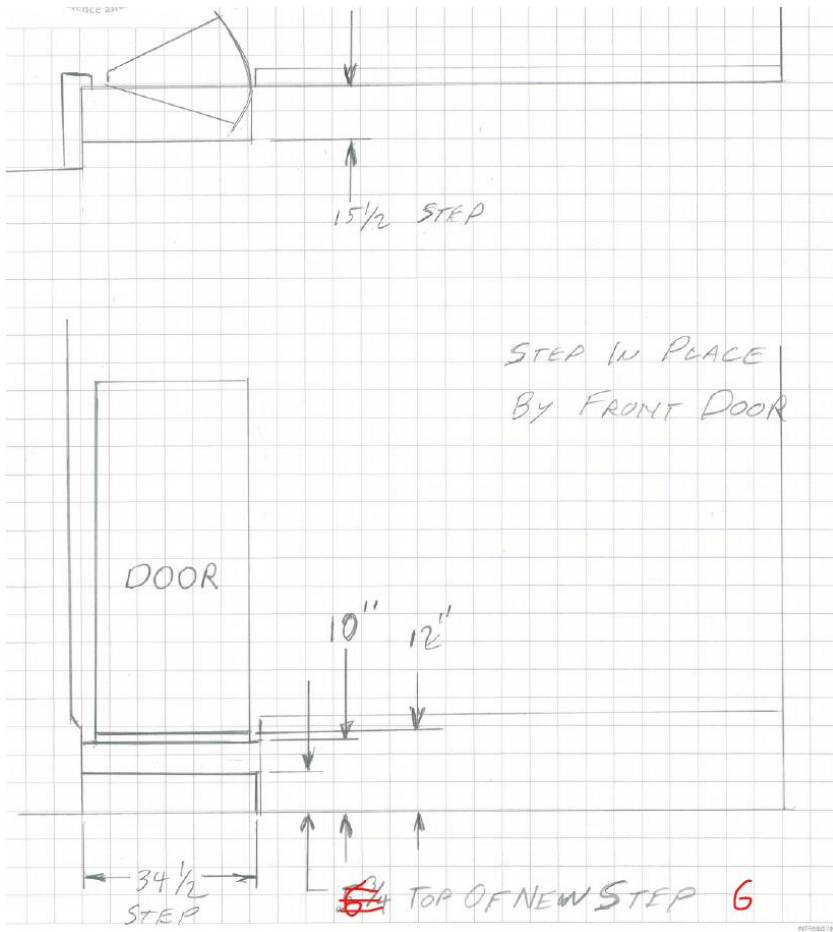

Temporary step specs