



Certificate of Appropriateness

Milwaukee Historic Preservation Commission/200 E. Wells Street/Milwaukee, WI 53202/phone 414-286-5712/fax 414-286-3004

Property 2015 N. PALMER ST.

Description of work Replace all three front second story windows and one second floor rear window. All windows shall be all wood with true divided light and coved muntins in a in two-over-two configuration. Front windows shall fit the existing opening and match the arch per attached drawing with arched glass in the top sashes. Glazing in rear window may be rectangular and not does not need to conform to the segmental arch of the window opening.

Date issued 9/12/2017 PTS ID 114358 COA: replace 2nd floor front windows

In accordance with the provisions of Section 320-21 (11) and (12) of the Milwaukee Code of Ordinances, the Milwaukee Historic Preservation Commission has issued a certificate of appropriateness for the work listed above. The work was found to be consistent with preservation guidelines. The following conditions apply to this certificate of appropriateness:

1. Any new storms/screens to be all wood.
2. Any Low-E glazing must be clear and untinted.

All work must be done in a craftsman-like manner, and must be completed within one year of the date this certificate was issued. Staff must approve any changes or additions to this certificate before work begins. Work that is not completed in accordance with this certificate may be subject to correction orders or citations. If you require technical assistance, please contact the Historic Preservation staff as follows: Phone: (414) 286-5712 E-mail: HPC@milwaukee.gov.

If permits are required, you are responsible for obtaining them from the Milwaukee Development Center. If you have questions about permit requirements, please consult the Development Center's web site, www.milwaukee.gov/build, or call (414) 286-8210.

Tom Adams

City of Milwaukee Historic Preservation Staff

Copies to: Development Center, Ald. Milele Coggs, Contractor, Inspector Paul Wolfgramm (286-2590)



Front view showing window to be replaced at left.

Exact design for front windows. Rear window shall be the same style with the same sash member thicknesses, but with dimensions adjusted as needed and arch-topped glass optional.

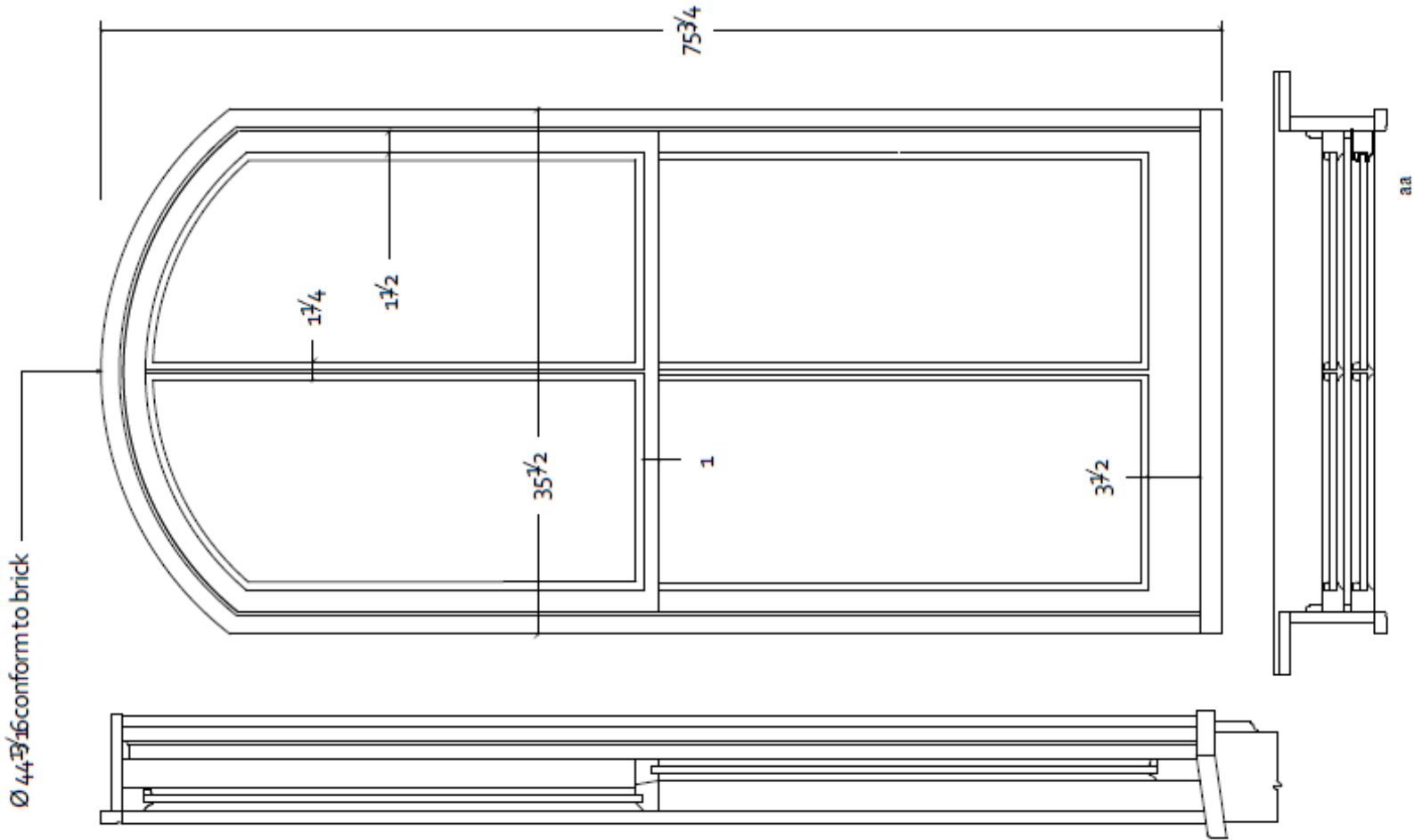
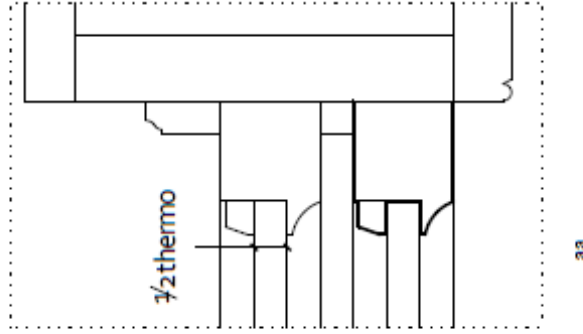

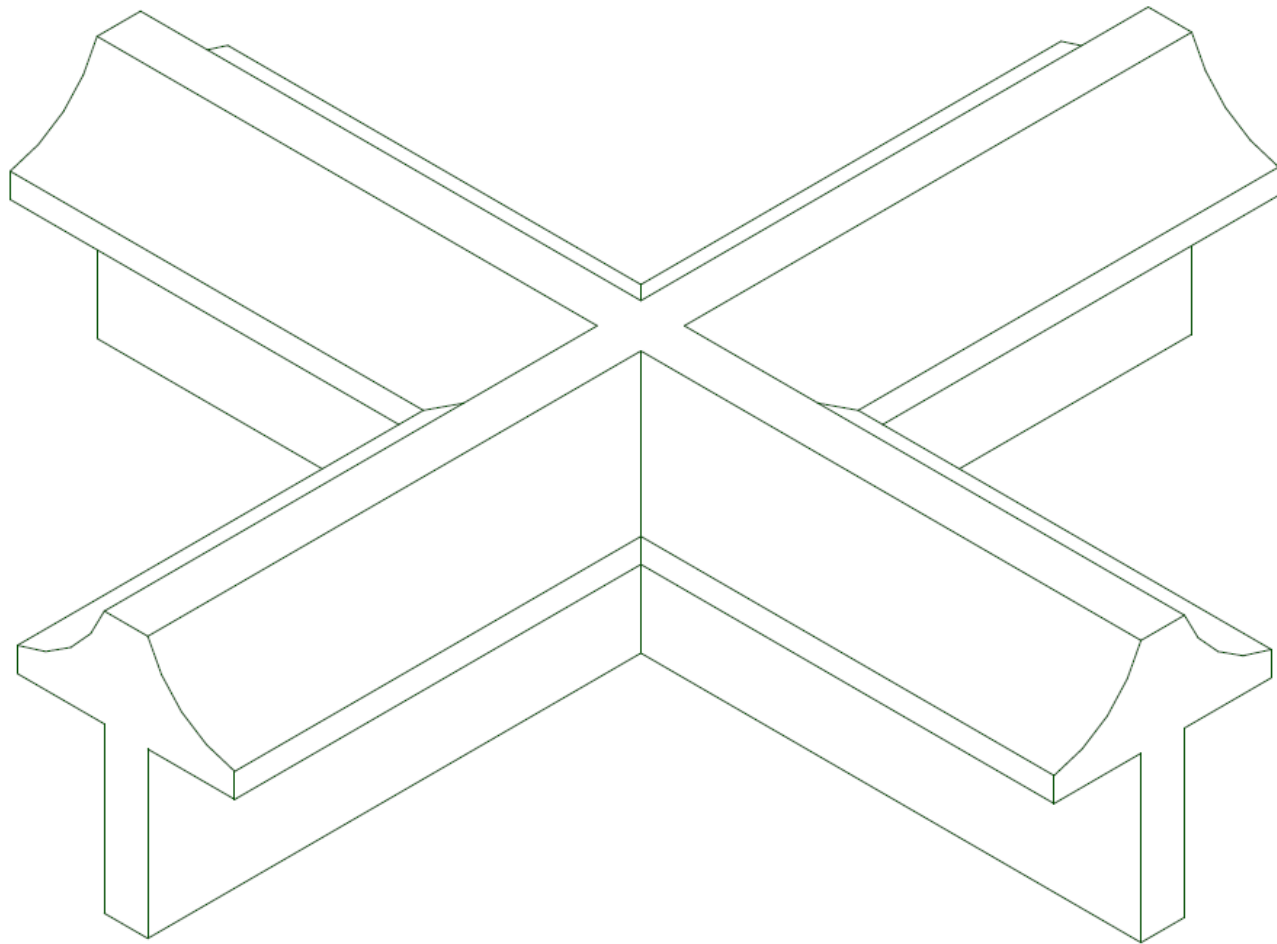

Muntin detail.

Rear window to be replaced.

1988



2017

