



CERTIFICATE OF APPROPRIATENESS APPLICATION FORM

Incomplete applications will not be processed for Commission review.
Please print legibly.

1. HISTORIC NAME OF PROPERTY OR HISTORIC DISTRICT: (if known)

ADDRESS OF PROPERTY:

2. NAME AND ADDRESS OF OWNER:

Name(s):

Address:

City:

State:

ZIP:

Email:

Telephone number (area code & number) Daytime:

Evening:

3. APPLICANT, AGENT OR CONTRACTOR: (if different from owner)

Name(s):

Address:

City:

State:

ZIP Code:

Email:

Telephone number (area code & number) Daytime:

Evening:

4. ATTACHMENTS: (Because projects can vary in size and scope, please call the HPC Office at 414-286-5712 for submittal requirements)

A. REQUIRED FOR MAJOR PROJECTS:

Photographs of affected areas & all sides of the building (annotated photos recommended)

Sketches and Elevation Drawings (1 full size and 1 reduced to 11" x 17" or 8 1/2" x 11")

Material and Design Specifications (see next page)

B. NEW CONSTRUCTION ALSO REQUIRES:

Floor Plans (1 full size and 1 reduced to a maximum of 11" x 17")

Site Plan showing location of project and adjoining structures and fences

PLEASE NOTE: YOUR APPLICATION CANNOT BE PROCESSED UNLESS BOTH PAGES OF THIS FORM ARE PROPERLY COMPLETED AND SIGNED.

5. DESCRIPTION OF PROJECT:

V^||Á•Á @eÁ[~ Á æ oÁ Á[EÖ^•&æ^Á|Á!][•^áÁ [\ Á &` áá * Á æ\áæ# Eá^•á } EÁ
æ ááá ^)•á }•Eááá } aÁ æ^Á æ Á^Áææ@áE

6. SIGNATURE OF APPLICANT:

Signature

Print or type name

Date

This form and all supporting documentation **MUST** arrive by 12:00 noon on the deadline date established to be considered at the next Historic Preservation Commission Meeting. Any information not provided to staff in advance of the meeting will not be considered by the Commission during their deliberation. Please call if you have any questions and staff will assist you.

Hand Deliver or Mail Form to:
Historic Preservation Commission
City Clerk's Office
200 E. Wells St. Room B-4
Milwaukee, WI 53202

PHONE: (414) 286-5722

hpc@milwaukee.gov

www.milwaukee.gov/hpc

Or click the **SUBMIT** button to automatically email this form for submission.

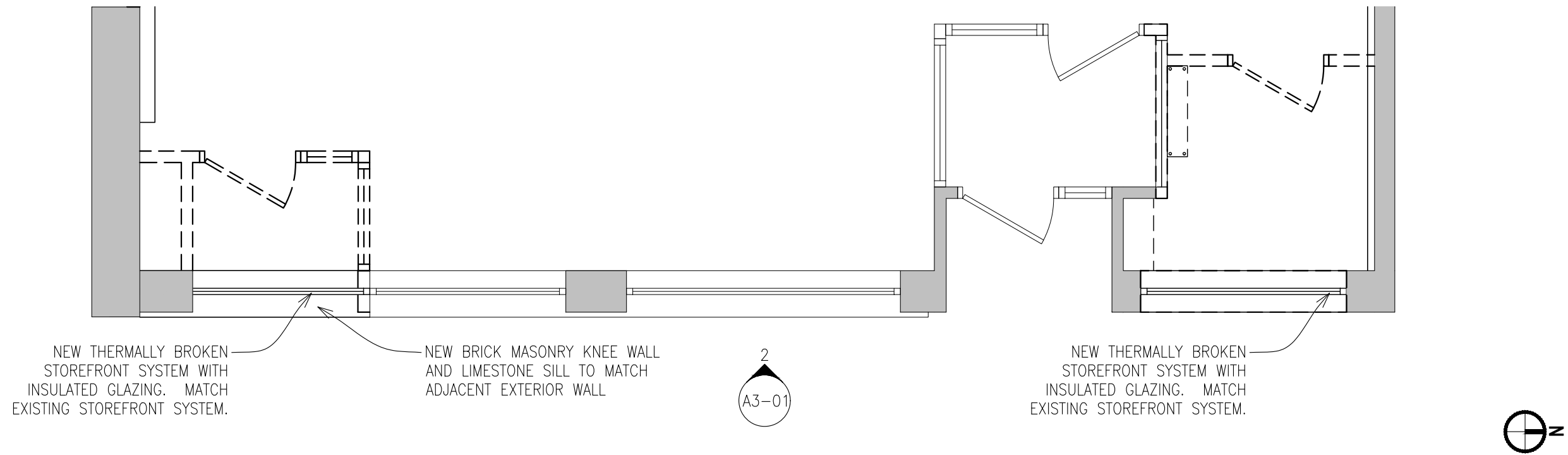

2 FLOOR PLAN
1/4" = 1'-0"

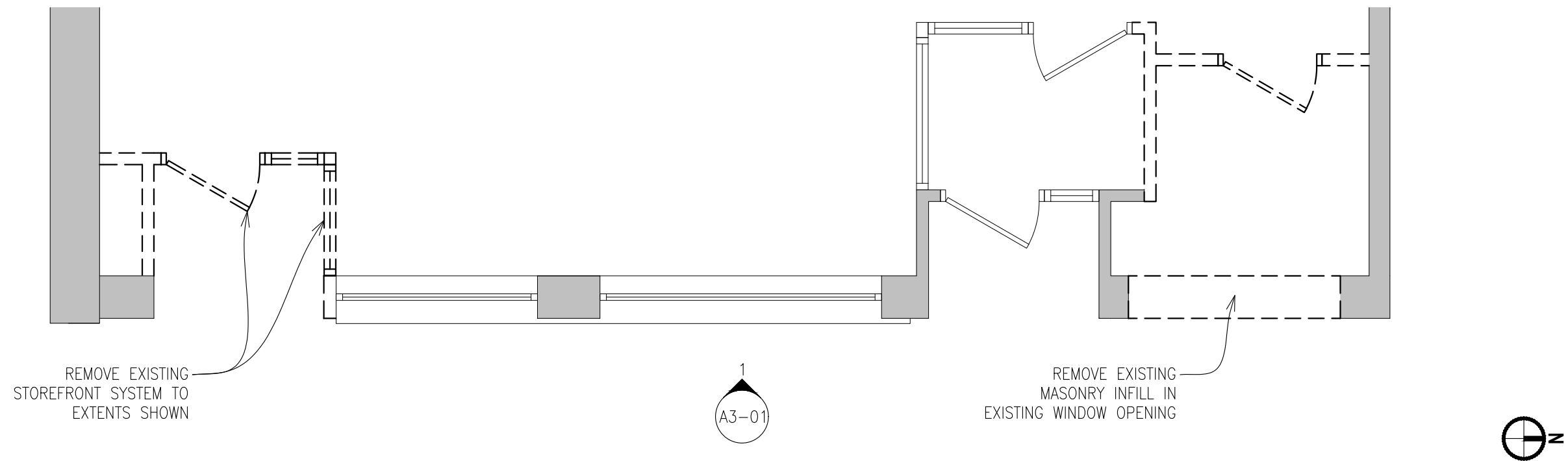

1 DEMOLITION FLOOR PLAN
1/4" = 1'-0"

FLOOR PLANS - A1-01

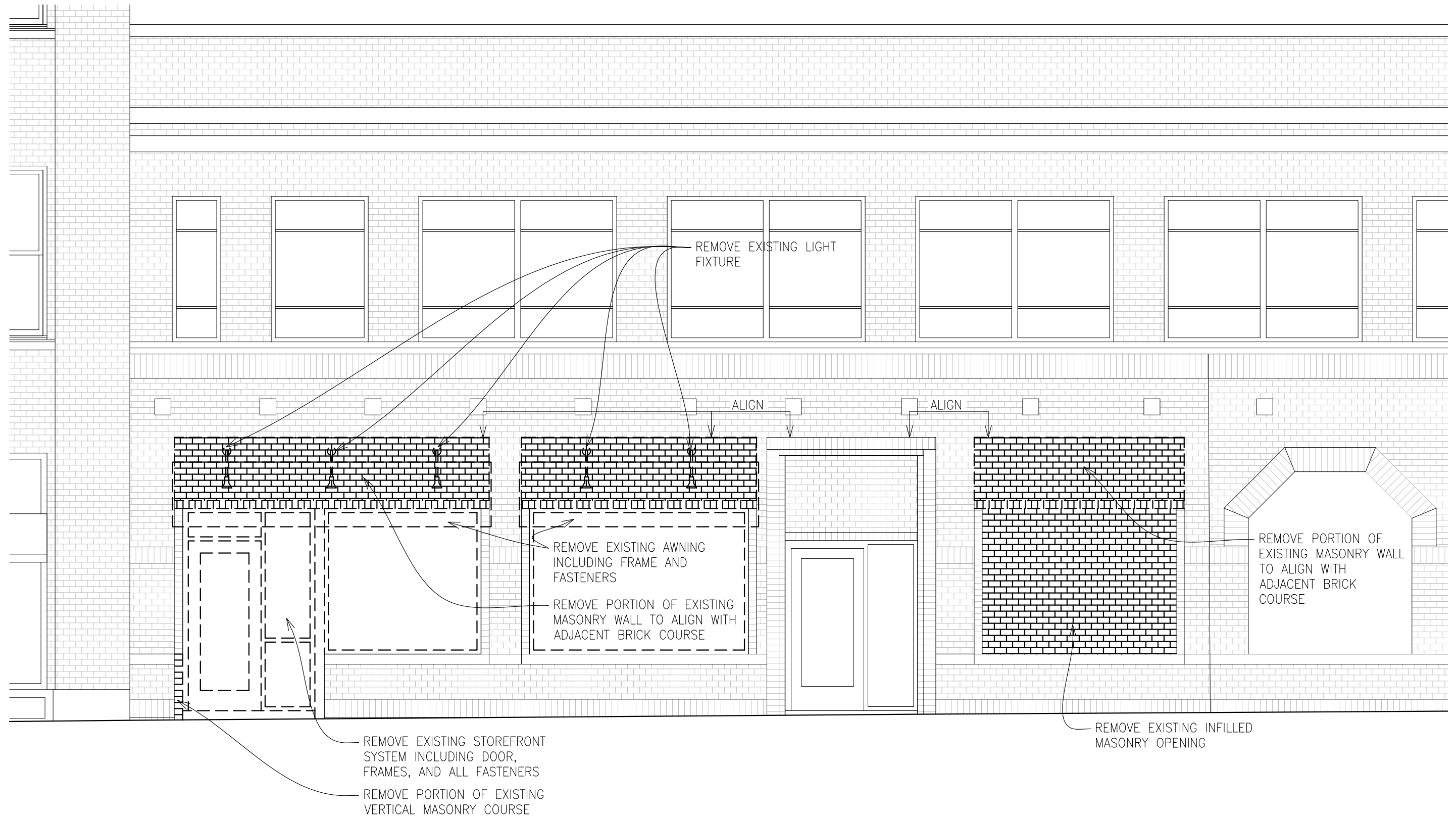

1 DEMOLITION EXTERIOR ELEVATION
1/4" = 1'-0"

EXTERIOR DEMOLITION ELEVATION - A3-01



NEW LIMESTONE SILL TO MATCH EXISTING
 NEW MASONRY KNEE WALL TO MATCH ADJACENT KNEE WALL. TOOTH IN BRICKS TO EXISTING WALL ON BOTH

NEW THERMALLY BROKEN STOREFRONT SYSTEM WITH INSULATED GLAZING. SYSTEM AND GLAZING TO MATCH EXISTING ADJACENT WINDOWS IN TENANT SPACE

NEW THERMALLY BROKEN STOREFRONT SYSTEM WITH INSULATED GLAZING. SYSTEM AND GLAZING TO MATCH EXISTING ADJACENT WINDOWS IN TENANT SPACE

1 EXTERIOR ELEVATION
 1/4" = 1'-0"

EXTERIOR ELEVATION - A3-01

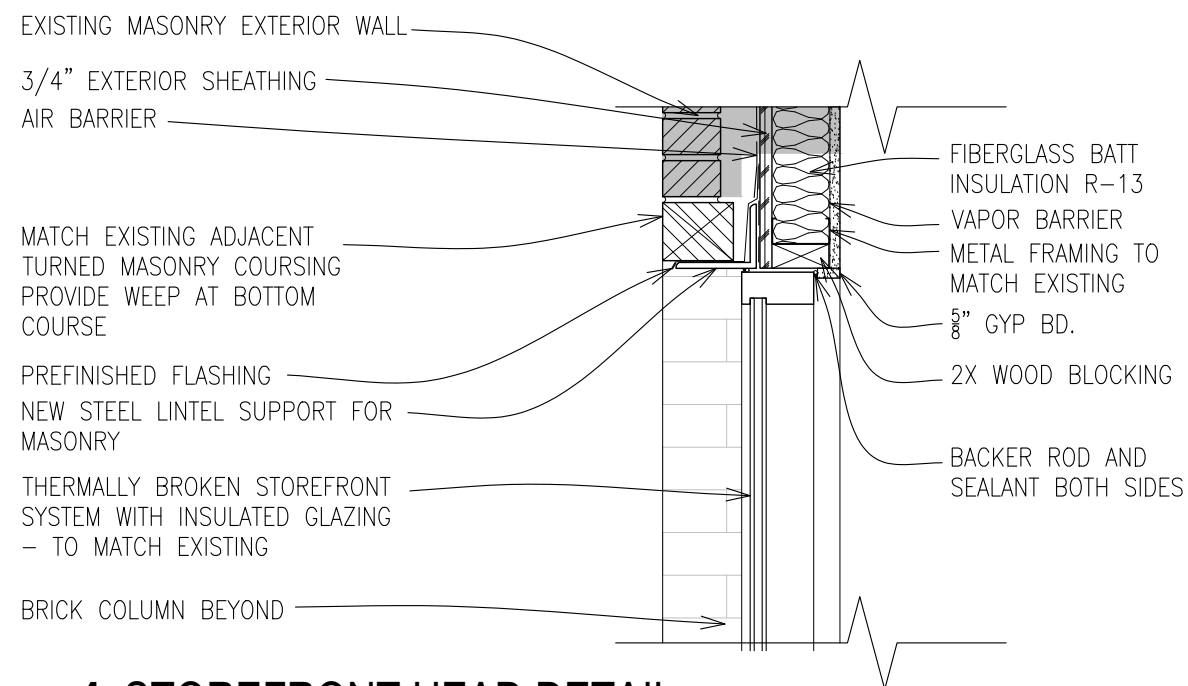

4 STOREFRONT HEAD DETAIL
1" = 1'-0"

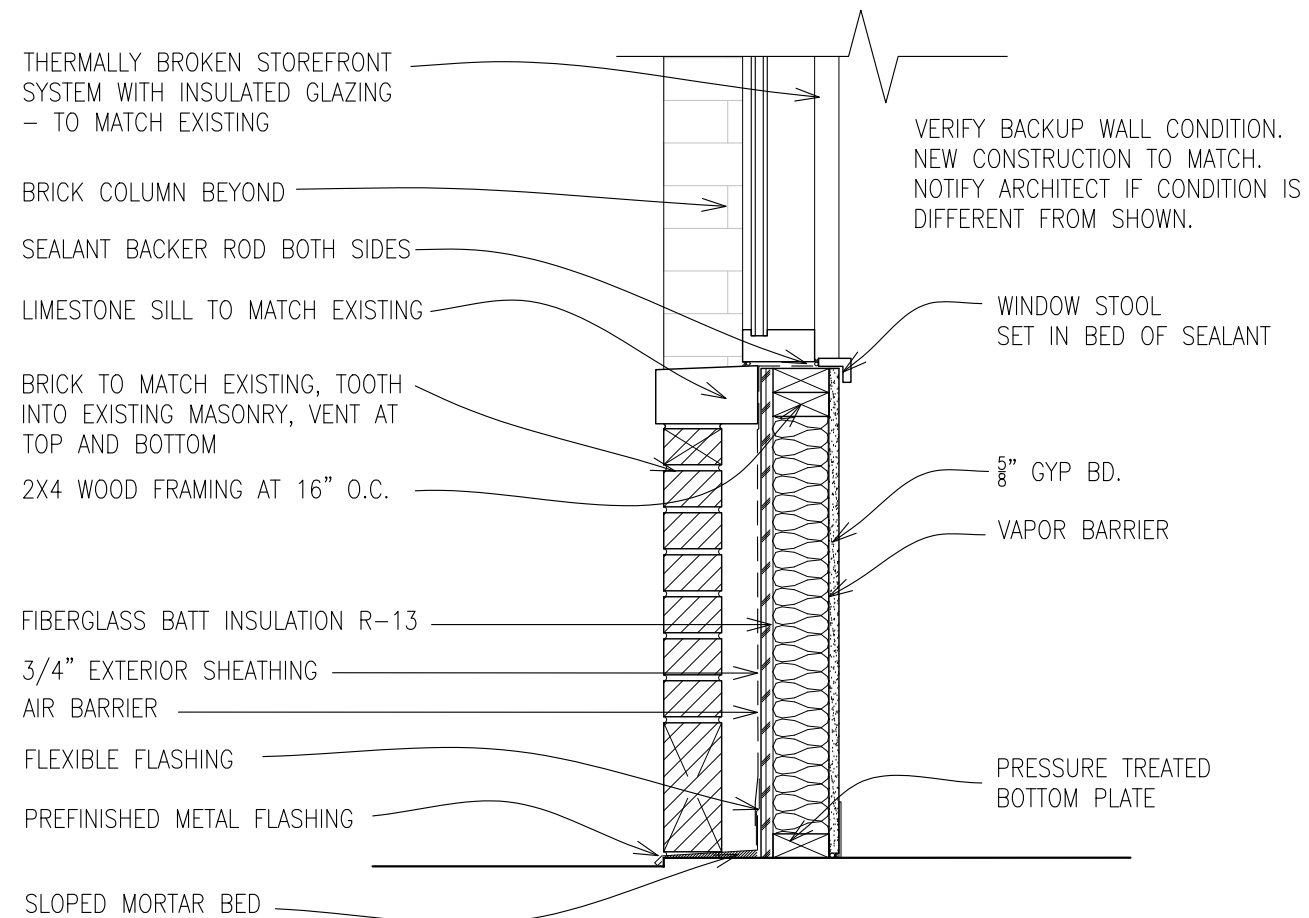

3 KNEE WALL DETAIL
1" = 1'-0"

EXTERIOR DETAILS - A3-01



1 EXISTING PHOTO
NTS

EXISTING PHOTOS A0-01



2 EXISTING PHOTO
NTS

EXISTING PHOTOS A0-01