



LIVING WITH HISTORY

Certificate of Appropriateness

Milwaukee Historic Preservation Commission/200 E. Wells Street/Milwaukee, WI 53202/phone 414-286-5712/fax 414-286-3004

Property 827-829 E. BRADY ST. Brady Street Historic District
Description of work Four condenser units will be installed on the rear of the flat roof-top. These units won't be visible from the street.
Date issued 6/1/2016 PTS ID 111207 COA

In accordance with the provisions of Section 320-21 (11) and (12) of the Milwaukee Code of Ordinances, the Milwaukee Historic Preservation Commission has issued a certificate of appropriateness for the work listed above. The work was found to be consistent with preservation guidelines. The following conditions apply to this certificate of appropriateness:

All work to be carried out per application.

All work must be done in a craftsman-like manner, and must be completed within one year of the date this certificate was issued. Staff must approve any changes or additions to this certificate before work begins. Work that is not completed in accordance with this certificate may be subject to correction orders or citations. If you require technical assistance, please contact Carlen Hatala of the Historic Preservation staff as follows: Phone: (414) 286-5722 Fax: (414) 286-3004 E-mail: carlen.hatala@milwaukee.gov.

If permits are required, you are responsible for obtaining them from the Milwaukee Development Center. If you have questions about permit requirements, please consult the Development Center's web site, www.milwaukee.gov/build, or call (414) 286-8210.

City of Milwaukee Historic Preservation Staff

Copies to: Development Center, Ald. Nik Kovac, Contractor, Inspector Peter Schwartz (286-2537)

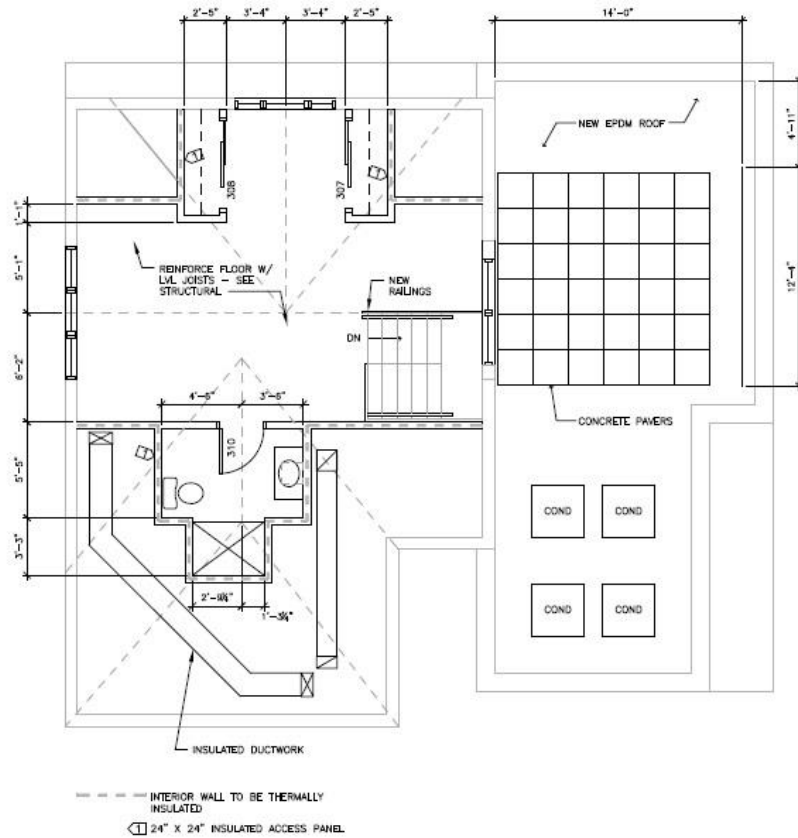

ATTIC FLOOR PLAN

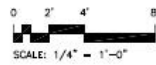

333 East Erie Street
 Milwaukee, Wisconsin 53202-1000
 Telephone 414.279.4200 Fax 414.279.2700

RENOVATION OF 827-29
 EAST BRADY STREET
 MILWAUKEE, WISCONSIN

PEPERONI-CANNOLI LLC
 1019 EAST KEWAUNEE ST.
 MILWAUKEE, WISCONSIN

NO	DESCRIPTION	DATE
	MISC. REV.	11/29/15
1	MISC. REV.	4/11/16

HGA NO. 3834-001-00

ATTIC
 FLOOR PLAN

DATE 11/5/15

CONSTRUCTION DOC.

A2.3



PRODUCT SPECIFICATIONS

DIMENSIONS

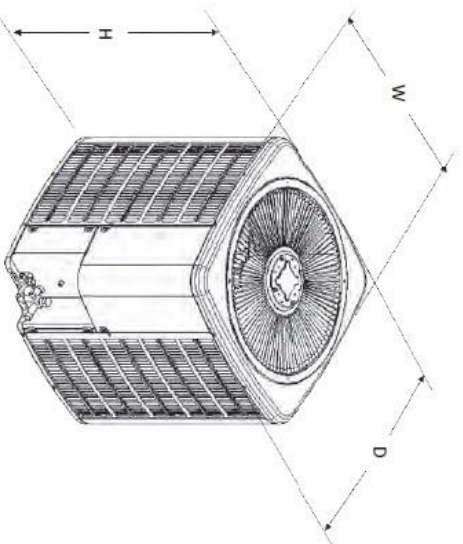

MODEL	DIMENSIONS		
	W"	D"	H"
VSX130181D*	23	23	23 1/4
VSX130181E*	23	23	25 1/4
VSX130241D*	23	23	25 1/4
VSX130301D*	23	23	25 1/4
VSX130361D*	23	23	30 1/4
VSX130421B*	29	29	36 1/4
VSX130481B*	29	29	36 1/4
VSX130601B*	29	29	40