

DECK NOTES:

- DECKING SURFACE TO BE (1) STEP BELOW FIRST FLOOR LINE OF HOUSE. DECKING SURFACE TO BE LESS THAN 36" ABOVE SURROUNDING GRADES.
- TREATED FRAMING
- TREATED DECKING 1" x 3/4"
- SKIRTING - 1x6 vertical boards to grade w/ 1/4" GAPS
- RAILINGS - TREATED TOP & BOTTOM RAILS w/ ROUND ALUMINUM PICKETS, 4x4 posts, see below
- STEPS - TREATED RISERS & TREADS
- FOOTINGS - 18" DIAMETER CONCRETE POST FOOTINGS TO 48" DEPTH.

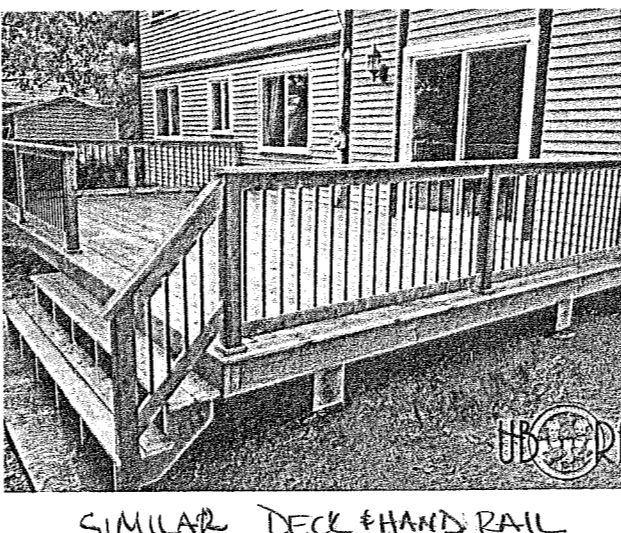

NOTICE: These drawings and designs are the exclusive property of The Secret Garden. Any use or reproduction of this work without the written consent of The Secret Garden is strictly prohibited. The Designer shall not be liable for any damages, including consequential damages, arising from any errors or omissions in the drawings or designs. The Designer shall not be responsible for any conditions that may exist at the time of construction. The Designer shall not be responsible for any conditions that may exist at the time of construction. The Designer shall not be responsible for any conditions that may exist at the time of construction.

OWNER RELEASE: I have reviewed the drawings for design intent and hereby certify that they conform in all respects to my design criteria and are approved.

SIGNATURE: _____ DATE: _____

These drawings may have been reproduced at a size different than originally drawn. Owner and Designer assume no responsibility for use of incorrect scale.

JAY MICHELLE BERMAN
2542 N. TERRE AVENUE
MILWAUKEE, WI 53201

Date: 12.16.21
Drawn By: MJB/RL
Scale: 1" = 1/4"
Revisions: 03.09.22
03.17.22

The Secret Garden
GARDEN DESIGN / CONSTRUCTION AND MAINTENANCE
7501 W. Donges Bay Road • Mequon, Wisconsin 53092
(414) 351-5370 office • (414) 531-2920 mobile
www.TheSecretGardenLandscape.com

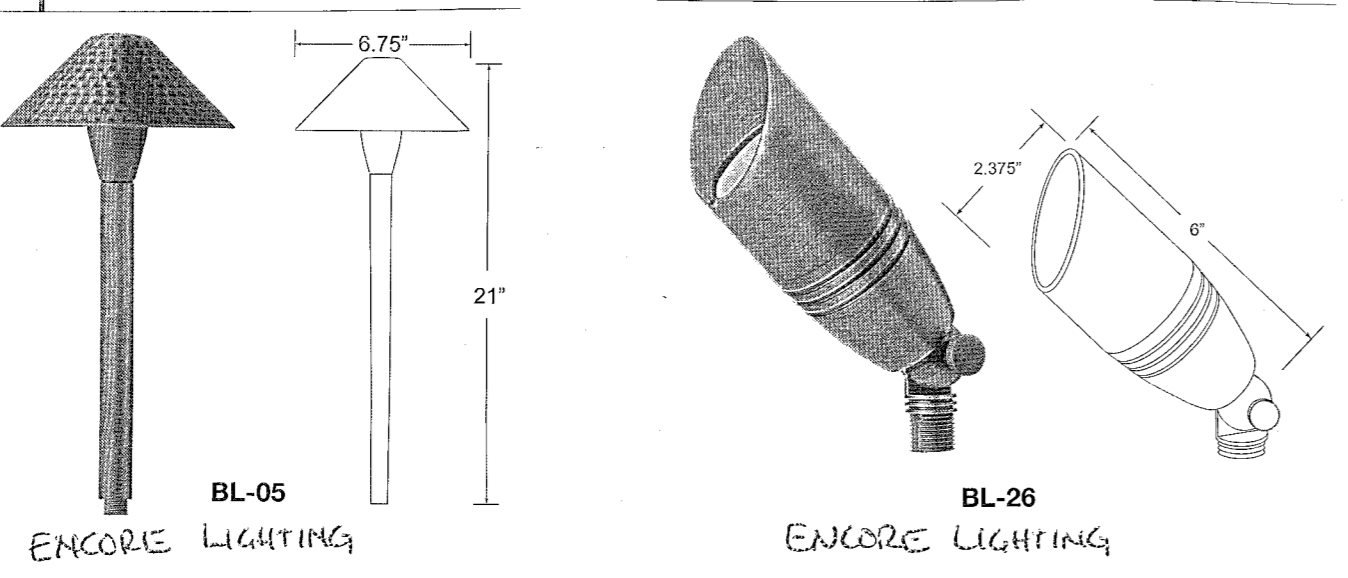

LIGHTING LEGEND	
▲	UP LIGHT (5)
●	PATH LIGHT (4)
■	STEP LIGHT (5)

