

Washington Heights Public Art Project Proposal

Vliet Street Commons

(a working title)

Jill Sebastian, Artist

Introduction

Description of the Current Site

- A triangle of grass nestled among Wick baseball fields/tennis courts.
- A flat green overlooked **no-place** on busy 50th & Vliet Streets.
- Has strong light conditions at night, exposed to elements, is treeless.
- Is dominated by bleachers, field house
- Amenities are available from the business district across the street.

Artist's Perception

- Washington Heights strong sense of community can be given symbolic expression through a work of public art.
- A place can be made where people want to spend time in ways that promote neighborhood.
- The eccentric qualities such as ballpark lighting can be used to dramatic advantage.

Concept

Uses of the space

- Provide a gathering place for block club and neighborhood meetings through the focal point of an enormous community table.
- Shape the overall environment to promote public events such as music, group events or plays.
- On a day to day basis, provide a variety of options for individuals to sit and relax, meet friends, picnic.
- Create a park or commons with aesthetic interest from both within the area and as seen by passing traffic on Vliet Street.
- Give a unique sense of place or identity to the neighborhood.

Description of the design

- **The Arbor:** The overall shape of the current grassy triangle will be utilized by a sweeping arc of raised concrete which can be used as a low stage. This arc will be bounded by a screen of sculptural shapes and plant growth designed to cast dramatic shadows onto the concrete by both sunlight and lights at night. Further the arbor will serve as a privacy screen to separate the commons from the ballpark activity. Electric outlets will be run through the arbor to provide connections for lighting and sound equipment.
- **The Community Table:** The focal point of the design, the table is centered at the apex of the arc, closer to the street. The table is a sculptural interpretation of all sorts of ways for people to sit together. Thus it may become the symbol of this neighborhood coming together to relate to one another in special ways.
- **Intimate Places:** In addition to unique choices at the table itself several other attendant benches will provide opportunities for more private seating and reflection.
- **Reading Garden:** Beyond the arc, at the far south point of the triangle a reading garden comprised of boxwood hedges, bench, desk and birdbath is planned. A walkway extends from the community table through an arch in the arbor that frames a special view of the garden with a bench around a flowering cherry tree.
- **Community Garden:** At the northwest corner, near Vliet, is an opportunity to create a community planned and maintained garden.
- **Landscaping:** Quite a number of additional trees are being proposed to make the space quieter, more comfortable yet not impinge on the open grassy area needed for seating should events occur on the raised platform of the arbor. The boxwood hedges of the Reading Garden and the foliage for the arbor

Naming the Park

- **Vliet Street Commons** is the artist's working title. Either the committee and artist can continue to work on ideas to name this new place or it could be opened to community for suggestions.

Other considerations

- **Moving the driveway, adding a sculptural gate, signage:**
Though not considered in this initial proposal due to cost, the feasibility of reshaping the driveway should be considered. Likewise the current yellow gate and signage could be effectively redesigned to support the grace and flow of the whole.
- **Field House:** At a reasonable cost, the field house could have some superficial design changes/additions made.
- **Parking:** Several stalls of street parking on both sides of Vliet should be eliminated to strengthen the connection between the neighborhood and the park through clear visibility and appreciation.

Maintenance

- The design of the project takes into account the types of materials and responsibilities currently in evidence in the surroundings.
- Several avenues for ongoing care may be explored:
 - * Placing the park under the umbrella of maintenance for Wick Fields
 - * Making it the responsibility of the Vliet Street Business Association.
 - * Becoming the cooperative effort of the neighborhood groups.
- Upon completion, the artist will provide a maintenance plan.

PHASE I: The Community Table / Trees

BUDGET

including design fee for the sculptural table.

TABLE TIMETABLE

- February - April 2001
Fabrication of benches and chairs
- May 15, 2001
Begin excavation and frost free foundation work, build forms.
- June 2001
Pour pad, table top, finish concrete. Install benches/chairs.
- ~~July 4, 2001~~ Dedication. *TO BE DETERMINED*

TREES

- An additional cost or possible donation (through the city?).
- Can be planted in advance of July 4th or be a community planting at the dedication.

PHASE II: Arbor, Reading Garden and additional Landscaping.

BUDGET

- To be determined, design fee already covered.

TIMETABLE

- To be determined.
If run concurrent with the Table, fabrication of the Arbor parts could begin earlier in January. The excavation and concrete work would be coordinated with the Table. Completion by September 1, 2001.

OTHER

- The building of the arbor will be much like installing a fence. It could become a community project like an old fashioned weekend barn raising.
- The local garden club could work with the artist in designing and planting the Community Garden.

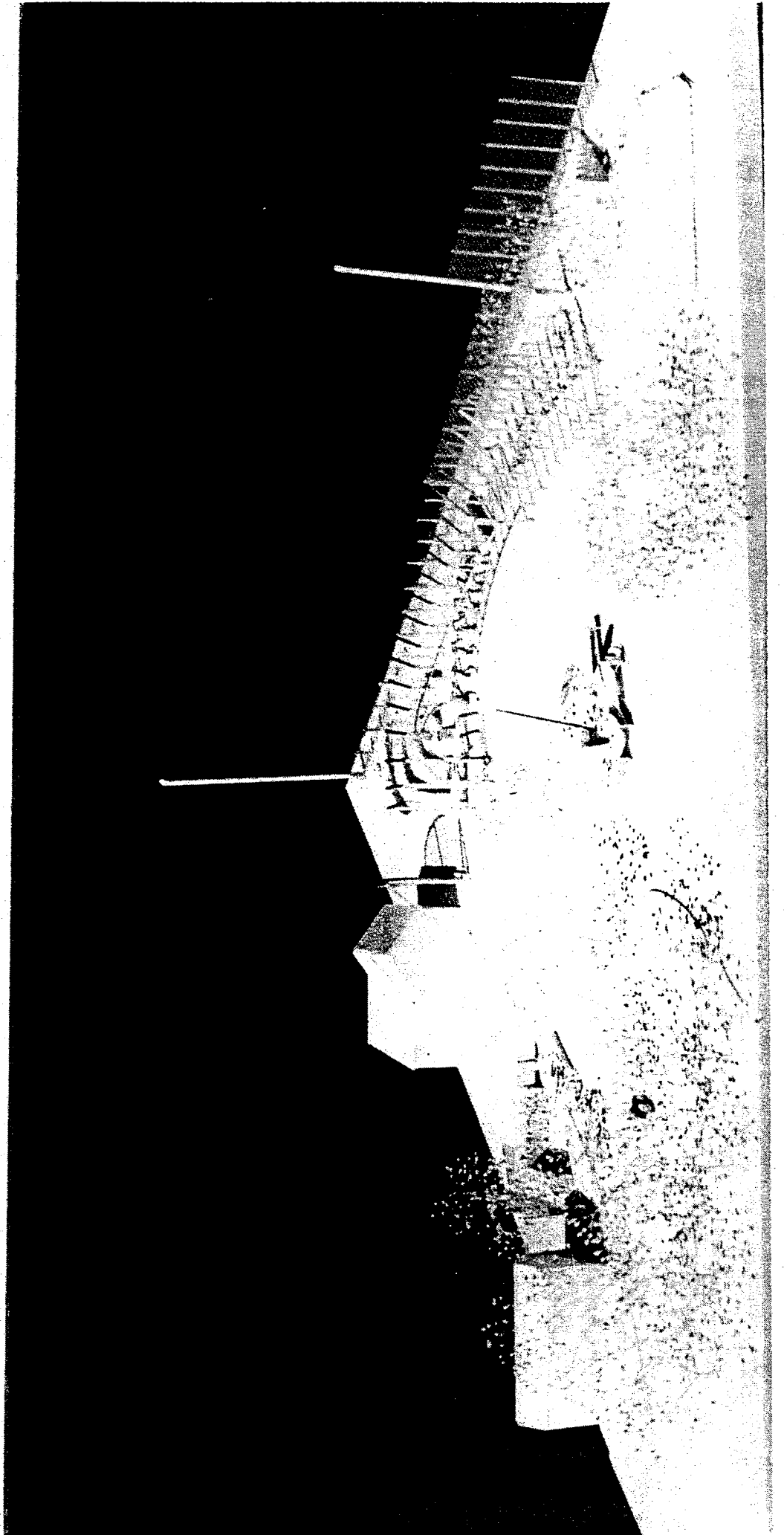

Jill Sebastian

4801 North Lincoln Street
Milwaukee, Wisconsin 53222
414-372-0074
414-372-4174
e-mail: jsebastian@jillsebastian.com

PROJECT: Washington Heights Neighborhood
DESCRIPTIONS: Park
DATE: April 1, 2009
REVISION: January 2, 2001
PAGE: 1
SCALE: 1 inch = 2 feet

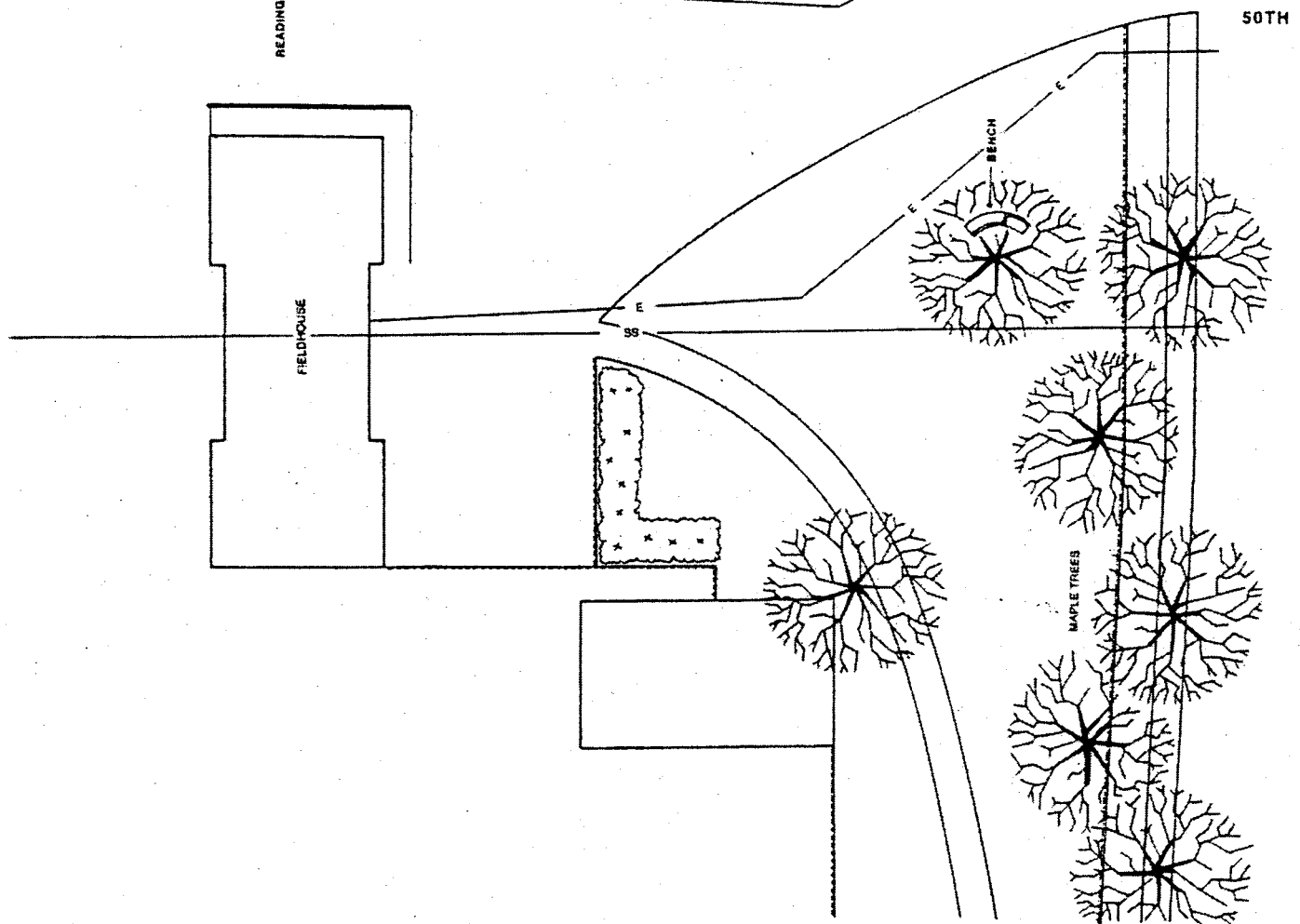
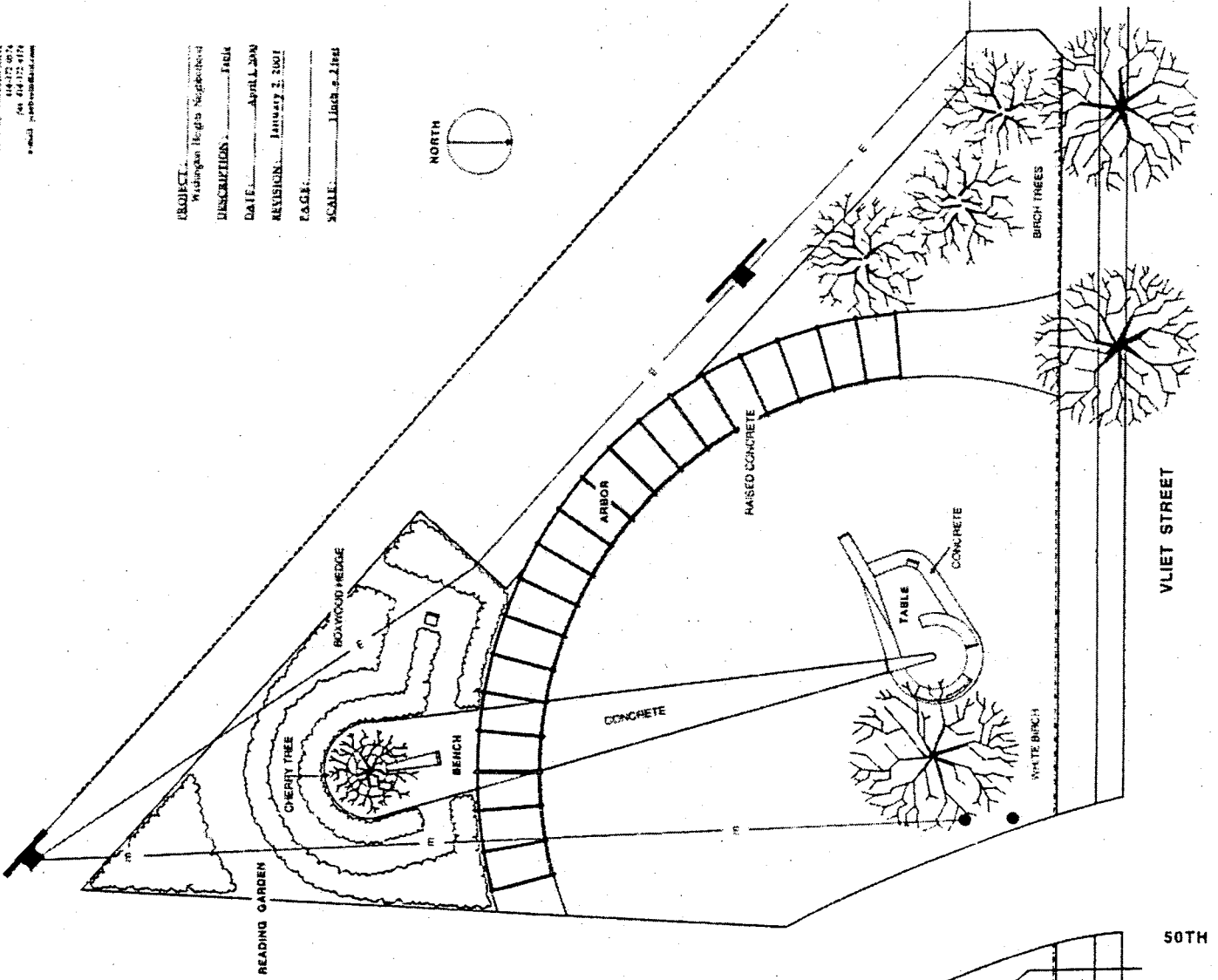

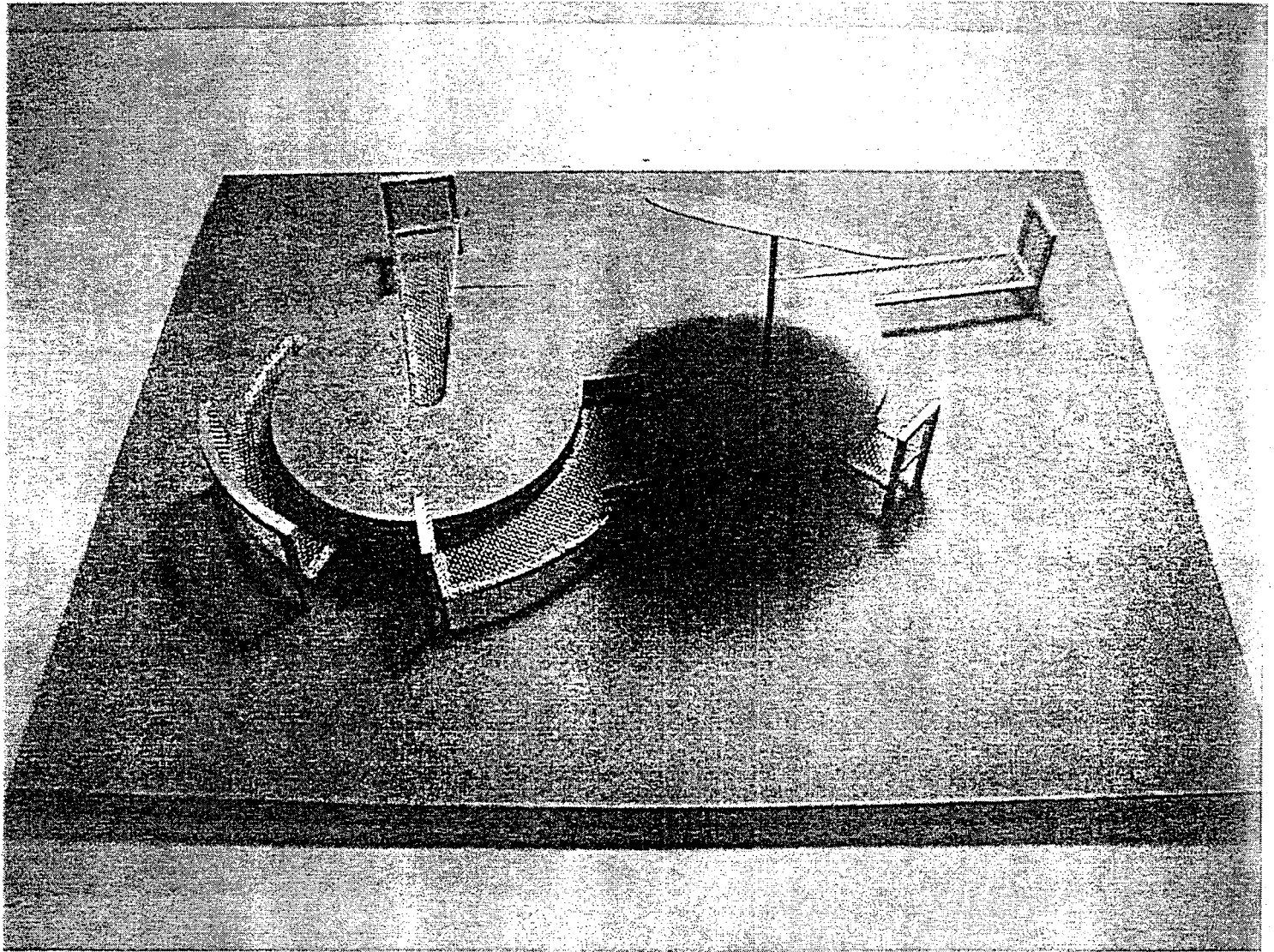

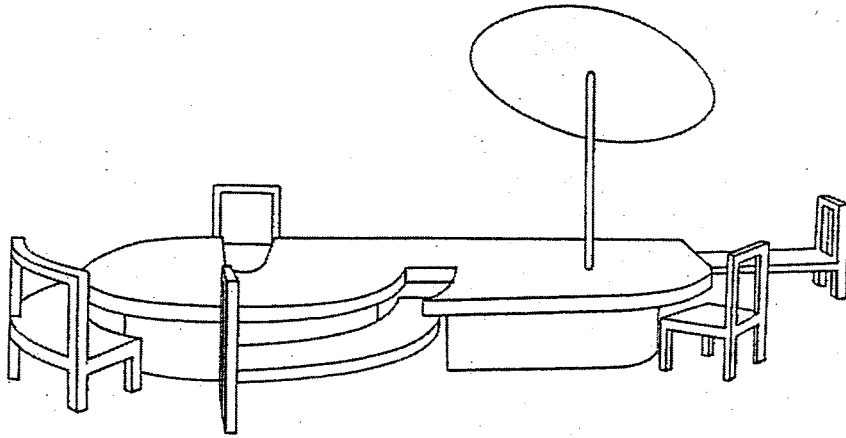

The Community Table view 1

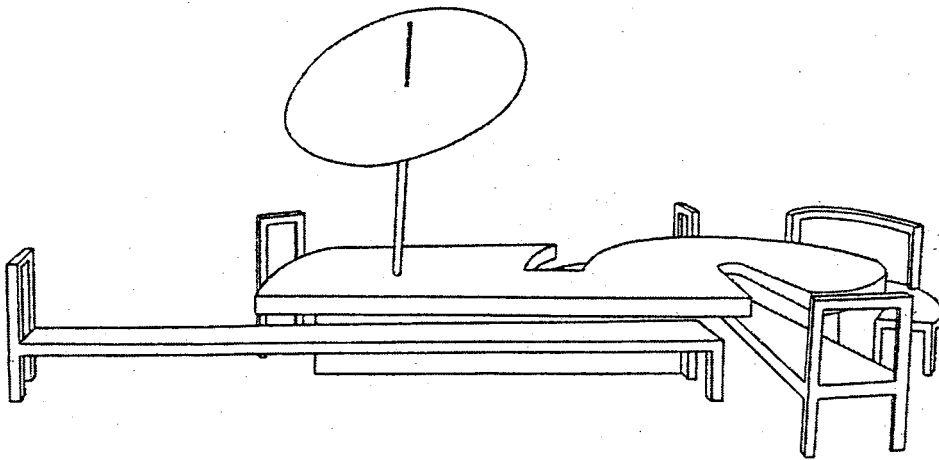

The Community Table view 2

Jill Sebastian

2807 North Farney Street
Milwaukee, Wisconsin 53212
414-724-9374
for 414-324-9174
e-mail jsebastian@aol.com

PROJECT: Washington Heights Neighborhood
DESCRIPTION: Table
DATE: April 2004
REVISION:
PAGE:
SCALE: 1/4" = 1'-0"

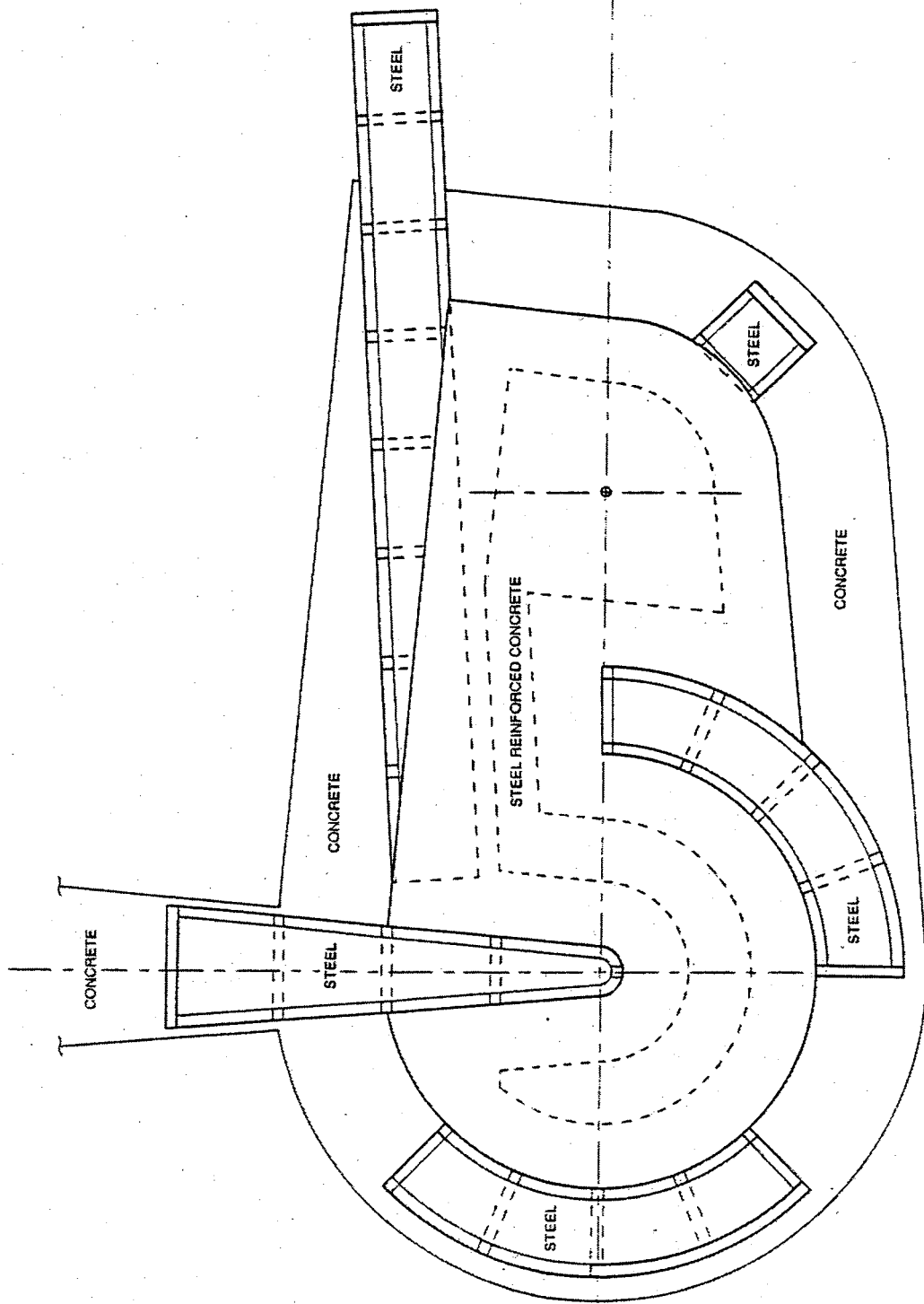

STEEL-REINFORCED CONCRETE

TABLE BASE
TOP VIEW

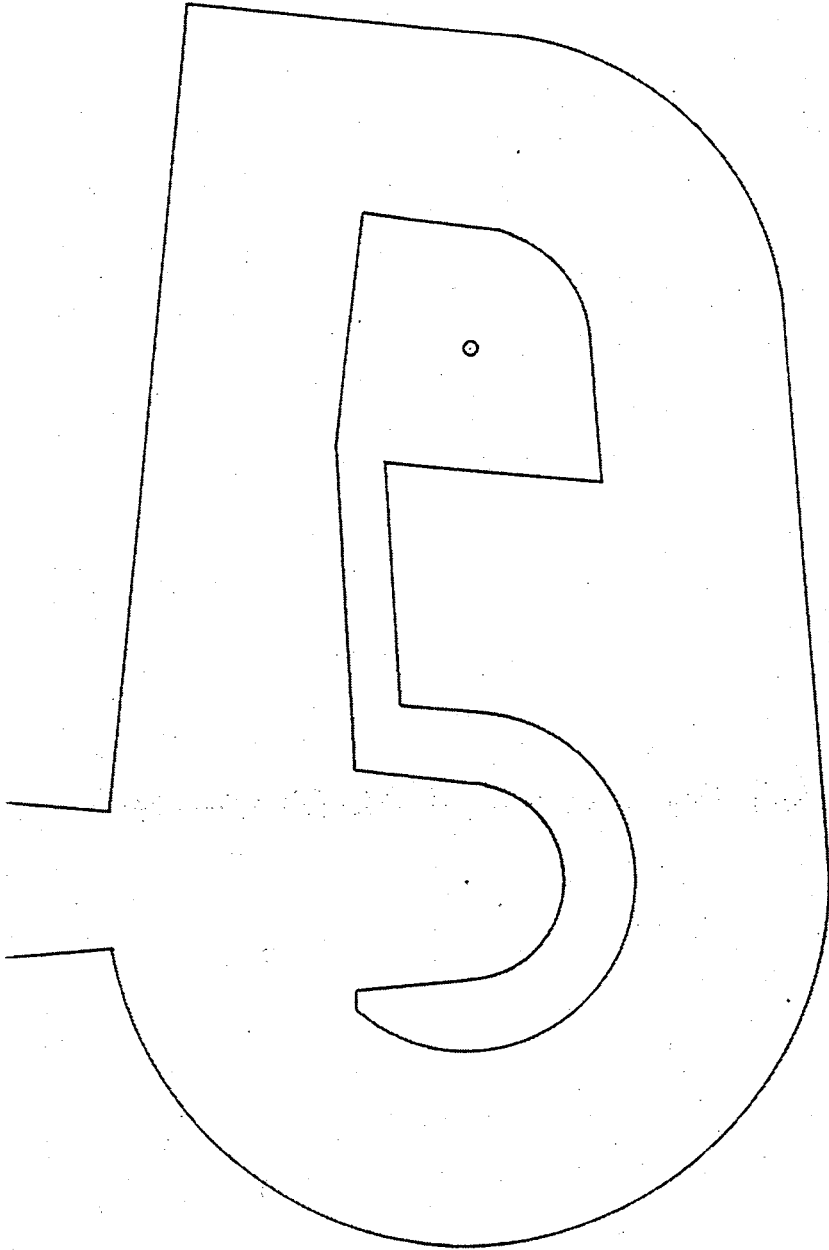
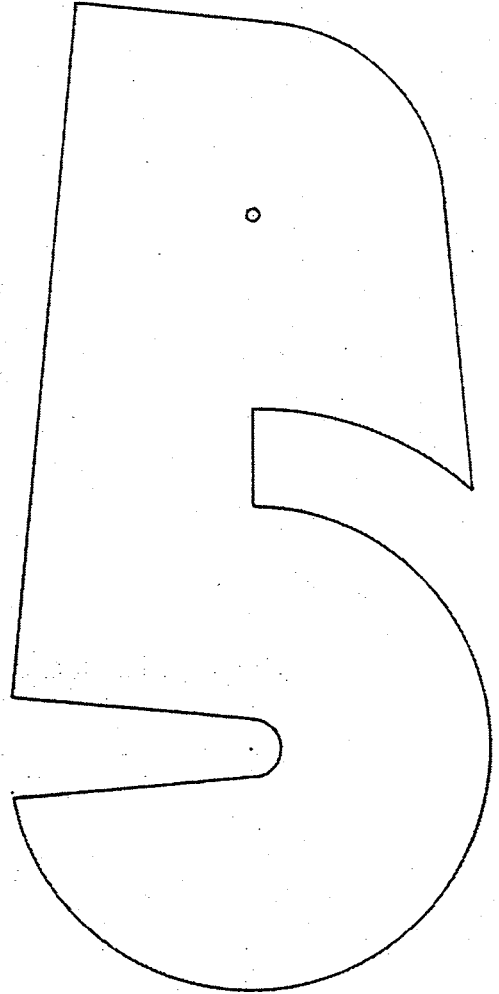

TABLE TOP



Jill Sebastian

2407 North Frahey Street
Alfredacker, Wisconsin 53112
414-372-9574
fax 414-372-4174
e-mail jsebastian@aol.com

PROJECT: _____
Washington Heights Neighborhood
DESCRIPTION: _____ Table
DATE: _____ April 1, 2002
REVISION: _____
PAGE: _____
SCALE: _____ 1 inch = 2 feet

Jill Sebastian

2807 North Training Street
Milwaukee, Wisconsin 53212
414-372-6574
fax 414-372-8174
e-mail jsebastian@aol.com

PROJECT: Washington Heights Neighborhood
DESCRIPTION: TABLE FOUNDATION
DATE: April 1, 2000
REVISION:
PAGE:
SCALE: 1/4" = 2'-0"

STEEL-REINFORCED CONCRETE

NORTH

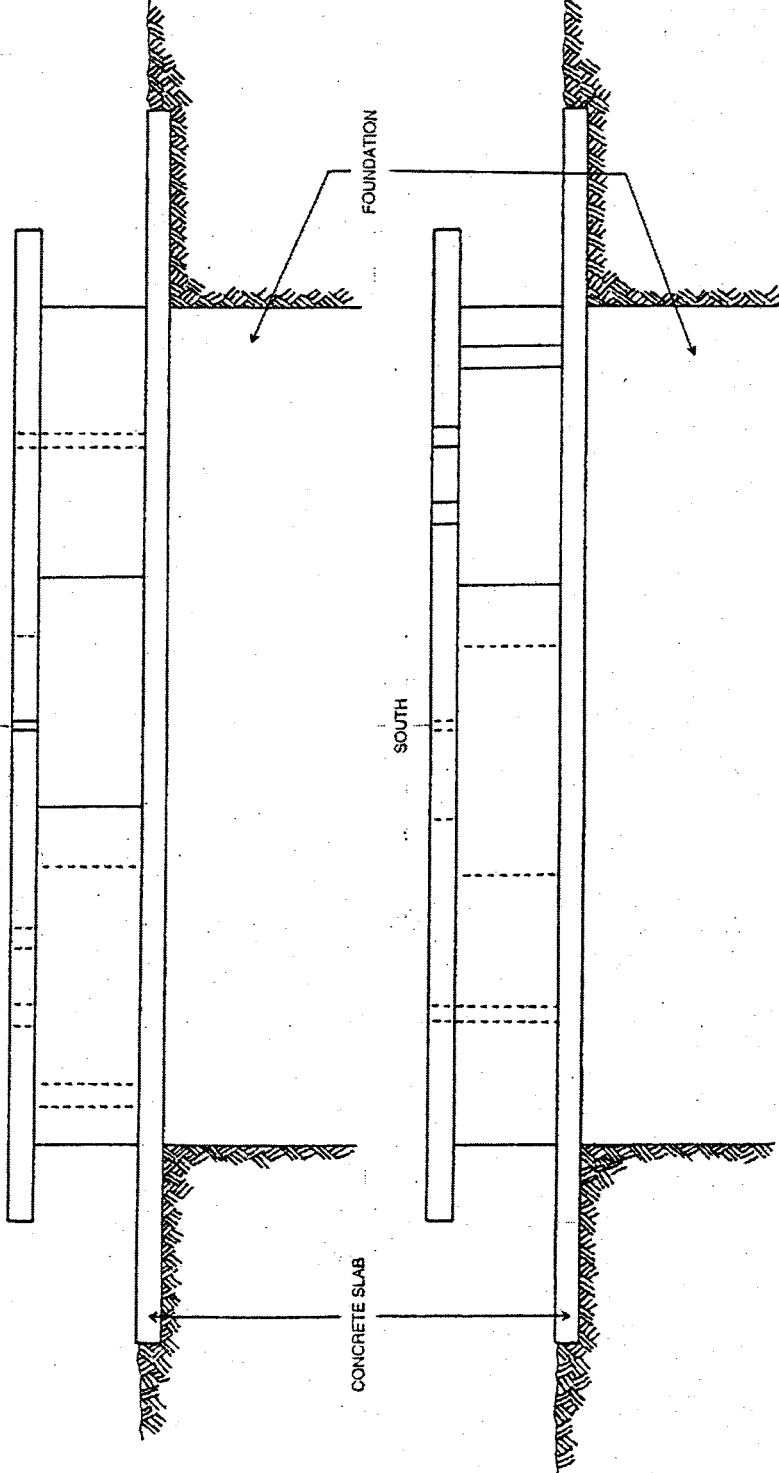

EAST

WEST

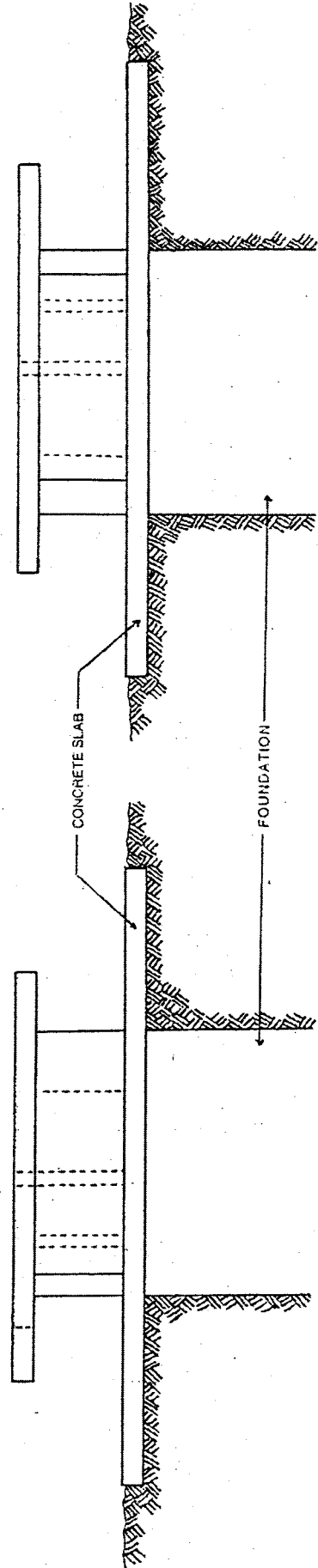

Jill Sebastian

2807 North Training Street
Milwaukee, Wisconsin 53212
414-372-8574
fax 414-372-4174
e-mail jsebastian@aol.com

PROJECT: _____

Washington Heights Neighborhood

DESCRIPTION: _____ Table

DATE: _____ April 1, 2000

REVISION: _____

PAGE: _____

SCALE: _____ 1 inch = 2 feet

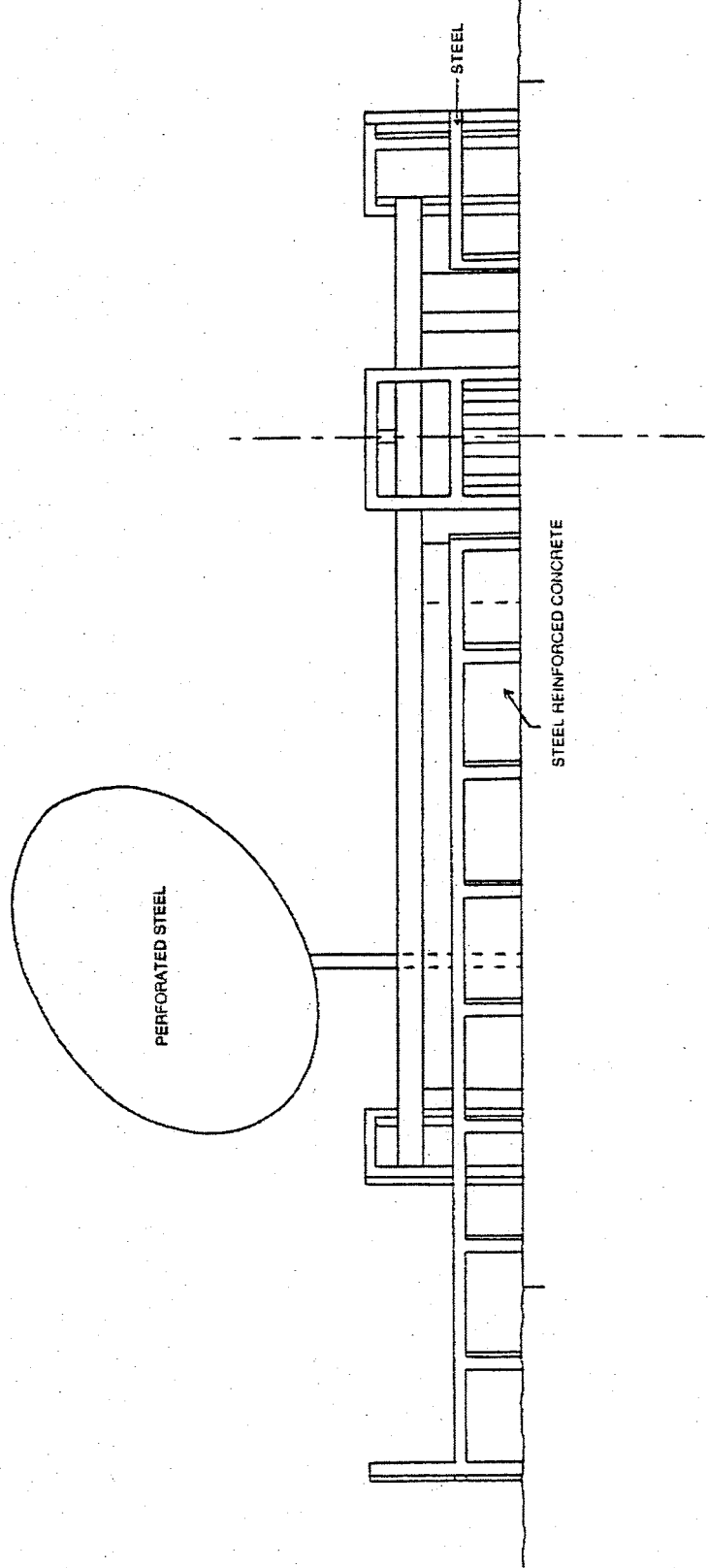
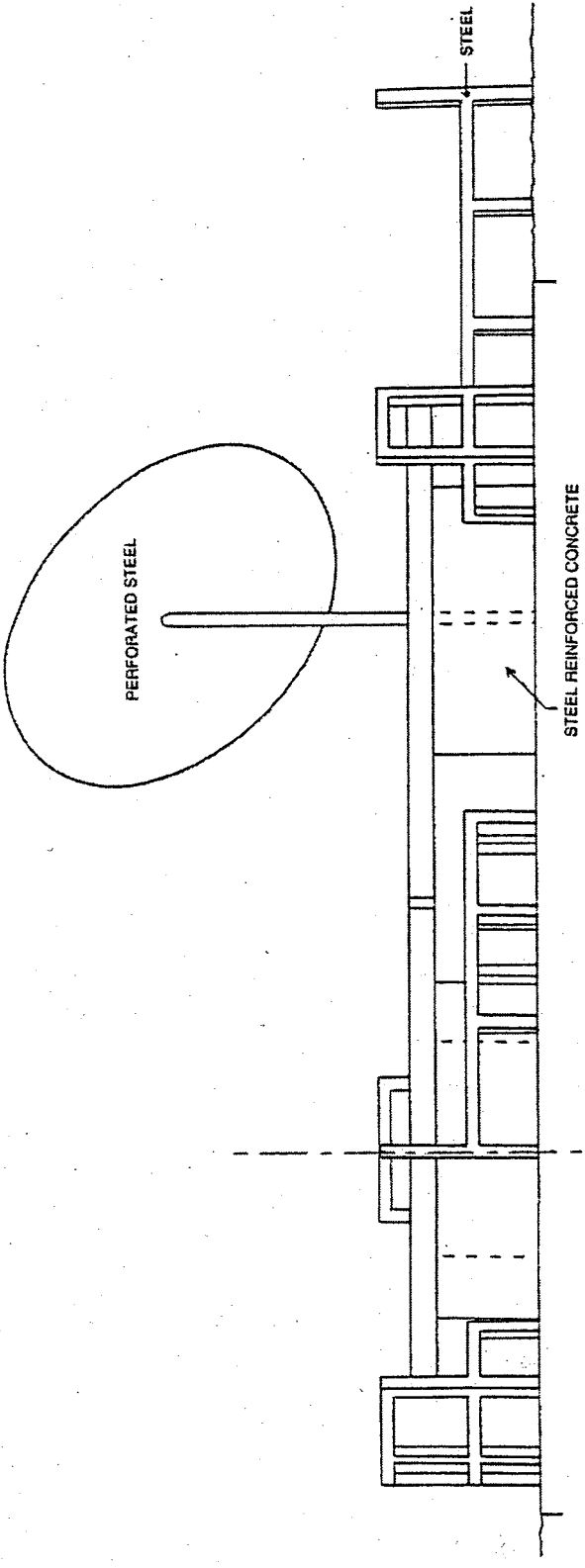

Jill Sebastian

2807 North Frohney Street
Milwaukee, Wisconsin 53212
414-372-4574
Fax 414-372-4174
e-mail jsebastian@aol.com

PROJECT: Washington Heights Neighborhood
DESCRIPTION: Table
DATE: April 1, 2000
REVISION:
PAGE:
SCALE: 1 Inch = 2 feet

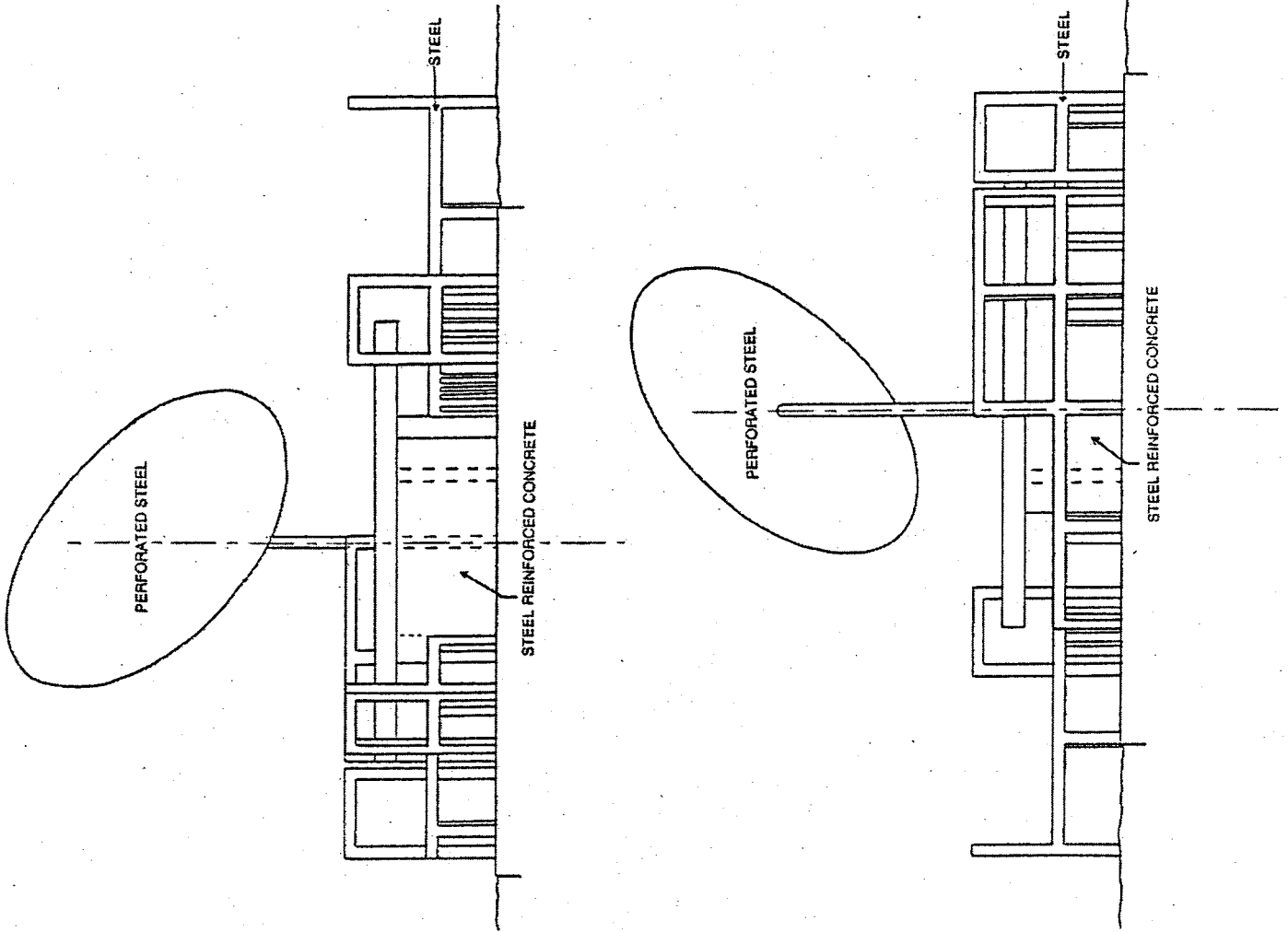

Jill Sebastian

2807 North Erving Street
Milwaukee, Wisconsin 53212
414-372-0573
Fax 414-372-4174
e-mail jsebastian@aol.com

PROJECT: Washington Heights Neighborhood

DESCRIPTION: Tree Bench &

DATE: April 1, 2000

REVISION:

PAGE:

SCALE: 1 inch = 2 feet

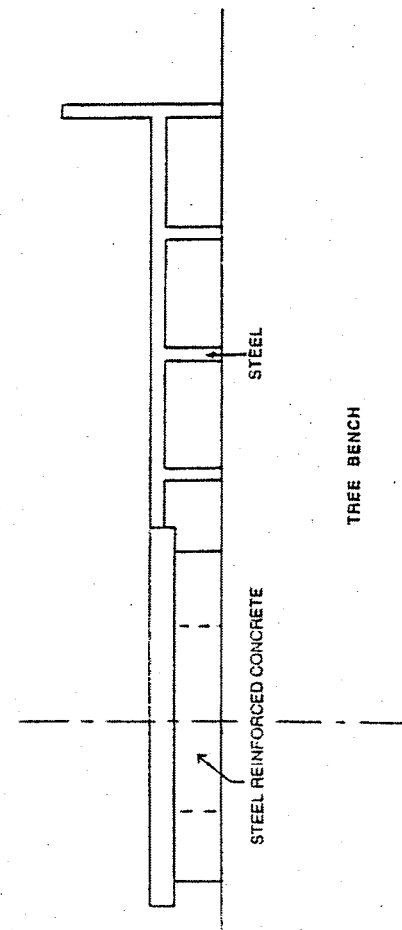
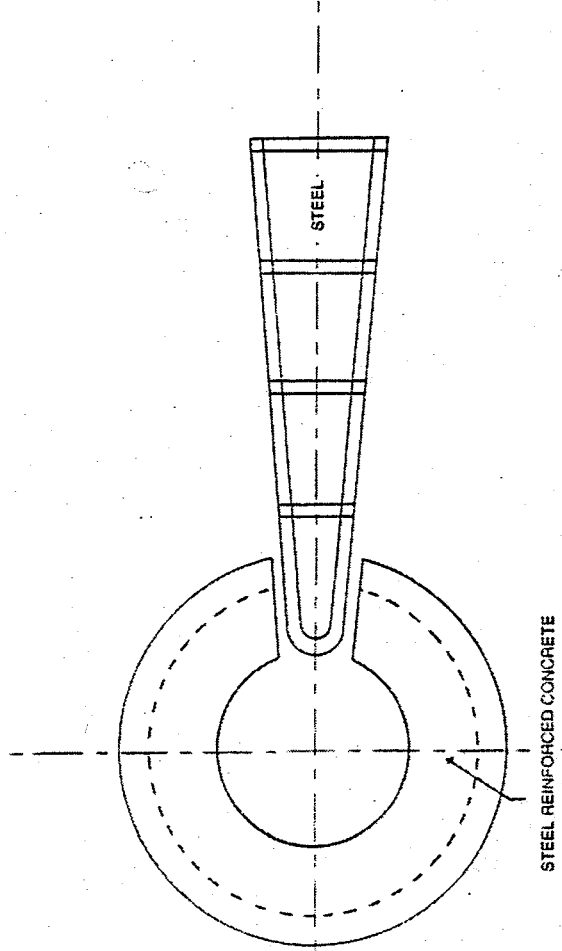
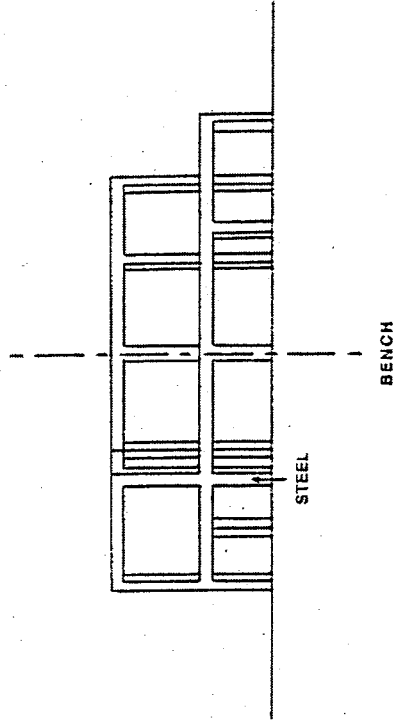
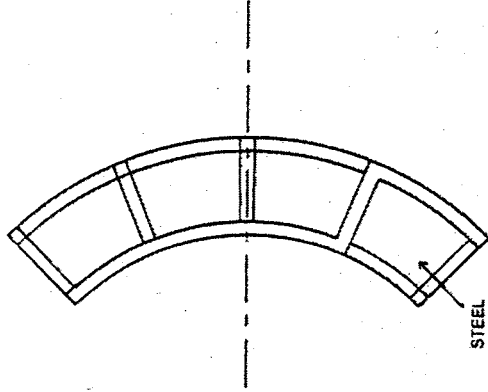

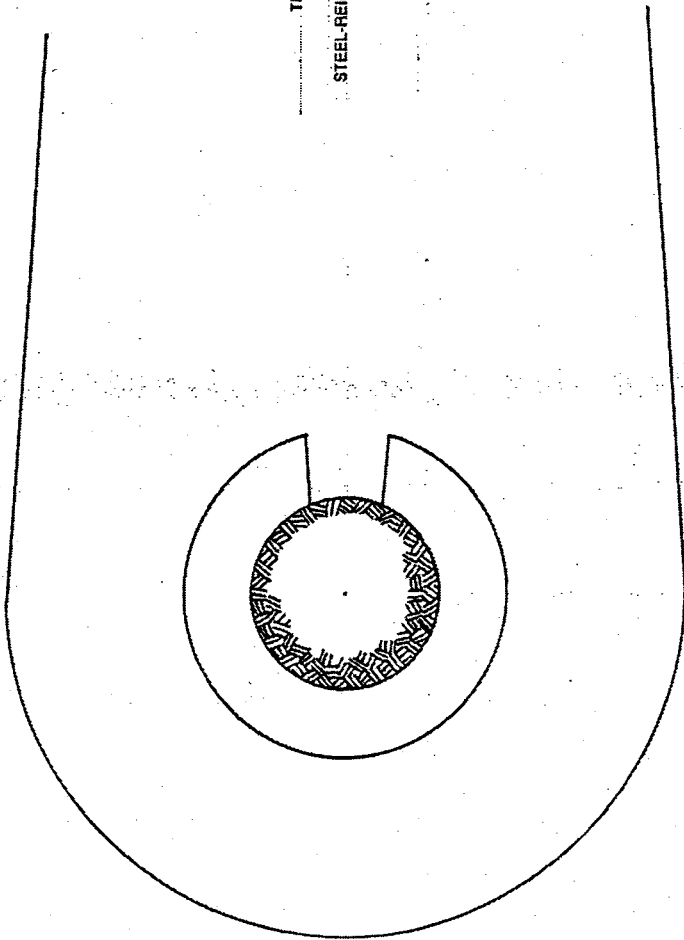

TREE BENCH

STEEL-REINFORCED CONCRETE

TOP VIEW

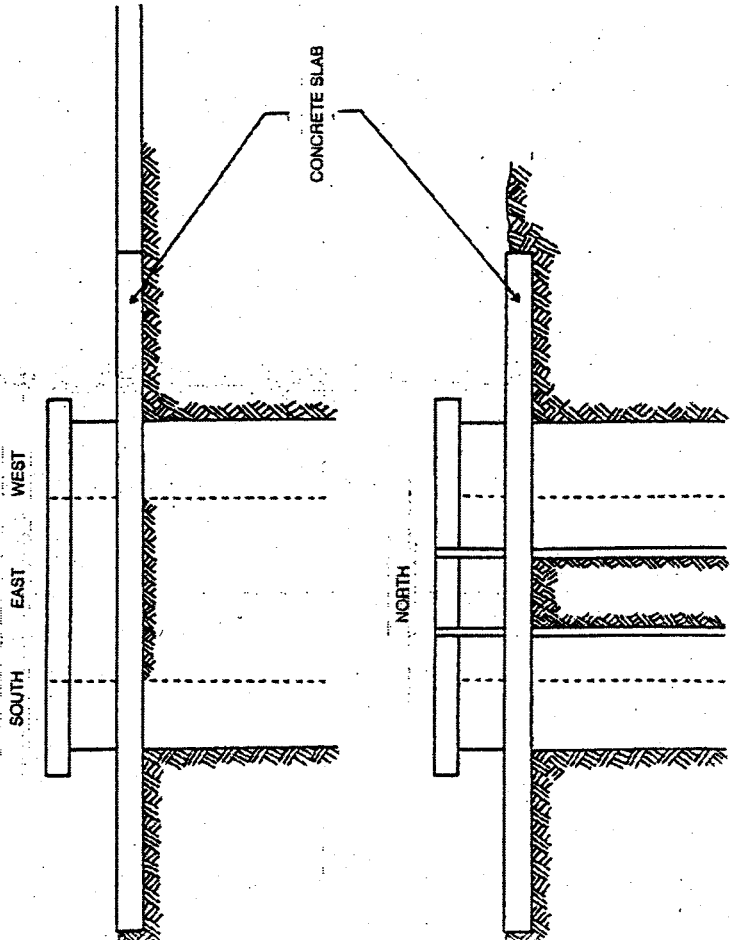

TREE BENCH

SOUTH

EAST

WEST

CONCRETE SLAB

NORTH

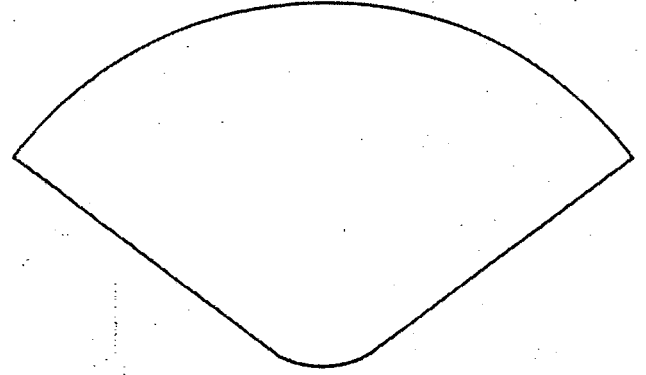
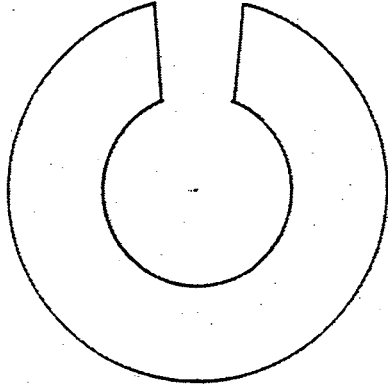

TOP VIEW

Jill Sebastian
 2407 North Prairie Street
 Milwaukee, Wisconsin 53212
 414-372-4374
 414-372-4374
 e-mail: jsebastian@aol.com

PROJECT: Washington Heights Neighborhood
 DESCRIPTION: Table
 DATE: April 1, 2003
 REVISION:
 PAGE:
 SCALE: 1 inch = 2 feet